

# catalogo generale eco**materiali**



CASALGRANDE  
PADANA  
Pave your way

100%  
MADE  
IN ITALY

Casalgrande Padana si riserva il diritto di apportare al presente catalogo variazioni e/o correzioni sulla base dell'evoluzione tecnologica e della ricerca della ottimizzazione del prodotto. I colori e l'estetica dei prodotti sono quanto più possibile vicini a quelli reali, nei limiti dei processi di stampa.

Casalgrande Padana reserves the right to make changes and/or corrections to this catalogue based on the technological developments and product optimisation. The colour and appearance of the products as shown are as close as possible to the real thing, inside the limitations of the printing process.

Casalgrande Padana se réserve le droit d'apporter des modifications et/ou des corrections au présent catalogue, en fonction de l'évolution technologique et de la recherche en matière d'optimisation du produit. Les couleurs et l'apparence des produits sont aussi fidèles à la réalité que possible, dans les limites des processus d'impression.

Casalgrande Padana behält sich das Recht vor, auf Grundlage der technischen Entwicklung und der Erforschung der Produktoptimierung Änderungen und/ oder Korrekturen an diesem Katalog vorzunehmen. Die Farben und das Aussehen der Produkte entsprechen den tatsächlichen Produkten, soweit dies im Rahmen der Druckprozesse möglich ist.

Questo catalogo è stampato su carta certificata FSC®.  
This catalog is printed on FSC® certified paper.



# catalogo generale eco**materiali**



CASALGRANDE  
PADANA  
Pave your way

# INDICE INDEX

<b>INDICE PER EFFETTO</b> INDEX BY <b>EFFECT</b> <b>INDEX PAR EFFET</b> INDEX DURCH WIRKUNG	<b>03</b>
<b>INDICE PER LINEA</b> INDEX BY LINE <b>INDEX PAR LIGNE</b> INDEX FÜR ZEILE	<b>04</b>
<b>INDICE PER SERIE</b> INDEX BY SERIES <b>INDEX PAR SÉRIE</b> INDEX NACH SERIE	<b>05</b>
<b>INDICE PER FORMATO</b> INDEX BY FORMAT <b>PAR FORMAT</b> NACH FORMAT	<b>06</b>
<b>INDICE PER ARTICOLO</b> INDEX BY ARTICLE <b>INDEX PAR ARTICLE</b> INDEX NACH ARTIKEL	<b>08</b>
<hr/>	
<b>VALORI E SOSTENIBILITA'</b> VALUES AND SUSTAINABILITY	<b>12</b>
VALEURS ET DURABILITE' <b>WERTE UND NACHHALTIGKEIT</b>	
<hr/>	
<b>BIOS CERAMICS</b>	<b>14</b>
<hr/>	
<b>ECOPIETRA</b> ECOSTONE <b>ÉCOPIERRE</b> ÖKOSTEIN	<b>40</b>
<b>ECOMARMO</b> ECOMARBLE <b>ÉCOMARBRE</b> ÖKOMARMOR	<b>146</b>
<b>ECOMETALLO</b> ECOMETAL <b>ÉCOMÉTAL</b> ÖKOMETALL	<b>206</b>
<b>ECOLEGNO</b> ECOWOOD <b>ÉCOBOIS</b> ÖKOHOLZ	<b>226</b>
<b>ECOGRANITO</b> ECOGRANITE <b>ÉCOGRANIT</b> ÖKOGRANIT	<b>276</b>
<b>ECOCOLORE</b> ECOCOLOUR <b>ÉCOCOULEUR</b> ÖKOFARBE	<b>298</b>
<b>ECOCEMENTO</b> ECOCONCRETE <b>ÉCOCIMENT</b> ÖKOZEMENT	<b>344</b>
<b>ECOTECNICO</b> ECOTECHNIQUE <b>ÉCOTECHNIQUE</b> ÖKOTECHNIK	<b>412</b>
<hr/>	
<b>CARATTERISTICHE TECNICHE</b> TECHNICAL FEATURES	<b>434</b>
CARACTERISTIQUES TECHNIQUES <b>TECNISCHE EIGENSCHAFTEN</b>	
<hr/>	
<b>VARIAZIONI CROMATICHE</b> CHROMATIC VARIATIONS	<b>448</b>
VARIATIONS CHROMATIQUES <b>FARBTONABWEICHUNGEN</b>	
<hr/>	
<b>COMPLEMENTI IN ACCIAIO</b> ACCESSORIES IN STEEL AND ALUMINIUM	<b>449</b>
COMPLÉMENTS EN ACIER ET EN ALUMINIUM <b>ZUSATZELEMENTE AUS STAHL UND ALUMINIUM</b>	
<hr/>	
<b>VOCI DI CAPITOLATO</b> SPECIFICATIONS	<b>450</b>
CAHIER DES CHARGES <b>AUSSCHREIBUNGSTEXTE</b>	
<hr/>	
<b>POSA E MANUTENZIONE</b> INSTALLATION AND MAINTENANCE	<b>452</b>
POSE ET ENTRETIEN <b>VERLEGUNG UND PFLEGE</b>	
<hr/>	

# INDICE PER EFFETTO INDEX BY EFFECT INDEX PAR EFFET INDEX DURCH WIRKUNG

<b>ECO<b>bios</b></b>	<b>14</b>	<b>ECO<b>marmo</b></b>	<b>146</b>	<b>ECO<b>colore</b></b>	<b>298</b>
Bios ceramics	<b>16</b>	Marmoker	<b>150</b>	Earth	<b>302</b>
Bios self-cleaning	<b>18</b>	Marmosmart	<b>172</b>	Architecture	<b>310</b>
Bios antibacterial	<b>28</b>	Terrazzo	<b>178</b>	Unicolore	<b>322</b>
		Macro	<b>184</b>	Caleidoscopio	<b>328</b>
<b>ECO<b>pietra</b></b>	<b>40</b>	Marte	<b>188</b>	Elementi	<b>334</b>
Pietre di paragone	<b>44</b>	Onici	<b>200</b>	Landscape	<b>338</b>
Amazzonia	<b>54</b>				
Chalon	<b>60</b>	<b>ECO<b>metallo</b></b>	<b>206</b>	<b>ECO<b>cemento</b></b>	<b>344</b>
Boulder	<b>66</b>	Kerinox	<b>210</b>	Manhattan	<b>348</b>
Meteor	<b>72</b>	Metallica	<b>214</b>	R-evolution	<b>354</b>
Mineral chrom	<b>78</b>	Steeltech	<b>220</b>	Beton	<b>360</b>
Pietra Baugé	<b>84</b>			Cemento	<b>368</b>
Pietre di Sardegna	<b>90</b>	<b>ECO<b>legno</b></b>	<b>226</b>	Resina	<b>378</b>
Stonewash	<b>102</b>	Country wood	<b>230</b>	Spazio	<b>384</b>
Terre Toscane	<b>106</b>	Class wood	<b>236</b>	Eco concrete	<b>390</b>
Pietre Etrusche	<b>112</b>	Geowood	<b>240</b>	Opus	<b>394</b>
Basaltina	<b>118</b>	Tavolato	<b>244</b>	Città	<b>404</b>
Kerblock	<b>122</b>	Planks	<b>250</b>	Living	<b>408</b>
Titano	<b>126</b>	Limpha	<b>254</b>		
Ardesia	<b>130</b>	Ulivo	<b>258</b>	<b>ECO<b>tecnico</b></b>	<b>412</b>
Lavagna	<b>134</b>	Newood	<b>264</b>	Technic	<b>416</b>
Patio	<b>138</b>	Metalwood	<b>270</b>	Tactile	<b>426</b>
Agorà	<b>142</b>				
		<b>ECO<b>granito</b></b>	<b>276</b>	<b>ECO<b>utility</b></b>	<b>430</b>
		Granito evo	<b>280</b>		
		Granito 1	<b>284</b>		
		Granito 2	<b>290</b>		
		Granito 3	<b>294</b>		

## INDICE PER LINEA INDEX BY LINE INDEX PAR LIGNE INDEX FÜR ZEILE

<b>GRANITOGRES</b>	Agorà	142
	Architecture	310
	Ardesia	130
	Elementi	334
	Granito evo	280
	Granito 1	284
	Granito 2	290
	Granito 3	294
	Marte	188
	Tactile	426
	Technic	416
	Titano	126
	Unicolore	322

<b>PIETRE NATIVE</b>	Amazzonia	54
	Basaltina	118
	Boulder	66
	Chalon	60
	Kerblock	122
	Lavagna	134
	Meteor	72
	Mineral chrom	78
	Pietra baugé	84
	Pietre di Paragone	44
	Pietre di Sardegna	90
	Pietre Etrusche	112
	Spazio	384
	Terre toscane	106

<b>GRANITOKER</b>	Beton	360
	Cemento	368
	Class wood	236

	Country Wood	230
	Earth	302
	Geowood	240
	Kerinox	210
	Limpha	254
	Macro	184
	Manhattan	348
	Marmoker	150
	Marmosmart	172
	Metallica	214
	Metalwood	270
	Newood	264
	Onici	200
	Opus	394
	Planks	250
	R-evolution	354
	Resina	378
	Steeltech	220
	Stonewash	102
	Tavolato	244
	Ulivo	258

<b>GRESPLUS</b>	Città	404
	Eco concrete	390
	Landscape	338
	Patio	138
	Terrazzo	178

<b>ECOGRES</b>	Caleidoscopio	328
	Living	408

# INDICE PER SERIE INDEX BY SERIES

## INDEX PAR SÉRIE INDEX NACH SERIE

<b>Agorà</b>	Granitogres	<b>142</b>	<b>Marmosmart</b>	Granitoker	<b>172</b>
<b>Amazzonia</b>	Pietre native	<b>54</b>	<b>Marte</b>	Granitogres	<b>188</b>
<b>Architecture</b>	Granitogres	<b>310</b>	<b>Metallica</b>	Granitoker	<b>214</b>
<b>Ardesia</b>	Granitogres	<b>130</b>	<b>Metalwood</b>	Granitoker	<b>270</b>
<b>Basaltina</b>	Pietre native	<b>118</b>	<b>Meteor</b>	Pietre native	<b>72</b>
<b>Beton</b>	Granitoker	<b>360</b>	<b>Mineral chrom</b>	Pietre native	<b>78</b>
<b>Boulder</b>	Pietre native	<b>66</b>	<b>Newood</b>	Granitoker	<b>264</b>
<b>Caleidoscopio</b>	Ecogres	<b>328</b>	<b>Onici</b>	Granitoker	<b>200</b>
<b>Cemento</b>	Granitoker	<b>368</b>	<b>Opus</b>	Granitoker	<b>394</b>
<b>Chalon</b>	Pietre native	<b>60</b>	<b>Patio</b>	Gresplus	<b>138</b>
<b>Città</b>	Gresplus	<b>404</b>	<b>Pietra baugé</b>	Pietre native	<b>84</b>
<b>Class wood</b>	Granitoker	<b>236</b>	<b>Pietre di Paragone</b>	Pietre native	<b>44</b>
<b>Country Wood</b>	Granitoker	<b>230</b>	<b>Pietre di Sardegna</b>	Pietre native	<b>90</b>
<b>Earth</b>	Granitoker	<b>302</b>	<b>Pietre Etrusche</b>	Pietre native	<b>112</b>
<b>Eco concrete</b>	Gresplus	<b>390</b>	<b>Planks</b>	Granitoker	<b>250</b>
<b>Elementi</b>	Granitogres	<b>334</b>	<b>R-evolution</b>	Granitoker	<b>354</b>
<b>Geowood</b>	Granitoker	<b>240</b>	<b>Resina</b>	Granitoker	<b>378</b>
<b>Granito evo</b>	Granitogres	<b>280</b>	<b>Spazio</b>	Pietre Native	<b>384</b>
<b>Granito 1</b>	Granitogres	<b>284</b>	<b>Steeltech</b>	Granitoker	<b>220</b>
<b>Granito 2</b>	Granitogres	<b>290</b>	<b>Stonewash</b>	Granitoker	<b>102</b>
<b>Granito 3</b>	Granitogres	<b>294</b>	<b>Tactile</b>	Granitogres	<b>426</b>
<b>Limpha</b>	Granitoker	<b>254</b>	<b>Tavolato</b>	Granitoker	<b>244</b>
<b>Kerblock</b>	Pietre native	<b>122</b>	<b>Technic</b>	Granitogres	<b>416</b>
<b>Kerinox</b>	Granitoker	<b>210</b>	<b>Terrazzo</b>	Gresplus	<b>178</b>
<b>Landscape</b>	Gresplus	<b>338</b>	<b>Terre Toscane</b>	Pietre native	<b>106</b>
<b>Lavagna</b>	Pietre native	<b>134</b>	<b>Titano</b>	Granitogres	<b>126</b>
<b>Living</b>	Ecogres	<b>408</b>	<b>Ulivo</b>	Granitoker	<b>258</b>
<b>Macro</b>	Granitoker	<b>184</b>	<b>Unicolore</b>	Granitogres	<b>322</b>
<b>Manhattan</b>	Granitoker	<b>348</b>			
<b>Marmoker</b>	Granitoker	<b>150</b>			

# INDICE PER FORMATO INDEX BY SIZE PAR FORMAT NACH FORMAT

## 160x320 cm

Cemento	368
Marmoker	150
Pietre di Paragone	44
Pietre di Sardegna	90

## 120x278 cm

Marmoker	150
Onici	202
Pietre di Sardegna	90

## 120x260 cm

Cemento	368
Pietre di Paragone	44
Pietre di Sardegna	90

## 120x240cm

Cemento	368
Limpha	254
Macro	184
Marmoker	150
Onici	200
Pietre di Paragone	44
Pietre di Sardegna	90

## 30x240 cm

Planks	250
--------	-----

## 20x240 cm

Planks	250
--------	-----

## 120x120 cm

Cemento	368
Macro	184
Marmoker	150
Onici	200
Pietre di Paragone	44
Pietre di Sardegna	90
Terre Toscane	106

## 60x120 cm

Architecture	310
Basaltina	118
Cemento	368
Chalon	60

## → 60x120 cm

Earth	302
Eco concrete	390
Macro	184
Marmoker	150
Marmosmart	172
Marte	188
Metalwood	270
Onici	200
Pietre di Paragone	44
Pietre di Sardegna	90
Pietre Etrusche	112
R-evolution	354
Resina	378
Steeltech	220
Stonewash	102
Terre Toscane	106
Unicolore	322

## 40x120 cm

Country Wood	230
--------------	-----

## 30x120 cm

Earth	302
Planks	250
R-evolution	354
Tavolato	244
Ulivo	258

## 20x120 cm

Class Wood	236
Country Wood	230
Metalwood	270
Newood	264
Planks	250
Stonewash	102
Tavolato	244
Ulivo	258

## cm 15x120 cm

Earth	302
Metalwood	270
Newood	264
Tavolato	244

## 90x270 cm

Marmosmart	172
------------	-----

## 90x180 cm

Marmoker	150
Onici	200
Pietre di Paragone	44
R-evolution	354
Resina	378
Stonewash	102

## 30x180 cm

Stonewash	102
-----------	-----

## 22,5x180 cm

Geowood	240
Stonewash	102

## 90x90 cm

Architecture	310
Kerinox	210
Manhattan	348
Marmoker	150
Marmosmart	172
Onici	200
Pietra Baugé	84
Pietre di Paragone	44
Pietre di Sardegna	90
R-evolution	354
Resina	378
Steeltech	220
Stonewash	102

## 45x90 cm

Amazzonia	54
Architecture	310
Basaltina	118
Boulder	66
Manhattan	348
Marmoker	150
Marmosmart	172
Metalwood	270
Newood	264

## → 45x90 cm

Pietre di Paragone	44
Pietre di Sardegna	90
Pietre Etrusche	112
R-evolution	354
Resina	378
Steeltech	220
Terre Toscane	106

## 30x90 cm

Marmosmart	172
------------	-----

## 22,5x90 cm

Newood	264
--------	-----

## 15x90 cm

Architecture	310
Metalwood	270
Newood	264
Tavolato	244

## 11x90 cm

Newood	290
--------	-----

## 45x45 cm

Amazzonia	54
Chalon	60
Città	404
Eco concrete	390
Granito evo	280
Manhattan	348
Meteor	72
Pietre Etrusche	112

## 75,5x151 cm

Beton	360
Spazio	384
Terre Toscane	106

## 25x151 cm

Country Wood	230
--------------	-----



**75,5x75,5 cm**

Beton	360
Cemento	368
Spazio	384
Terrazzo	178
Terre Toscane	106

**37,5x75,5 cm**

Beton	360
Cemento	368
Spazio	384
Terrazzo	178
Terre Toscane	106

**60x60 cm**

Amazzonia	54
Architecture	310
Basaltina	118
Beton	360
Cemento	368
Chalon	60
Città	404
Earth	302
Eco concrete	390
Granito evo	280
Kerblock	122
Kerinox	210
Lavagna	134
Macro	184
Manhattan	348
Marmoker	150
Marmosmart	172
Marte	188
Metallica	214
Metalwood	270
Meteor	72
Onici	200
Pietra Baugé	84
Pietre di Paragone	44
Pietre di Sardegna	90
Pietre Etrusche	112
R-evolution	354
Resina	378
Spazio	384
Steeltech	220

**→ 60x60 cm**

Stonewash	102
Terrazzo	178
Terre Toscane	106
Titano	126
Unicolore	322

**30x60 cm**

Amazzonia	54
Architecture	310
Basaltina	118
Beton	360
Boulder	66
Cemento	368
Chalon	60
Città	404
Earth	302
Eco concrete	390
Granito evo	280
Lavagna	134
Living	408
Manhattan	348
Marmoker	250
Marmosmart	172
Marte	188
Metallica	214
Metalwood	270
Meteor	72
Mineral Chrom	78
Pietra Baugé	84
Pietre di Paragone	44
Pietre di Sardegna	90
Pietre Etrusche	112
R-evolution	354
Spazio	384
Steeltech	220
Terrazzo	178
Terre Toscane	106
Unicolore	322

**15x60 cm**

Architecture	310
Marte	188
Pietre di Sardegna	90
Pietre Etrusche	112
Unicolore	322

**10x60 cm**

Metalwood	270
-----------	-----

**30x30 cm**

Agorà	142
Amazzonia	54
Architecture	320
Ardesia	130
Basaltina	118
Granito evo	280
Granito 1	284
Granito 2	290
Granito 3	294
Lavagna	134
Marte	190
Meteor	72
Mineral Chrom	78
Pietre di Sardegna	90
Pietre Etrusche	112
Spazio	384
Terre Toscane	106
Unicolore	322

**15x30 cm**

Agorà	142
Ardesia	130

**15x15 cm**

Agorà	142
Ardesia	130
Lavagna	134
Marte	190

**41,5x41,5 cm**

Living	408
--------	-----

**33x33 cm**

Living	408
--------	-----

**40x40 cm**

Granito 1	284
Marte	190
Unicolore	322

**20x40 cm**

Patio	138
-------	-----

**20x20 cm**

Caleidoscopio	328
Granito 1	284
Opus	394
Patio	138
Unicolore	322

**25x25 cm**

Elementi	334
Landscape	338

**12,5x25 cm**

Granito 1	284
Elementi	334
Landscape	338

**12,5x12,5 cm**

Elementi	334
Landscape	338

**6,5x25 cm**

Landscape	338
-----------	-----

# INDICE PER ARTICOLO INDEX BY ARTICLE INDEX PAR ARTICLE INDEX NACH ARTIKEL

## A

Acquamarina	324
Adria Smart	174
Ajaccio	296
Amalfi	292
Amazique	242
Antracite	331
Arabesque	155
Arborea	256
Architecture Acid Green	316
Architecture Beige	315
Architecture Black	312
Architecture Cool Grey	313
Architecture Dark Grey	312
Architecture Dark Ivory	314
Architecture Light Brown	314
Architecture Light Grey	313
Architecture Light Ivory	314
Architecture Medium Grey	312
Architecture Purple	316
Architecture Warm Grey	313
Architecture White	315
Ardesia Beige	132
Ardesia Bianco	132
Ardesia Grigio	132
Ardesia Nero	132
Ardesia Rosa	132
Ardesia Rosso	132
Ardesia Verde	132
Argento	272
Arizona	288
Arkansas	286
Artic 701	340
Atene	406
Avorio	332
Avorio 011	336
Azul Bahia	192
Azul Macauba	192

## B

Bahama 501	340
Bardiglio Bianco	156
Bardiglio Imperiale	153
Basalto 061	336
Baugé Antracite	86
Baugé Beige	86
Baugé Bianca	86
Baugé Grigia	86
Bay 200	340
Beach 101	340
Berlino	406
Beton Dark	362
Beton Ivory	362
Beton Mud	362
Beton Pearl	362
Beton Sand	362
Betulla	331
Bianco Assoluto	325
Bianco Avorio	325
Bianco Avorio Tactile	428
Bianco B	325
Bianco Vietnam	156
Birimbau	153
Blu Forte	324
Boston	282
Botticino	191
Breccia Carsica	153
Bronzetto	190
Brown Forest	153
Budapest	296
Budapest Tactile	428
Buxy	128

## C

Caen	128
Calacatta Extra	157
Cala Luna	92
Canova	156
Capalbio	115
Caprera	92
Caramel	332
Carbonio	272
Cardoso	128
Caribbean Green	154
Casablanca	296
Cemento 060	336
Cemento Cassero Antracite	370
Cemento Cassero Beige	370
Cemento Cassero Bianco	371
Cemento Cassero Grigio	370
Cemento Rasato Antracite	370
Cemento Rasato Beige	370
Cemento Rasato Bianco	371
Cemento Rasato Grigio	370
Cervinia	292
Chalon Beige	62
Chalon Cream	62
Chalon Grey	62
Chalon Kaki	62
Chambrod	128
Chicago	282
Cielo	331
Class Brown	238
Class Dove Grey	238
Class Grey	238
Class Walnut	238
Cloud	68
Cobalto	330
Colorado	288
Coral Rose	256
Corinto	144

Cortina	292
Country Bianco	232
Country Greige	232
Country Ice	232
Country Marrone	232
Country Tortora	232
Crema Marfil	191
Crema Select	155

**D**

Dakota	286
Denver	282
Dragon Beige	56
Dragon Black	56
Dragon Brown	56
Dragon Green	56
Dragon Grey	56
Dragon White	57

**E**

Earth Bianco	305
Earth Blu	304
Earth Brunello	304
Earth Grigio 1	305
Earth Grigio 2	305
Earth Grigio 3	304
Earth Grigio 4	304
Earth Metalred	304
Earth Tortora 1	304
Ebano 070	336
Eco Antracite	392
Eco Beige	392
Eco Bianco	392
Eco Cenere	392
Eco Grigio	392
Elatea	144
Eldorado	56
Emperador	190
Everest	286

**F**

Fior di pesco	174
Fossena Smart	379
Fossil	68

**G**

Gaiole	108
Gallipoli	292
Gelsomino	256
Georgia	287
Ghiaccio	331
Giallo Ocra	325
Giallo Ocra Tactile	428
Giamaica	286
Grafite	152
Granita	331
Gré Bianco	46
Gré Grigio	46
Gré Nero	46
Greve	108
Grigio Aitos	46
Grigio Ash	128
Grigio Cenere	324
Grigio Egeo	191
Grigio Maggia	190
Grigio Marostica	190
Grigio Perla	324
Grigio Tao	46

**H**

Harlem	350
Helix	256

**I**

Iberia	288
Ink	68
Inox	216
Iridio	272

Iroko	242
Ischia	120

**J**

Jolie	154
-------	-----

**K**

Kerblock Avorio	124
Kerblock Beige	124
Kerblock Nero	124
Kerblock Piombo	124
Kerinox Antracite	212
Kerinox Bianco	212
Kerinox Grigio	212
Kerinox Sabbia	212
Koa	242

**L**

Labrador	287
Lasa smart	175
Lava 700	340
Lavagna Bianca	136
Lavagna Grigia	136
Lavagna Nera	136
Linosa	120
Lipari	120
Liquirizia	330
Lisbona	406
Living Beige	410
Living Black	410
Living Grey	410
Living Ice	410
Living Noisette	410
Living White	410
Londra	406
Luni	47

# INDICE PER ARTICOLO INDEX BY ARTICLE INDEX PAR ARTICLE INDEX NACH ARTIKEL

## M

Macro Bianco	186
Macrio Carnico	186
Macro Grigio	186
Macro Moro	186
Madrid Tactile	428
Manciano	114
Mare 021	336
Marina	330
Marquina Smart	174
Megalopoli	144
Menta	330
Meteor Almond	75
Meteor Beige	77
Meteor Bianco	74
Meteor Brown	75
Meteor Grafite	74
Meteor Grigio	74
Meteor Nero	74
Meteor Noce	74
Meteor Perla	75
Milano	292
Mineral Beige	80
Mineral Black	80
Mineral Brown	80
Mineral Gold	80
Mineral Grey	80
Mineral White	80
Montepulciano	108
Monteriggioni	108
Montreal	296
Mosca	406

## N

Nebraska	287
Nero	324
Nero Acapulco	190
Nero Creta	152

Nevada	287
New York	282
Newood Beige	267
Newood Black	266
Newood Brown	266
Newood Cream	266
Newood Grey	266
Newood Ivory	267
Newood Wengè	266
Newood White	267
Night Storm	152

## O

Ocean 202	341
Ocra	332
Olimpo	156
Oliva	330
Onice Avorio	202
Onice Bianco	202
Onice Ghiaccio	202
Onice Miele	202
Onice Quarzo	202
Onsernone	46
Ontario	286
Opus Beige	396
Opus Grigio	396
Orange Black	152
Ossidiana	152
Oyster Grey	153

## P

Paestum	115
Palissandro	191
Pantelleria	120
Patio Beige	140
Patio Gold	140
Patio Grey	140
Patio White	140

Pietra del Cardoso	46
Pietra Piasentina New	47
Pietrasanta Smart	175
Piombo	272
Pistacchio	330
Pitigliano	114
Planks Beige	252
Planks Bianco	252
Planks Bruno	252
Planks Grigio	252
Planks Muschio	252
Platino	273
Porto Cervo	92
Porto Rotondo	93
Praga	407
Pulpis Tortora	154
Punta Molara	92

## Q

Queens	350
--------	-----

## R

R-evolution Azure	357
R-evolution Black	356
R-evolution Blue	356
R-evolution Dark Grey	356
R-evolution Green	357
R-evolution Grey	357
R-evolution Light Pink	357
R-evolution Sand	356
R-evolution Terra	356
R-evolution Tortora	356
R-evolution Total White	357
R-evolution White	357
Raggio di Luna	191
Ramora Brown	190
Resina Black	380
Resina Grey	380
Resina Havana	380

Resina Tobacco	380
Resina White	380
Rosato	155
Rosso Francia	153
Rosso Mattone	325
Rosso Selenio	332
Rust	68

**S**

Sahara	286
Saint Laurent	152
San Casciano	108
Saturnia	114
Seattle	282
Shanghai	296
Shanghai Tactile	428
Siena	292
Silicio	272
Soho	350
Sovana	114
Sparta	144
Spazio Antracite	386
Spazio Argento	386
Spazio Beige	386
Spazio Bianco	387
Spazio Grigio	387
Spazio Perla	386
Spazio Tabacco	386
Spazio Tortora	386
Statuarietto Smart	175
Statuario Grigio	157
Statuario Oro	157
Steeltech Antracite	222
Steeltech Beige	222
Steeltech Corten	222
Steeltech Grigio	222
Stintino	92
Stoccolma	406
Stromboli	120

**T**

Talco 010	336
Tarquinia	115
Tavolara	92
Tavolato Antracite	246
Tavolato Grano	246
Tavolato Marrone Chiaro	246
Tavolato Marrone Medio	246
Tavolato Marrone Scuro	246
Tavolato Sbiancato	247
Thassos	191
Terrazzo Beige	180
Terrazzo Black	180
Terrazzo Grey	180
Terrazzo Pearl	180
Terrazzo White	180
Tokyo	296
Tortora Smart	174
Titan White	156
Tivoli Smart	174
Travertino Bianco	156
Travertino Miele	155
Travertino Romano	155
Travertino Titanium	154
Tribeca	350
Tucson	282
Tundra 100	340
Tuscania	114

**U**

Ulivo Grigio	260
Ulivo Noce	260
Ulivo Panna	260
Ulivo Tortora	260

**V**

Vagli Smart	174
Vals	47
Verde	324
Verde Aver	154
Verde Guatemala	192
Verrazzano	108
Vulcano	120
Vulci	114

**W**

Wash Brown	104
Wash Cream	104
Wash Grey	104
White Oak	242

**Z**

Zebrawood	242
Zebrino	155
Zinco-Titanio	216

# La ceramica, una scelta sicura

Ceramic: a safe choice La céramique, un choix sûr Keramik, eine sichere Wahl

Scegliere la ceramica nella moderna progettazione, significa valorizzare le qualità di un materiale nobile, naturale e performante. La ceramica è anallergica e inodore perchè non trattiene lo sporco e i batteri ed è facile da pulire. Altamente resistente a qualsiasi tipo di sollecitazione chimica e meccanica, garantisce una lunga durata nel tempo, non brucia e non rilascia sostanze nocive: per questo è bella, sicura e adatta a diverse destinazioni d'uso, grazie alla ricca gamma di superfici, formati e spessori. Inoltre è un materiale completamente riciclabile, non contiene plastica e viene realizzata secondo processi produttivi che rispettano l'ambiente e la salute.

Choosing ceramic in modern architecture means emphasising the quality of this noble, natural, high-performance material.

Ceramic is non-allergic and odourless because it doesn't retain dirt and bacteria, and it's easy to clean. It withstands any chemical or mechanical stress, it's long-lasting, it doesn't burn and doesn't release harmful substances.

With its wide range of surfaces, sizes, and thicknesses, ceramic is beautiful, safe, and suitable for any use.

Moreover, it's fully recyclable, it doesn't contain plastic, and it's made with production processes that help protect both the environment and human health.

Choisir la céramique dans la conception moderne signifie mettre en valeur les qualités d'un matériau noble, naturel et performant. Facile à nettoyer, la céramique est anallergique et inodore car elle ne retient ni la saleté ni les bactéries. Fortement résistante à tout type de sollicitation chimique et mécanique, elle est durable dans le temps, ne brûle pas et ne libère aucune substance nocive. C'est pourquoi elle est élégante, sûre et, grâce à la riche gamme de surfaces, de formats et d'épaisseurs, adaptée à différentes applications. De plus, il s'agit d'un matériau entièrement recyclable, sans traces de plastique, et qui est réalisé conformément à des processus de production respectueux de l'environnement et de la santé.

Die Wahl von Keramik bedeutet im modernen Design, die Eigenschaften eines edlen, natürlichen und leistungsfähigen Materials zu würdigen. Keramik ist hypoallergen und geruchsneutral, da sie keinen Schmutz und keine Bakterien annimmt und leicht zu reinigen ist. Sie widersteht jeder Art von chemischer und mechanischer Beanspruchung, gewährleistet eine lange Lebensdauer, brennt nicht und setzt keine schädlichen Substanzen frei. Aus diesem Grund ist sie schön, sicher und dank der großen Auswahl an Oberflächenausführungen, Formaten und Stärken für unterschiedlichste Anwendungen geeignet. Darüber hinaus stellt sie ein vollständig recycelbares Material dar, enthält keine Kunststoffe und wird in umwelt- und gesundheitsschonenden Fertigungsverfahren hergestellt.

## bios self-cleaning\*

È la soluzione innovativa per i rivestimenti di facciata, in grado di qualificare gli involucri architettonici con elevate prestazioni di autopulizia e di abbattimento degli agenti inquinanti.

An innovative façade cladding solution that ensures high self-cleaning and pollution abatement performance for architectural envelopes.

Est une solution innovante pour les revêtements de façade qui permet de créer des enveloppes architecturales aux performances élevées d'autonettoyage et d'élimination des agents polluants.

Ist eine innovative Lösung für Fassadenverkleidungen, die Gebäudehüllen mit verbesserten selbstreinigenden Eigenschaften und der Fähigkeit zum Abbau von Schadstoffen aufwerten kann.

## bios antibacterial\*

È la linea di prodotti da rivestimento e pavimentazione in gres porcellanato capaci di abbattere al 99,9% i quattro principali ceppi batterici presenti negli ambienti confinati.

A range of porcelain stoneware flooring and wall covering products that can remove up to 99.9% of the four most common bacterial strains in confined environments.

Est la ligne de produits de revêtement de sol et de mur en grès cérame en mesure d'éliminer à 99,9 % les quatre principales souches bactériennes présentes dans les espaces confinés.

Ist eine Produktlinie an Wandverkleidungen und Bodenbelägen aus Feinsteinzeug, die bis zu 99,9 % der in geschlossenen Räumen auftretenden vier hauptsächlichen Bakterienstämme abtöten können.

## SOSTENIBILE SUSTAINABLE DURABLE NACHHALTIG

Completamente riciclabile. Non contiene plastica. Fully recyclable. Does not contain plastic.

Entièrement recyclable. Ne contient pas de plastique. Vollständig recycelbar. Enthält keine Kunststoffe.

## ECOLOGICA ENVIRONMENTALLY FRIENDLY ÉCOLOGIQUE UMWELTFREUNDLICH

Rispetta ambiente e salute. Conforme alle normative europee.

Helps protect the environment and human health.

Meets all applicable European standards.

Respecte l'environnement et la santé.

Conforme aux réglementations européennes.

Schont Umwelt und Gesundheit.

Entspricht den europäischen Normen.

## IGIENICA IHYGIENIC HYGIÉNIQUE HYGIENISCH

Inodore, non trattiene sporco e batteri. Facile da pulire.

Odourless, does not retain dirt and bacteria. Easy to clean.

Inodore, ne retient ni la saleté ni les bactéries.

Facile à nettoyer.

Geruchsneutral, nimmt keinen Schmutz und keine Bakterien an. Leicht zu reinigen.

## DUREVOLE LONG-LASTING RÉSISTANTE LANGLEBIG

Resistente a sollecitazioni esterne e abrasioni.

Withstands abrasion and stress.

Résistante aux sollicitations extérieures et aux abrasions.

Widersteht äußeren Beanspruchungen und Abrieb.

## IGNIFUGA FIRE-RESISTANT IGNIFUGE FEUERFEST

Non brucia. Non rilascia sostanze nocive.

Does not burn. Does not release harmful substances.

Ne brûle pas. Ne libère aucune substance nocive.

Brennt nicht. Setzt keine schädlichen Substanzen frei.

## STABILE STABLE STABLE STABIL

Colori inalterabili nel tempo. Non si deforma.

Colours don't fade over time. Does not warp.

Couleurs inaltérables dans le temps. Ne se déforme pas.

Behält die Farbe über den Lauf der Zeit unverändert.

Verformt sich nicht.

## INGELIVA FROST-RESISTANT INGÉLIVE FROSTBESTÄNDIG

Resiste al gelo e agli sbalzi di temperatura.

Withstands frost and temperature fluctuations.

Résiste au gel et aux écarts de température.

Widersteht Frost und Temperaturschwankungen.

## INASSORBENTE NON-ABSORBENT IMPERMÉABLE NICHT-ABSORBIEREND

Non assorbe acqua.

Does not absorb water.

Imperméable à l'eau.

Nimmt kein Wasser auf.

## RESISTENTE STURDY SOLIDE WIDERSTANDSFÄHIG

Inattaccabile da agenti chimici aggressivi.

Resists aggressive chemicals.

Inattaquable par les agents chimiques agressifs.

Beständig gegenüber aggressiven Chemikalien.

# Un impegno concreto, per uno sviluppo sostenibile

Our commitment towards sustainable development **Un engagement concret pour un développement durable** Ein konkretes Engagement für eine nachhaltige Entwicklung

Produrre materiali ceramici evoluti ed ecologici in un corretto equilibrio tra rispetto delle risorse naturali, protezione dell'ambiente, progresso tecnologico, crescita economica e responsabilità sociale sono caratteri profondamente radicati nel DNA di Casalgrande Padana. Priva di smalti e costituita esclusivamente da materie prime naturali la ceramica è ottenuta mediante un processo produttivo a ciclo chiuso, dove sofisticate apparecchiature antinquinamento consentono il riciclo e il recupero completo di tutte le componenti, con emissioni e dispersioni sostanzialmente nulle. Resistente, duratura e affidabile, la ceramica è una scelta progettuale decisamente orientata ai principi della sostenibilità.

Casalgrande Padana manufactures state-of-the-art ceramic materials keeping a perfect balance between natural resource protection, environment protection, advanced technology, economic growth, and social responsibility. Our ceramic is glaze-free and made exclusively from natural raw materials through a closed-cycle manufacturing process where sophisticated antipollution equipment allow all the components to be recycled and reused, with substantially zero emissions or dispersions. Ceramic is sturdy, long-lasting, and reliable. The perfect choice for sustainable architecture.

Produire des matériaux céramiques innovants et écologiques en maintenant un bon équilibre entre le respect des ressources naturelles, la protection de l'environnement, le progrès technologique, la croissance économique et la responsabilité sociale sont des éléments profondément ancrés dans l'ADN de Casalgrande Padana. Sans émail et réalisée exclusivement à partir de matières premières naturelles, la céramique est obtenue à travers un processus de production à circuit fermé, où des équipements sophistiqués antipollution permettent le recyclage et la récupération complète de tous les composants, avec des émissions et des dispersions pratiquement nulles. Résistante, durable et fiable, la céramique est un choix de conception fortement orienté vers les principes de la durabilité.

Fortschrittliche und ökologische Keramikmaterialien in der richtigen Balance zwischen Wahrung natürlicher Ressourcen, Umweltschutz, technischer Entwicklung, wirtschaftlichem Wachstum und sozialer Verantwortung herzustellen, ist eine Eigenschaft, die zutiefst in der DNS von Casalgrande Padana verankert ist. Ohne Lacke und ausschließlich aus natürlichen Rohstoffen gefertigt, wird Keramik in einem Herstellungsprozess mit geschlossenem Kreislauf gewonnen, in dem hochentwickelte Anlagen zur Vermeidung von Umweltverschmutzung das vollständige Recycling und die Rückgewinnung aller Komponenten ohne substanzielle Emissionen und Dispersionen ermöglichen. Aufgrund ihrer Widerstandsfähigkeit, Langlebigkeit und Zuverlässigkeit ist Keramik eine Gestaltungswahl, die sich entschieden an den Prinzipien der Nachhaltigkeit orientiert.



UNI EN ISO 14001:2015



SISTEMA DI GESTIONE AMBIENTALE CERTIFICATO



Casalgrande Padana ha adottato un sistema di gestione ambientale conforme al Regolamento EMAS allo scopo di attuare il miglioramento continuo delle proprie prestazioni ambientali pubblicando una dichiarazione ambientale convalidata dall'ente certificatore.

Casalgrande Padana has adopted an environmental management system that complies with the EMAS regulation to continuously improve our environmental performance. We have also published the environmental statement validated by the certification body.

Casalgrande Padana a adopté un système de gestion environnementale conforme au règlement SMEA afin de mettre en œuvre une amélioration continue de ses performances environnementales en publiant une déclaration environnementale validée par l'organisme certificateur.

Casalgrande Padana hat ein der EMAS-Verordnung entsprechendes Umweltmanagementsystem eingeführt, um die kontinuierliche Verbesserung seiner Umwelleistung durch die Veröffentlichung einer von der Zertifizierungsstelle validierten Umwelterklärung zu erreichen.



**MATERIE PRIME RECUPERATE** RECOVERED RAW MATERIALS **MATIÈRES PREMIÈRES RÉCUPÉRÉES** WIEDERGEGWONNE NE ROHSTOFFE

Utilizzo di scarti calcolati sul volume di produzione 2019.

Use of scrap calculated on the 2019 production volume.

Utilisation des déchets calculés sur le volume de production 2019.

Verwendung von Ausschussmaterialien, berechnet auf die Produktionsmenge 2019.



100%

**IMBALLI ECOCOMPATIBILI** ECO-COMPATIBLE PACKAGING **EMBALLAGES ÉCOCOMPATIBLES** UMWELTFREUNDLICHE VERPACKUNGEN

Impiego di Pallet Fao e imballi realizzati con materiali riciclati.

We use FAO pallets and packaging made with recycled materials.

Utilisation de palettes FAO et d'emballages réalisés avec des matériaux recyclés.

Verwendung von FAO-Paletten und Verpackungen aus recycelten Materialien.



**SISTEMA DI GESTIONE SICUREZZA CERTIFICATO** UNI ISO 45001:2018

CERTIFIED SAFETY MANAGEMENT SYSTEM UNI ISO 45001:2018 **SYSTEME DE GESTION SÉCURITÉ CERTIFIÉ** UNI ISO 45001:2018 NACH ISO 45001:2018 ZERTIFIZIERTES QUALITÄTSMANAGEMENTSYSTEM

Produzione e commercializzazione di pavimenti e rivestimenti in ceramica.

Production and marketing of ceramic floor and wall tiles.

Production et commercialisation de revêtements de sol et de mur en céramique.

Herstellung und Vermarktung von Bodenbelägen und Wandverkleidungen aus Keramik.



**ENERGIA AUTOPRODOTTA** SELF-PRODUCED ENERGY **ÉNERGIE AUTOPRODUITE** SELBST PRODUZIERTER STROM

Generata da impianti fotovoltaici e di cogenerazione. Thanks to our cogeneration and photovoltaic systems.

Générée par des systèmes photovoltaïques et de cogénération.

Erzeugt durch Photovoltaik- und KWK-Anlagen.



100%

**RIDUZIONE DELL'IMPATTO IDRICO** WATER IMPACT REDUCTION **RÉDUCTION DE L'IMPACT SUR L'EAU** REDUZIERUNG DES WASSERVERBRAUCHS

Recupero delle acque reflue nel processo produttivo. Wastewater recovery during the production process.

Récupération des eaux usées dans le processus de production.

Rückgewinnung von Abwasser im Produktionsprozess.



99,5%

**RIFIUTI RECUPERATI** WASTE RECOVERED **DÉCHETS RÉCUPÉRÉS** **ABFALLVERWERTUNG**

Inviati alla raccolta differenziata. Thanks to separate waste collection.

Envoyés au tri.

Zu Sammelstellen transportiert.





# bios. ceramics®

## CERAMICHE BIOATTIVE

Innovativa tipologia di prodotti eco-compatibili, in grado di interfacciarsi autonomamente con l'ambiente, per generare una serie di processi virtuosi, quali in particolare, reazioni di tipo chimico e biologico, capaci di ricadute positive in termini antibatterici, di abbattimento degli agenti inquinanti, di autopulibilità delle superfici e capaci di contribuire in maniera determinante all'innalzamento della qualità del microambiente (interno o esterno) in cui gli elementi ceramici vengono messi in opera. I processi avvengono grazie alla particolare natura dei materiali e dei trattamenti, senza alcuna necessità di alimentazione elettrica, energetica o del rinnovo dei composti necessari a sostenere nel tempo la reazione.

## BIOACTIVE CERAMICS

Innovative kind of environment-friendly products that can independently interface with the environment to create a number of virtuous processes, such as chemical and biological reactions that have an air pollutant reducing and antibacterial effect and trigger the self-cleaning of the surfaces, thus remarkably contributing to improving the quality of the (internal or external) micro-environment in which the ceramics are installed. Such processes take naturally place thanks to the materials and treatments, without any electricity or energy, and without having to renew the compounds necessary to prolong the reaction.



**Bios Ceramics®**, è la più avanzata ed esclusiva generazione di ceramiche bioattive per applicazioni architettoniche, certificate ed ecocompatibili, con caratteristiche antibatteriche, autopulenti e di riduzione degli agenti inquinanti.

La produzione si articola nell'ambito di due trattamenti estremamente specializzati e continuamente soggetti a migliorie prestazionali, Bios Self-Cleaning® e Bios Antibacterial®, in grado di rispondere a qualsiasi esigenza applicativa in interni ed esterni, in funzione delle specifiche condizioni di impiego. Una proposta trasversale e diversificata che in oltre vent'anni di sperimentazione ha permesso di soddisfare la creatività di progettisti e clienti in tutto il mondo, grazie alle ricercate finiture e ai diversi formati disponibili su tutta la gamma prodotti di Casalgrande Padana.

#### L'OFFERTA COMPRENDE:

**Bios Self-Cleaning®**, lastre in gres porcellanato per la realizzazione di rivestimenti esterni di facciata. Grazie allo speciale trattamento basato sulla tecnologia Hydrotect®, in presenza di luce solare Bios Self-Cleaning® attiva una reazione in grado di abbattere non solo i batteri ma soprattutto gli inquinanti presenti nell'aria e decomporre lo sporco che si deposita sulla superficie delle piastrelle, in modo che venga rimosso dall'acqua piovana, grazie alla super-idrofilia della superficie ceramica.

**Bios Antibacterial®**, pavimenti e rivestimenti in gres porcellanato con assolute proprietà antibatteriche, conformi alla regolamentazione europea, efficaci in qualsiasi condizione di luce, anche al buio, capaci di abbattere al 99,9% i principali ceppi batterici presenti sulle superfici: Escherichia coli, Pseudomonas aeruginosa, Staphylococcus aureus, Enterococcus faecalis.

**Bios Ceramics®** is the most advanced, exclusive generation of certified, eco-compatible bioactive ceramics for architectural applications. It has antibacterial and self-cleaning properties, and is able to reduce polluting agents.

It comprises two highly specialised treatments with continually improving performance, Bios Self-Cleaning® and Bios Antibacterial®, able to meet all kinds of application requirements indoors and outdoors, depending on the specific conditions of use. In over 20 years of experimentation, this versatile, diversified solution has made it possible to satisfy the creativity of architects, designers and customers worldwide, thanks to the sophisticated finishes and different formats available across the entire Casalgrande Padana range.

#### THE RANGE INCLUDES:

**Bios Self-Cleaning®** porcelain stoneware tiles for covering external façades. The special treatment based on the Hydrotect® technology allows Bios Self-Cleaning® to activate a reaction in the presence of sunlight. This reaction reduces air pollutants and decomposes dirt deposits, which are washed away by rainwater, thanks to the superhydrophilicity of the ceramic surface.

**Bios Antibacterial®**, porcelain stoneware floorings and coverings with top antibacterial properties, compliant with European regulations, effective in all kinds of light conditions, even in the dark, and able to remove up to 99.9% of the main strains of bacteria present on surfaces: Escherichia coli, Pseudomonas aeruginosa, Staphylococcus aureus and Enterococcus faecalis.



**Bios Ceramics®** est la génération la plus avancée et la plus exclusive de céramiques bioactives pour des applications architecturales, certifiées et écocompatibles, offrant des caractéristiques antibactériennes, autonettoyantes et de réduction des agents polluants.

La production s'articule autour de deux traitements extrêmement spécialisés et soumis en permanence à des améliorations en termes de performances, Bios Self-Cleaning® et Bios Antibacterial®, capables de répondre à toute exigence d'application à l'intérieur comme à l'extérieur, en fonction des conditions d'utilisation spécifiques. Il s'agit d'une proposition transversale et diversifiée qui, au cours de plus de vingt années d'expérimentations, a permis de satisfaire la créativité des concepteurs et des clients dans le monde entier. Et ce, grâce aux finitions raffinées et aux différents formats disponibles sur toute la gamme des produits de Casalgrande Padana.

ELLE COMPREND :

**Bios Self-Cleaning®**, dalles en grès cérame pour la réalisation de revêtements extérieurs de façade. Grâce à un traitement spécial basé sur la technologie Hydrotect®, Bios self-cleaning® déclenche en présence de lumière solaire une réaction capable d'éliminer les polluants présents dans l'air, de décomposer les saletés déposées en surface et de les éliminer grâce à l'eau de pluie et aux propriétés ultra-hydrophiles de la surface céramique.

**Bios Antibacterial®**, revêtements de sol et de mur en grès cérame aux propriétés antibactériennes absolues, conformes à la réglementation européenne, efficaces dans toutes les conditions de luminosité, y compris la nuit, capables d'éliminer à 99,9 % les principales souches bactériennes présentes sur les surfaces : Escherichia coli, Pseudomonas aeruginosa, Staphylococcus aureus, Enterococcus faecalis.

**Bios Ceramics®** ist die modernste und exklusivste Generation bioaktiver Keramiken für Anwendungen in der Architektur. Sie ist zertifiziert und umweltfreundlich, mit antibakteriellen, selbstreinigenden und schadstoffreduzierenden Eigenschaften.

Die Produktpalette gliedert sich in zwei äußerst spezialisierte Behandlungen, die kontinuierlich in ihrer Leistungsfähigkeit verbessert werden: Bios Self-Cleaning® und Bios Antibacterial®, die entsprechend den spezifischen Einsatzbedingungen für alle Anwendungsanforderungen im Innen- und Außenbereich geeignet sind. Es handelt sich um ein transversales und diversifiziertes Produktangebot, mit dem in mehr als zwanzig Jahren des Experimentierens die Kreativität von Designern und Kunden aus aller Welt verwirklicht werden konnte und zwar dank der anspruchsvollen Oberflächen und der verschiedenen Formate, die für das gesamte Produktsortiment von Casalgrande Padana angeboten werden.

DAS ANGEBOT UMFASST:

**Bios Self-Cleaning®** – Feinsteinzeugplatten für Außenfassadenverkleidungen. Dank der Spezialbehandlung auf Grundlage der HYDROTECT®-Technologie ruft Bios Self-Cleaning® im Sonnenlicht eine Reaktion hervor, die die vorhandene Luftverschmutzung bindet und den sich auf den Fliesenoberflächen absetzenden Schmutz zersetzt. Dieser kann dann in der Folge dank der super-hydrophilen Keramikoberfläche vom Regenwasser abgewaschen werden.

**Bios Antibacterial®** – Boden- und Wandfliesen aus Feinsteinzeug mit uneingeschränkt antibakteriellen Eigenschaften gemäß den europäischen Vorschriften. Sie sind bei allen Lichtverhältnissen wirksam, auch bei Dunkelheit, und in der Lage, 99,9 % der wichtigsten Bakterienstämme, die auf Oberflächen vorhanden sind, abzutöten: Escherichia coli, Pseudomonas aeruginosa, Staphylococcus aureus und Enterococcus faecalis. konzipiert für das Verlegen von Bodenbelägen und Wandverkleidungen mit herausragenden antibakteriellen Eigenschaften, die bis zu 99,9 % der in geschlossenen Räumen auftretenden hauptsächlichsten Bakterienstämme abtöten können: Escherichia coli, Pseudomonas aeruginosa, Staphylococcus aureus, Enterococcus faecalis.

# bios self-cleaning®

Una soluzione innovativa per i rivestimenti di facciata, in grado di qualificare gli involucri architettonici con elevate prestazioni di autopulizia e di abbattimento degli agenti inquinanti.

An innovative façade cladding solution that ensures high self-cleaning and pollution abatement performance for architectural envelopes.

Une solution innovante pour les revêtements de façade, en mesure de donner aux enveloppes architecturales d'excellentes performances d'autonettoyage et d'élimination des agents polluants.

Eine innovative Lösung für Fassadenverkleidungen, die Gebäudehüllen durch verbesserte selbstreinigende Eigenschaften und die Fähigkeit zum Abbau von Schadstoffen aufwertet.

## PROPRIETÀ SUPER IDROFILE SUPER-HYDROPHILIC PROPERTIES PROPRIÉTÉ SUPER-HYDROPHILE SUPER HYDROPHILE EIGENSCHAFTEN

Lastra ceramica tradizionale  
Traditional ceramic slab  
Dalle céramique ordinaire  
Traditionelle Keramikplatte



Lastra ceramica trattata  
Bios Self-Cleaning®  
Bios Self-Cleaning®  
ceramic slab  
Dalle céramique traitée  
avec Bios Self-Cleaning®  
Mit Bios Self-Cleaning®  
behandelte Keramikplatte



unicolore bios bianco assoluto cm 10x60 - 4"x23<sup>5</sup>/<sub>8</sub>"

## LA TECNOLOGIA HYDROTECT®

La tecnologia **HYDROTECT®** viene utilizzata su licenza da oltre 100 produttori di tutto il mondo, nei più differenti settori applicativi, dall'industria automobilistica alle costruzioni. Detentore del brevetto è il gruppo giapponese TOTO, leader globale nel settore delle tecnologie fotocatalitiche, con il quale **Casalgrande Padana** ha sottoscritto un Master Agreement. Grazie a questa tecnologia le ceramiche **Bios Self-Cleaning®** utilizzate nei rivestimenti di facciata ed involucri ventilati, offrono significative risposte in termini di capacità autopulente e di abbattimento dei NOx (ossidi e miscele di azoto, tra i principali inquinanti dell'atmosfera urbana). In particolare, **Bios Self-Cleaning®** aggiunge alle caratteristiche estetiche e prestazionali dei rivestimenti ceramici in grès porcellanato, il drastico abbattimento degli interventi di pulizia e manutenzione delle superfici, garantendo un sensibile risparmio in termini economici e il mantenimento delle qualità e dell'aspetto del manufatto architettonico.

## LE CARATTERISTICHE BIOATTIVE PER I RIVESTIMENTI ESTERNI

L'esclusiva formulazione di **Bios Self-Cleaning®** è a base di biossido di titanio (TiO<sub>2</sub>), una sostanza naturale, non nociva, tradizionalmente utilizzata come pigmento bianco e per confezionare additivi alimentari, dentifrici, prodotti cosmetici eccetera.

Il biossido di titanio conferisce alle superfici **Bios Self-Cleaning®**:

- caratteristiche fotocatalitiche che, in presenza di irraggiamento luminoso, consentono di decomporre le sostanze organiche e gli inquinanti depositati sulle piastrelle, garantendo proprietà autopulenti e di purificazione dell'aria.
- caratteristiche di super-idrofilia, che ne esaltano la capacità di auto detergersi.

Tanto è maggiore l'irraggiamento con luce UV della superficie trattata, tanto diminuisce il suo angolo di contatto con l'acqua, che tende addirittura a zero dopo un ragionevole intervallo di tempo. L'acqua si spande e dilava con facilità. In pratica, all'azione del biossido di titanio che disgrega i depositi organici presenti sulla superficie trattata, grazie alla fotocatalisi, si aggiunge quella idrofila, che consente all'acqua piovana di detergere le piastrelle, asportando le macchie dalla loro superficie.

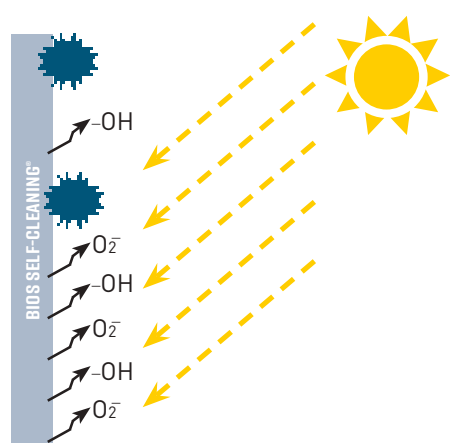

Quando la luce del sole (raggi UVA) irradia la superficie di **Bios Self-Cleaning®** si genera ossigeno attivo (O<sub>2</sub><sup>-</sup>, -OH)

When sunlight (UVA rays) hits the surface of the **Bios Self-Cleaning®**, active oxygen (O<sub>2</sub><sup>-</sup>, -OH) forms

La lumière du soleil (rayons UVA) qui rayonne sur la surface de **Bios Self-Cleaning®** génère de l'oxygène actif (O<sub>2</sub><sup>-</sup>, -OH)

Wenn das Sonnenlicht (UVA-Strahlen) die Oberflächen von **Bios Self-Cleaning®** bestrahlt, wird Aktivsauerstoff erzeugt (O<sub>2</sub><sup>-</sup>, -OH)

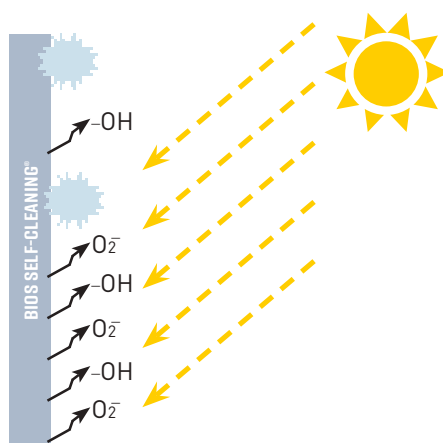

L'ossigeno attivo (O<sub>2</sub><sup>-</sup>, -OH) decompone lo sporco in sostanze meno aderenti

Active oxygen (O<sub>2</sub><sup>-</sup>, -OH) decomposes dirt into less adhesive substances

L'oxygène actif (O<sub>2</sub><sup>-</sup>, -OH) décompose les salissures en substances moins adhérentes

Der Aktivsauerstoff (O<sub>2</sub><sup>-</sup>, -OH) zersetzt den Schmutz in weniger haftfähige Stoffe

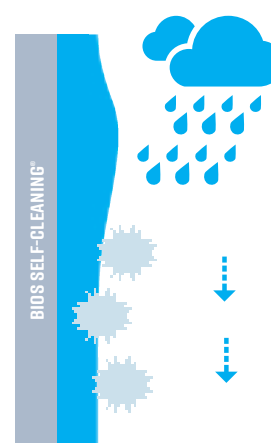

L'acqua piovana si espande sulla superficie di **Bios Self-Cleaning®** generando un sottilissimo strato che deterge ed elimina lo sporco precedentemente decomposto dall'ossigeno attivo

Rainwater spreads onto the **Bios Self-Cleaning®** surface, forming an extremely thin layer that cleanses and removes the dirt that has been decomposed by the active oxygen

L'eau de pluie glisse sur la surface de **Bios Self-Cleaning®** en constituant une fine couche d'eau qui nettoie et élimine les salissures précédemment décomposées

Das Regenwasser breitet sich auf der Oberfläche von **Bios Self-Cleaning®** aus und erzeugt einen hauchdünnen Film, der den zuvor vom Aktivsauerstoff zersetzten Schmutz reinigt und beseitigt

■ Sporco Dirt Salissures Schmutz

■ Sporco decomposto Decomposed dirt Salissures décomposées Zersetzter Schmutz

# bios self-cleaning®

## HYDROTECT® TECHNOLOGY

The **HYDROTECT®** technology has been licensed out to over 100 manufacturers all over the world in the most diverse areas of application, from car-making to building. The owner of the patent is the Japanese holding TOTO, a global leader in photo-catalytic technology, with which **Casalgrande Padana** has entered into a Master Agreement. With the **HYDROTECT®** technology, the **Bios Self-Cleaning®** ceramics in facings and ventilated walls provide important responses through their self-cleaning and NOx-reduction properties (NOx are nitrogen oxides and compounds, largely responsible for urban air pollution).

In particular, **Bios Self-Cleaning®** can combine the well-known aesthetic features and performance of unglazed stoneware ceramic facings with a dramatic reduction in the need to clean or maintain the surfaces, which translates into remarkable savings and a long-lasting quality and appearance of the architectural features.

## BIOACTIVE PROPERTIES FOR EXTERIOR FACINGS

The exclusive formulation of **Bios Self-Cleaning®** contains titanium dioxide (TiO<sub>2</sub>), a natural substance traditionally used as a white pigment and to make food additives, toothpaste, makeup and so on. Because of its titanium dioxide content, **Bios Self-Cleaning®** can perform to the highest standards, especially as a facing, to which it adds:

- photo-catalytic properties, which, when triggered by light, can break up the organic substances and pollutants on the tile surface for a self-cleaning, air cleansing effect.
- super-hydrophilic properties, which make the most of its self-cleaning properties.

The higher the UV light on the treated surface, the smaller its angle of contact with water, which after a reasonable time is next to zero.

This means that the water will easily spread and wash off. Basically, the effect of the titanium dioxide that breaks up the organic matter on the treated surface is supported, through photo-catalysis, by the hydrophilic effect, whereby rainwater washes off any stain from the tile surface.

## LA TECHNOLOGIE HYDROTECT®

Plus de 100 fabricants dans le monde entier utilisent, sous licence, la technologie **HYDROTECT®**, ceci dans les secteurs les plus variés, de l'industrie automobile au bâtiment. Le groupe japonais TOTO est titulaire du brevet et leader mondial dans le secteur des technologies photo-catalytiques. **Casalgrande Padana** a signé un Master Agreement avec le groupe Toto. Grâce à la technologie **HYDROTECT®**, les céramiques **Bios Self-Cleaning®**, utilisées pour les revêtements de façades traditionnelles et/ou ventilées, offrent des réponses significatives en termes de capacité autonettoyante et d'abattement des NOx (oxydes et mélanges d'azote, parmi les principaux polluants de l'air en milieu urbain).

En particulier, **Bios Self-Cleaning®** est en mesure d'allier les caractéristiques esthétiques et les performances des revêtements céramiques en grès cérame, à une importante diminution des opérations d'entretien et de nettoyage des surfaces, en garantissant pendant de longues années des économies en termes de coûts et du maintien de la qualité et de l'aspect du bâtiment.

## LES CARACTÉRISTIQUES BIOACTIVES POUR LES REVÊTEMENTS D'EXTÉRIEUR

La formule exclusive de **Bios Self-Cleaning®** est à base de dioxyde de titane (TiO<sub>2</sub>), une substance naturelle, couramment utilisée en tant que pigment blanc mais aussi pour fabriquer des additifs alimentaires, dentifrices, produits cosmétiques, etc.



Grâce au dioxyde de titane, **Bios Self-Cleaning®** est en mesure de garantir d'excellentes prestations, notamment comme revêtement de façade, en conférant à celle-ci :

- Des caractéristiques photocatalytiques, qui en présence d'un rayonnement lumineux, permettent de décomposer les substances organiques et les polluants qui se déposent sur la surface des carreaux, en garantissant des propriétés autonettoyantes et de purification de l'air.
- Des caractéristiques super-hydrophiles qui en exaltent les propriétés autonettoyantes.

Plus le rayonnement UV sur la surface traitée est intense, plus l'angle de contact entre l'eau et la surface diminue, et peut même arriver à zéro après un certain laps de temps. Ainsi, en glissant sur la surface, l'eau la nettoie plus facilement. En pratique, l'action photocatalytique du dioxyde de titane dégrade les dépôts organiques présents sur la surface traitée, et conjuguée aux propriétés hydrophiles, l'eau de pluie nettoie les carreaux en éliminant ainsi les salissures.

### **DIE HYDROTECT®-TECHNOLOGIE**

Die Technologie **HYDROTECT®** wird unter Lizenz von mehr als 100 Produzenten in aller Welt verwendet und zwar in unterschiedlichsten Anwendungsbereichen, von der Automobilindustrie bis zum Bauwesen. Der Patentinhaber ist der japanische Konzern TOTO, das weltweit führende Unternehmen im Bereich der fotokatalytischen Technologien, mit dem **Casalgrande Padana** ein Master Agreement abgeschlossen hat. Dank der **HYDROTECT®** Technologie bieten die für die Gestaltung von Fassaden und hinterlüfteten Fassaden verwendeten Keramikprodukte **Bios Self-Cleaning®** bedeutende Lösungen in puncto selbstreinigende Fähigkeit und NOx-Abbau (Oxide und Stickstoffmischungen, die zu den Hauptschadstoffen der Stadtluft gehören). Insbesondere ist **Bios Self-Cleaning®** in der Lage, die

schon bekannten ästhetischen Eigenschaften und Leistungen der keramischen Feinsteinzeugbeläge mit einer drastischen Reduzierung der Reinigungs- und Instandhaltungseingriffe an den Oberflächen zu bereichern und garantiert dabei über viele Jahre hinweg eine merkbare Kosteneinsparung und das Aufrechterhalten der Vorzüge und des Erscheinungsbildes der architektonischen Struktur.

### **BIOAKTIVE EIGENSCHAFTEN FÜR EXTERNE VERKLEIDUNGEN**

Die exklusive Formel von **Bios Self-Cleaning®** baut auf Titandioxyd (TiO<sub>2</sub>) auf, ein natürlicher Stoff, der traditionell als weißes Pigment verwendet wird und für die Zubereitung von Lebensmittelzusatzstoffen, Zahnpasta, Kosmetika, usw.

Dank Titandioxyd garantiert **Bios Self-Cleaning®** ausgezeichnete Leistungen und verleiht besonders als Fassadenverkleidung folgende Eigenschaften:

- Fotokatalytische Eigenschaften, die bei Lichteinfall die Zersetzung der organischen Stoffe und der auf der Fliesenoberfläche abgesetzten Schadstoffe ermöglichen und Eigenschaften der Selbstreinigung und Luftreinigung garantieren.
- Super hydrophile Eigenschaften, welche die selbstreinigende Fähigkeit zusätzlich betont. Je größer die UV-Bestrahlung der behandelten Oberfläche, umso kleiner wird ihr Kontaktwinkel mit dem Wasser, der nach einem vernünftigen Zeitintervall sogar zum Nullwert neigt. Das bedeutet, dass sich das Wasser leicht ausbreitet und spült.

Praktisch wird die Wirkung von Titandioxyd, das die organischen Ablagerungen an der behandelten Oberfläche zersetzt, dank der Fotokatalyse mit einer hydrophilen Wirkung bereichert, mit der das Regenwasser die Fliesen reinigen und die Flecken von den Oberflächen entfernen kann.



# bios self-cleaning®

## EFFICACIA DEL PROCESSO AUTOPULENTE

Le prestazioni autopulenti di Bios Self-Cleaning® sono estremamente efficaci e certificate, ma è importante sottolineare che:

- **NON** sono in grado di rimuovere completamente i depositi che eccedono la proprietà autopulente, quali macchie che aderiscono alle facciate rapidamente, massicciamente e tenacemente, come i sigillanti al silicone
- **NON** sono in grado di rimuovere ruggine ed efflorescenze
- **NON** si attiva il processo autopulente in assenza di pioggia ed esposizione ai raggi UV.

## EFFECTIVENESS OF THE SELF-CLEANING PROCESS

The self-cleaning property of Bios Self-Cleaning® is extremely effective and certified, but you should keep in mind that:

- **THEY CANNOT** remove all the stains that surpass their self-cleaning properties, such as stains that stick to the facing quickly, massively and stubbornly, e.g. silicone sealants.
- **THEY CANNOT** remove rust or crystals.
- **NO** self-cleaning process may take place without rain or exposure to UV rays.

Macchia organica 1 Organic stain 1 Tache organique 1 Organischer Fleck 1	Macchia organica 2 Organic stain 2 Tache organique 2 Organischer Fleck 2	Macchia non organica 1 Non organic stain 1 Tache non organique 1 Nicht organischer Fleck 1	Macchia non organica 2 Non organic stain 2 Tache non organique 2 Nicht organischer Fleck 2
Macchia oleosa, polvere e fuliggine, gas di scarico	Sigillante al silicone, graffiti, vernice, alveari, ragnatele	Sabbia, fango	Ruggine, efflorescenze, iridescenze
Greasy stain, dust and soot, exhaust gases	Silicone sealant, graffiti, paint, beehives, spider webs	Sand, mud	Rust, efflorescences, iridescent spots
Tache graisseuse, poussière et suie, gaz d'échappement	Colle silicone, graffitis, peinture, ruches, toiles d'araignée	Sable, boue	Rouille, efflorescences, irisations
Ölfleck, Staub und Russt, Abgas	Silikondichtmasse, Graffiti, Lack, Bienenstöcke, Spinnennetze	Sand, Schlamm	Rust, Ausblühungen, Irideszenzen



### EFFICACIA AUTOPULENTE DI BIOS SELF-CLEANING® SELF-CLEANING PROPERTY OF BIOS SELF-CLEANING® EFFICACITÉ AUTONETTOYANTE DE BIOS SELF-CLEANING® WIRKSAMKEIT DER SELBSTREINIGUNG VON BIOS SELF-CLEANING®

Efficace	Difficile da rimuovere completamente mediante l'effetto autopulente	Efficace	Non efficace
Effective	Cannot be completely removed by self-cleaning	Effective	Ineffective
Efficace	Difficile à éliminer complètement au moyen de l'action autonettoyante	Efficace	Non efficace
Wirksam	Schwierig komplett zu entfernen durch die selbstreinigende Wirkung	Wirksam	Unwirksam



## EFFICACITÉ DU PROCESSUS AUTONETTOYANT

*Quoique la capacité autonettoyante de Bios Self-Cleaning® soit extrêmement efficace, outre à être certifiée*, il convient de souligner que :

- son action **NE PEUT** éliminer totalement les dépôts allant au-delà de sa capacité autonettoyante, telles les taches qui adhèrent aux façades de manière rapide, massive et tenace, comme par exemple les colles silicone
- son action **NE PEUT** éliminer la rouille et les efflorescences
- le processus autonettoyant **NE PEUT S'ACTIVER** en absence de pluie et d'exposition aux rayons UV.

## WIRKSAMKEIT DES SELBSTREINIGUNGSPROZESSES

*Die selbstreinigenden Leistungen von Bios Self-Cleaning® sind extrem wirksam und zertifiziert*, doch Folgendes ist unbedingt zu unterstreichen:

- **NICHT** komplett entfernt werden Ablagerungen, welche die Selbstreinigungsfähigkeiten überschreiten, so z.B. Flecken, die rasch massiv und hartnäckig an Fassaden anhaften wie Silikondichtmassen.
- **NICHT** entfernt werden Rost und Ausblühungen
- **NICHT** aktiviert wird der Selbstreinigungsprozess ohne Regen und UV-Bestrahlung.

### Macchia organica 2

Organic stain 2

Tache organique 2

Organischer Fleck 2

*Perché sigillanti al silicone e graffiti sono difficili da rimuovere con l'effetto autopulente?*

*Why are silicone sealants and graffiti hard to remove by the self-cleaning reaction?*

*Pourquoi l'effet autonettoyant élimine-t-il difficilement les colles silicone et les graffitis?*

*Weshalb sind Silikondichtmassen und Graffiti mit der selbstreinigenden Wirkung schwer zu entfernen?*

La loro potente forza adesiva supera la proprietà autopulente di **Bios Self-Cleaning®**.

Inoltre, deviano i raggi UV dalla superficie delle piastrelle, pertanto è difficile che su tale superficie si generi l'ossigeno attivo.

Their powerful adhesive strength exceeds the self-cleaning power of **Bios Self-Cleaning®**.

In addition, they divert the UV rays from the tile surface, so active oxygen can hardly form on such surfaces.

Leur force d'adhésion très élevée est supérieure à la capacité autonettoyante de **Bios Self-Cleaning®**.

Par ailleurs, vu qu'ils dévient les rayons UV de la surface des carreaux, il est donc difficile que de l'oxygène actif puisse se former sur ce type de surface.

Ihr kräftiges Haftvermögen übertrifft die selbstreinigende Fähigkeit von **Bios Self-Cleaning®**.

Außerdem weisen sie die UV-Strahlen von der Fliesenoberfläche ab, sodass sich kaum Aktivsauerstoff auf ihnen bildet.

### Macchia non organica 2

Non organic stain 2

Tache non organique 2

Nicht organischer Fleck 2

*Perché ruggine ed efflorescenze NON vengono lavate via dall'effetto autopulente?*

*Why are rust and efflorescences NOT washed off by the self-cleaning reaction?*

*Pourquoi l'effet autonettoyant N'ÉLIMINE-T-IL ni la rouille ni les efflorescences ?*

*Weshalb werden Ausblühungen von der selbstreinigenden Wirkung NICHT weggespült?*

Se ruggine ed efflorescenze aderiscono alla superficie delle piastrelle grazie all'ausilio di sostanze intermedie quali macchie e depositi oleosi, **Bios Self-Cleaning®** è in grado di rimuoverle. Se invece aderiscono direttamente, le proprietà di decomposizione di Bios Self-Cleaning® NON sono efficaci su queste sostanze inorganiche.

If the rust and efflorescences are glued to the tile surface by such mediums as greasy stains or spots, then **Bios Self-Cleaning®** can remove them.

If they are directly stuck to the surface, then the decomposing properties of Bios Self-Cleaning® ARE NOT effective on such inorganic substances.

Si la rouille et les efflorescences adhèrent à la surface des carreaux au moyen de substances intermédiaires, comme par exemple par le biais de taches et de dépôts graisseux, **Bios Self-Cleaning®** est en mesure de les éliminer. En revanche, si ces substances adhèrent directement aux carreaux, les propriétés de décomposition de **Bios Self-Cleaning®** NE SONT PAS efficaces sur ces substances non organiques.

Wenn Rost und Ausblühungen mit Zwischenstoffen wie Flecken bzw. Ölablagerungen an der Fliesenoberfläche anhaften, kann **Bios Self-Cleaning®** sie entfernen. Haften sie dagegen direkt an, dann sind die Zersetzungsfähigkeiten von Bios Self-Cleaning® auf solchen anorganischen Stoffen unwirksam.

# bios self-cleaning®

## L'ABBATTIMENTO DEGLI AGENTI INQUINANTI E LA PURIFICAZIONE DELL'ARIA

Una delle principali cause di inquinamento dell'atmosfera, che minaccia concretamente la salute dell'uomo e dell'ambiente, è costituita dai NOx (ossidi di azoto sottoprodotti dei processi di combustione), generati dagli automezzi, dal riscaldamento domestico e da alcuni processi industriali.

L'ossigeno attivo ( $-OH$ ,  $O_2^-$ ) prodotto dagli involucri di facciata rivestiti con **Bios Self-Cleaning®** ossida i NOx in sostanze non nocive ( $NO_3^-$  nitrato solubile in acqua), che vengono rimosse attraverso il dilavamento dell'acqua piovana. Grazie alla loro scarsa quantità, i  $NO_3^-$  ossidati dalla reazione fotocatalitica non hanno alcuna influenza sull'acidificazione del suolo.

Le prestazioni di abbattimento dei NOx garantite da **Bios Self-Cleaning®** offrono un apprezzabile contributo al miglioramento della qualità ambientale degli insediamenti urbani. Basti pensare che un rivestimento di 1000 metri quadrati di facciata con **Bios Self-Cleaning®** ha la capacità di purificare l'aria in misura paragonabile a un bosco delle dimensioni di un campo da calcio, oppure di eliminare gli ossidi di azoto (NOx) emessi da 70 automobili nel corso di un'intera giornata.

## POLLUTANT-REDUCTION AND AIR-CLEANSING PROPERTIES

One of the main sources of atmospheric pollution, which really threatens human and environmental health, are NOx (nitrogen oxides as combustion by-products) from vehicles, heating and some industrial processes.

The active oxygen ( $-OH$ ,  $O_2^-$ ) produced by the **Bios Self-Cleaning®** facings oxidises the NOx into non-harmful substances ( $NO_3^-$  water-soluble nitrate), which are washed off by rainwater. The  $NO_3^-$  oxidised by the photo-catalytic reaction is too little to have any influence on soil acidification.

The guaranteed NOx-reducing properties of **Bios Self-Cleaning®** make an appreciable contribution to the improvement of the environmental standards of urban settlements. Just think that a 1000 sqmt **Bios Self-Cleaning®** facing can purify the air like a wood the size of a football pitch or remove the nitrogen oxides (NOx) emitted by 70 cars during one day.

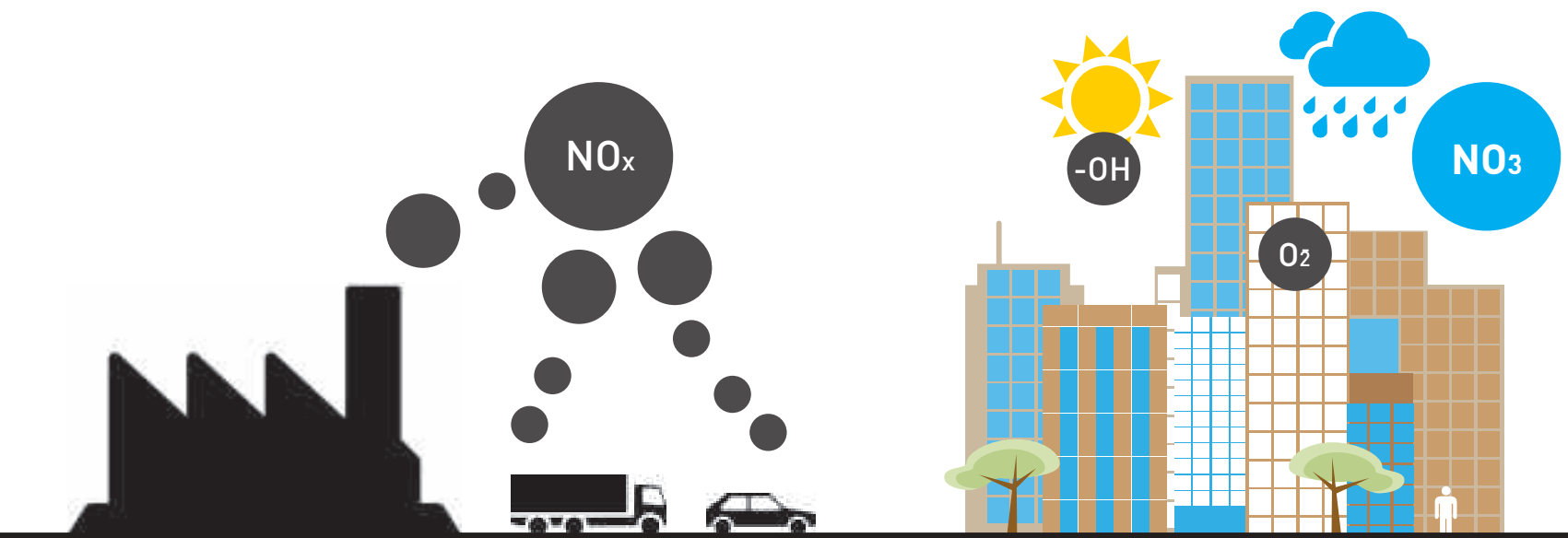

## ABATTEMENT DES AGENTS POLLUANTS ET PURIFICATION DE L'AIR

Une des principales causes de la pollution de l'air, qui par ailleurs menace concrètement la santé de l'homme et l'environnement, est représentée par les NOx (oxydes d'azote, sous-produits du processus de combustion) émis par les véhicules, le chauffage domestique et certains processus industriels. L'oxygène actif ( $-OH$ ,  $O_2^-$ ) généré par les façades revêtues des produits **Bios Self-Cleaning®**, oxyde les NOx en substances non nocives ( $NO_3^-$  nitrate hydrosoluble) qui sont ensuite éliminés par l'eau de pluie. Grâce à leur faible quantité, les  $NO_3^-$  oxydés par la réaction photocatalytique n'ont aucune incidence sur l'acidification du sol.

La capacité d'abattement des NOx effectuée par **Bios Self-Cleaning®** offre une contribution appréciable à l'amélioration de la qualité de l'environnement des centres urbains.

Il suffit de penser qu'une façade de 1000 m<sup>2</sup> revêtue de **Bios Self-Cleaning®** a une capacité de purifier l'air comparable à celle d'une forêt de la taille d'un terrain de football, ou d'éliminer les oxydes d'azote (NOx) émis pendant 24 heures par 70 véhicules.

## DER ABBAU DER SCHADSTOFFE UND DIE REINIGUNG DER LUFT

Eine der Hauptursachen der Luftverschmutzung, die unsere Gesundheit und unsere Umgebung konkret bedrohen, sind die NOx (Stickstoffoxyde als Nebenprodukte des Verbrennungsprozesses), die von Fahrzeugen, Raumheizungen und einigen Industrieverfahren erzeugt werden. Der von mit **Bios Self-Cleaning®** verkleideten Fassaden erzeugte Aktivsauerstoff ( $-OH$ ,  $O_2^-$ ) oxydiert die NOx in unschädliche Stoffe ( $NO_3^-$  wasserlösliches Nitrat), die durch Auswaschung mit Regenwasser entfernt werden. Dank ihrer geringen Menge haben durch fotokatalytische Reaktion oxydierten  $NO_3^-$  keinerlei Einfluss auf die Bodensäuerung. Die von **Bios Self-Cleaning®** garantierten NOx-Abbauleistungen bieten einen schätzenswerten Beitrag zur Verbesserung der Qualität der Umwelt in Wohngebieten. Man denke allein schon daran, dass eine 1000 Quadratmeter große mit **Bios Self-Cleaning®** verkleidete Fassade die Fähigkeit besitzt, die Luft in einem Ausmaß zu reinigen, das mit einem Wald in der Größe eines Fußballplatzes vergleichbar ist, oder die Stickstoffoxyde (NOx) zu beseitigen, die von 70 Autos im Laufe eines ganzen Tages freigesetzt werden.

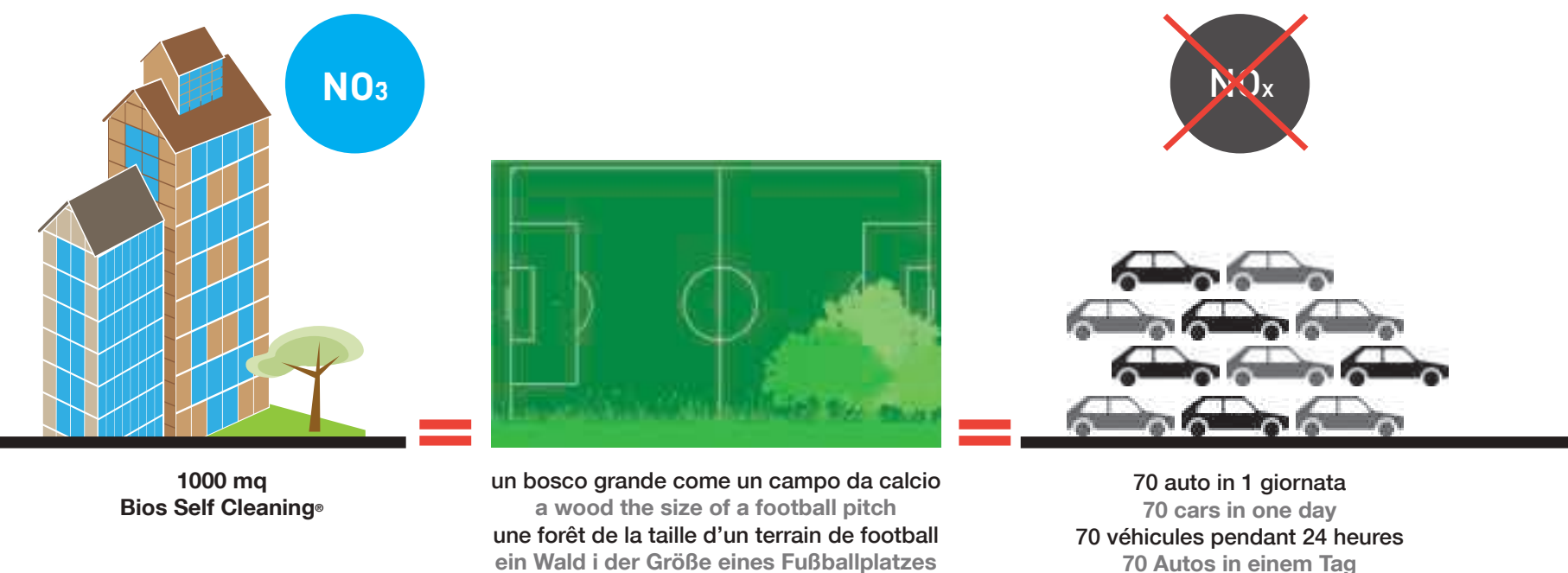

# bios self-cleaning®

## DURATA DELLE PRESTAZIONI

Grazie a una severa serie di prove di laboratorio è stato possibile dimostrare che le prestazioni di **Bios Self-Cleaning®** non si riducono nel tempo. La durabilità è stata confermata sottoponendo le lastre ceramiche a un test d'invecchiamento accelerato in condizioni equiparabili a 50 anni di esposizione all'esterno. Per quanto concerne la resistenza al calpestio, va evidenziato come la tecnologia HYDROTECT®, inglobata a caldo sulla superficie di **Bios Self-Cleaning®** durante il ciclo di produzione industrializzata, sia in grado di assicurare nel tempo le sue caratteristiche rispettando le prescrizioni relative alle sollecitazioni da traffico leggero e le relative avvertenze di manutenzione.

## CERTIFICAZIONI

Le prestazioni della tecnologia HYDROTECT®, con cui sono trattate le lastre ceramiche in grès porcellanato **Bios Self-Cleaning®**, sono certificate secondo le più importanti norme internazionali.

## LONG-TERM EFFICIENCY

A number of strict lab tests proved that the efficiency of **Bios Self-Cleaning®** does not diminish over time. The durability of the ceramic slabs has been confirmed by an accelerated aging test, the conditions of which were comparable to 50 years' outdoor exposure. Note that in heavy-traffic areas, the HYDROTECT® technology, if hot embedded in the **Bios Self-Cleaning®** surface during the industrial production process, will perform well over time and will fulfil the applicable light traffic resistance and maintenance requirements.

## CASALGRANDE PADANA'S PRODUCT RANGES

The performance of the HYDROTECT® technology, applied to **Bios Self-Cleaning®** unglazed stoneware ceramic slabs, is certified according to the most important international standards.

## DURÉE DES TRAITEMENTS

Les nombreux essais rigoureux menés en laboratoire ont permis de démontrer la très longue durée de vie des propriétés de **Bios Self-Cleaning®**. Cette durabilité a été confirmée en faisant subir des tests de vieillissement accéléré aux dalles céramiques, ceci à des conditions comparables à 50 ans d'exposition aux agents atmosphériques.

En ce qui concerne la résistance au bruit d'impact, il faut souligner que la technologie HYDROTECT®, englobée à chaud sur la surface de **Bios Self-Cleaning®** pendant le cycle de fabrication, est en mesure de garantir longuement ses caractéristiques, en respectant les prescriptions sur les sollicitations dérivant d'un trafic léger et les règles d'entretien correspondantes.

## CERTIFICATIONS

Les propriétés de la technologie HYDROTECT®, qui caractérisent les dalles céramiques en grès cérame **Bios Self-Cleaning®**, sont certifiées selon les plus importantes normes internationales.

## DAUERHAFTIGKEIT DER LEISTUNGEN

Dank einer Reihe strenger Labortests konnte nachgewiesen werden, dass die Leistungen von **Bios Self-Cleaning®** im Laufe der Zeit nicht nachlassen. Die Dauerhaftigkeit wurde bestätigt, indem die Keramikplatten einem beschleunigten Alterungstest unter Verhältnissen ausgesetzt wurden, die mit einer 50jährigen Exposition im Freien vergleichbar sind. Was die Begehungsfestigkeit betrifft, ist zu sagen, dass die während des industriellen Produktionsprozesses warm in die Oberfläche von **Bios Self-Cleaning®** eingearbeitete HYDROTECT® Technologie in der Lage ist, ihre Leistungen dauerhaft zu sichern und die Vorschriften für leichte Verkehrsbeanspruchungen und die entsprechenden Instandhaltungshinweise einzuhalten.

## ZERTIFIZIERUNGEN

Die Leistungen der HYDROTECT® Technologie, mit der die Keramikplatten aus **Bios Self-Cleaning®** Feinsteinzeug behandelt werden, sind nach den wichtigsten internationalen Normen zertifiziert.



**bios unicolore iperbianco** cm 60x120 - 23<sup>5</sup>/<sub>8</sub>"x47<sup>7</sup>/<sub>8</sub>"

# bios antibacterial®

**Bios Antibacterial®** è la linea di pavimenti e rivestimenti in gres porcellanato, conforme al Regolamento Europeo sui Biocidi (EU BPR 528/2012)\* capaci di abbattere al 99,9% i quattro principali ceppi batterici presenti sulle superfici: *Staphylococcus aureus*, *Escherichia coli*, *Pseudomonas aeruginosa*, *Enterococcus faecalis*.

La tecnologia di **Bios Antibacterial®** sfrutta le caratteristiche dell'argento, materiale nobile ampiamente utilizzato nella produzione di oggetti d'uso quotidiano (posate, teiere, monete, monili), le cui proprietà antibatteriche sono note sin dall'antichità.

Un materiale assolutamente innocuo per la salute, anallergico a contatto con la pelle, che non rilascia sostanze nocive.

**Bios Antibacterial®** è attivo sempre, in qualsiasi condizione di luce, anche al buio assoluto.



\* Il regolamento BPR sui biocidi concerne l'immissione sul mercato e l'uso di biocidi, utilizzati per la tutela dell'uomo, degli animali, dei materiali o degli articoli contro organismi nocivi, quali parassiti o batteri, mediante l'azione dei principi attivi contenuti nel biocida.

Il testo è stato adottato il 22 maggio 2012 ed è applicato dal 1 settembre 2013. Secondo il regolamento BPR in vigore i prodotti antibatterici che non sono conformi alla regolamentazione in esso contenuta non possono essere immessi nel mercato europeo.

**Bios Antibacterial®** is the range of porcelain stoneware floorings and coverings, compliant with the European Biocidal Products Regulation (EU BPR 528/2012)\*, able to remove up to 99.9% of the main strains of bacteria present on surfaces: *Staphylococcus aureus*, *Escherichia coli*, *Pseudomonas aeruginosa* and *Enterococcus faecalis*.

**Bios Antibacterial®** uses the characteristics of silver, a noble material widely employed in the production of everyday objects (cutlery, teapots, coins, jewellery), and known since ancient times for its antibacterial properties.

The material is entirely harmless to health, non-allergenic in contact with the skin and does not release harmful substances.

**Bios Antibacterial®** is always active, whatever the light conditions, even in complete darkness.



\* The BPR regulation on biocidal products concerns the making available on the market and the use of biocidal products, used to protect humans, animals, materials or objects from harmful organisms, such as pests or bacteria, by means of the active substances contained in the biocidal products.

The text was adopted on 22 May 2012 and applied from 1 Sept. 2013. According to the BPR regulation in force, antibacterial products that do not comply with the standards contained therein cannot be placed on the European market.

**Bios Antibacterial®** est la ligne de revêtements de sol et de mur en grès cérame, conformes au règlement européen sur les produits biocides (EU BPR 528/2012)\*, capables d'éliminer à 99,9 % les principales souches bactériennes présentes sur les surfaces : *Staphylococcus aureus*, *Escherichia coli*, *Pseudomonas aeruginosa*, *Enterococcus faecalis*.

La technologie de **Bios Antibacterial®** exploite les caractéristiques de l'argent, matériau noble largement utilisé pour produire des objets d'usage quotidien (couverts, théières, monnaies, bijoux), dont les propriétés antibactériennes sont connues depuis l'Antiquité.

Il s'agit d'un matériau totalement inoffensif pour la santé, anallergique au contact avec la peau et qui ne libère aucune substance nocive.

**Bios Antibacterial®** est toujours actif, dans toutes les conditions de luminosité, y compris dans la nuit complète.



\* Le règlement sur les produits biocides (RPB) concerne la mise sur le marché et l'utilisation des produits biocides, qui sont utilisés pour protéger l'homme, les animaux, les matériaux ou les articles contre les organismes nuisibles, tels que les parasites et les bactéries, par l'action des substances actives contenues dans le produit biocide.

Le texte a été adopté le 22 mai 2012 et est appliqué depuis le 1er septembre 2013. Selon le règlement RPB en vigueur, les produits antibactériens qui ne sont pas conformes à la réglementation contenue dans celui-ci ne peuvent être introduits sur le marché européen.

**Bios Antibacterial®** ist die Produktlinie von Boden- und Wandverkleidungen aus Feinsteinzeug in Übereinstimmung mit der Europäischen Biozid-Verordnung (EU BPR 528/2012)\*, die 99,9 % der vier wichtigsten Bakterienstämme auf Oberflächen abtöten kann: *Staphylococcus aureus*, *Escherichia coli*, *Pseudomonas aeruginosa* und *Enterococcus faecalis*.

Die Technologie **Bios Antibacterial®** nutzt die Eigenschaften von Silber, einem edlen Material, das bei der Herstellung von Alltagsgegenständen (Besteck, Teekannen, Münzen, Schmuck) weit verbreitet ist und dessen antibakterielle Eigenschaften seit der Antike bekannt sind.

Es ist ein gesundheitlich absolut unbedenkliches Material, das bei Kontakt mit der Haut hypoallergen ist und keine schädlichen Stoffe freisetzt.

**Bios Antibacterial®** ist bei allen Lichtverhältnissen – selbst bei völliger Dunkelheit – jederzeit wirksam.



\* Die BPR-Verordnung über Biozidprodukte betrifft das Inverkehrbringen und die Verwendung von Biozidprodukten, die zum Schutz von Menschen, Tieren, Materialien oder Gegenständen vor schädlichen Organismen wie Parasiten oder Bakterien durch die Wirkung der im Biozidprodukt enthaltenen Wirkstoffe verwendet werden.

Der Text wurde am 22. Mai 2012 verabschiedet und ab 1. September 2013 findet er Anwendung. Nach der geltenden BPR-Verordnung dürfen antibakterielle Produkte, die nicht mit den in der Verordnung enthaltenen Vorschriften übereinstimmen, nicht auf den europäischen Markt gebracht werden.

## CAUSE ED EFFETTI DEI BATTERI NEGLI AMBIENTI

Lo *Staphylococcus aureus*, l'*Escherichia coli*, lo *Pseudomonas aeruginosa* e l'*Enterococcus faecalis*, sono i principali responsabili delle infezioni che si registrano in ambito ospedaliero e sono stati adottati come indicatori standard perché rappresentano la categoria più aggressiva, in alcuni casi super resistente anche agli antibiotici.

### Quando un prodotto può definirsi antibatterico

Dopo severe prove di laboratorio, *Bios Antibacterial®* è risultato altamente efficace, in quanto capace di abbattere del 99,9% i quattro principali ceppi batterici presenti negli ambienti confinati: *Staphylococcus aureus*, *Enterococcus faecalis*, *Escherichia coli*, *Pseudomonas aeruginosa*.

Nella pratica il 100% di antibattericità non può essere assicurato, la soglia di efficacia è stata quindi fissata dai ricercatori di tutto il mondo a oltre il 90%, perché solo a questi livelli si può registrare una riduzione realmente significativa dei batteri. Per questo motivo, in termini di efficacia antibatterica, la comunità scientifica non prende in considerazione valori inferiori alla soglia del 90% e i prodotti che non raggiungono questo livello non possono essere definiti antibatterici. La ricerca ha inoltre evidenziato che *Bios Antibacterial®* in presenza di umidità, tradizionale terreno fertile per lo sviluppo della flora batterica, vede addirittura amplificare i propri effetti benefici. Va comunque evidenziato come la tecnologia *Bios Antibacterial®*, pur essendo capace di abbattere al 99,9% i 4 principali ceppi batterici presenti negli ambienti e ridurre la crescita virale, non possa garantire in assoluto l'immunità da infezioni. Si consiglia pertanto, in funzione delle specifiche destinazioni d'uso degli ambienti, di sottoporre le superfici ad appropriati cicli di pulizia e disinfezione.

## LE PROPRIETÀ ANTIODORE

I cattivi odori sono tra le cause più invalidanti della qualità degli ambienti, oltre che segnale tangibile di bassi livelli di igiene dell'aria e delle superfici. Nei locali bagno i cattivi odori vengono generati dalla combinazione tra urea, germi e batteri, che producono ammoniaca e trimetilammina. Effetti analoghi possono attivarsi nelle cucine, causati dalla reazione con microresidui organici. Inoltre, sempre nei bagni e a bordo piscina la concentrazione di sebo e residui cutanei, in combinazione con i germi, dà luogo alla formazione di macchie e depositi viscosi che, oltre al degrado nell'aspetto dei rivestimenti, possono ridurre le caratteristiche antiderapanti delle superfici e la sicurezza al calpestio. In tutti questi casi, l'effetto antibatterico di *Bios Antibacterial®*, aiuta a eliminare i cattivi odori e a mantenere valide le caratteristiche antiderapanti delle piastrelle anche in assenza totale di luce, offrendo garanzie nel più ampio spettro.

## CAUSES AND EFFECTS OF BACTERIA IN THE ENVIRONMENT

*Staphylococcus aureus*, *Escherichia coli*, *Pseudomonas aeruginosa* and *Enterococcus faecalis* are largely responsible for hospital-acquired infections and have been taken as standard indicators, because they are the most aggressive class of bacteria, which sometimes can even be resistant to antibiotics.

### When a product can be called antibacterial

After strict lab tests, *Bios Antibacterial®* turned out to be extremely effective, as it can remove 99.9% of the main four bacterial strains living in confined areas: *Staphylococcus aureus*, *Enterococcus faecalis*, *Escherichia coli*, *Pseudomonas aeruginosa*.

As a matter of fact, a 100% anti-bacterial effect cannot be ensured, so the effectiveness threshold has been set by researchers all over the world at over 90%, because only at such levels can a really significant reduction in bacteria be measured. That's why in terms of antibacterial effectiveness the scientific community will not take into account any rating under 90% and products that fail to achieve such level may not be called antibacterial. In addition, research has shown that *Bios Antibacterial®* needs no light to be activated, and in a humid environment, which is traditionally a fertile ground for the growth of bacterial flora, its beneficial effects are even greater. Note, however, that, even if capable of removing 99.9% of the 4 main bacterial strains living in the environment and reducing viral growth, the *Bios Antibacterial®* technology cannot ensure perfect immunity to infections. Therefore, depending on the way a place is to be used, the surfaces should be treated with appropriate cleaning and disinfection procedures.

## DEODORISING PROPERTIES

Bad smells are some of the factors that most deteriorate the quality of an environment, as well as being a tangible sign of a low level of air and surface hygiene. In bathrooms, bad smells are generated by a combination of urea, germs and bacteria that produce ammonia and trimethylamine. Similar effects may be had in kitchens as a reaction with organic micro-residues. In addition, also in bathrooms or poolside, a concentration of sebum and shed skin cells, combined with germs, forms stains and slippery spots that, as well as deteriorating the appearance of a facing, may reduce the anti-slipping properties of the surfaces and their safety when walked over. In all these cases, the antibacterial effect of *Bios Antibacterial®* helps remove bad smells and retain the anti-slipping properties of the tiles even without any light, for perfect safety.

# bios antibacterial®

## CAUSES ET EFFETS DES BACTÉRIES DANS LE MILIEU AMBIANT

Le Staphylococcus aureus, l'Escherichia coli, le Pseudomonas aeruginosa et l'Enterococcus faecalis sont les principaux responsables des infections enregistrées en milieu hospitalier.

Ils ont été adoptés comme indicateurs standard car ce sont les souches les plus agressives, dans certains cas même résistantes aux antibiotiques.

## Quand un produit peut être défini comme antibactérien ?

Après de rigoureux essais en laboratoire, **Bios Antibacterial®** résulte extrêmement efficace, étant capable d'abattre 99,9% des quatre principales souches bactériennes présentes dans les espaces fermés : Staphylococcus aureus, Enterococcus faecalis, Escherichia coli, Pseudomonas aeruginosa.

Dans la pratique, étant difficile d'assurer des propriétés 100% antibactéricides, la communauté scientifique mondiale a fixé le seuil d'efficacité à plus de 90%, car c'est seulement à ce niveau que l'on peut enregistrer une réduction vraiment significative des bactéries.

Pour cette raison, il faut souligner qu'en termes d'efficacité antibactérienne, la communauté scientifique ne prend même pas en considération les valeurs inférieures à 90%, et donc les produits qui n'atteignent pas cette limite ne peuvent en aucun cas être définis comme antibactériens.

La recherche a également montré que **Bios Antibacterial®** n'a pas besoin de lumière pour s'activer, et qu'en présence d'humidité,

facteur propice au développement de la flore bactérienne, ses effets bénéfiques augmentent ultérieurement. Il faut souligner que même si la technologie **Bios Antibacterial®** est capable d'abattre 99,9% des 4 principales souches bactériennes et de réduire leur croissance, elle ne peut toutefois garantir une immunité totale contre les infections. Il est donc conseillé, en fonction de chaque contexte d'utilisation spécifique, de soumettre les surfaces à des cycles de nettoyage et de désinfection adéquats.

## LES PROPRIÉTÉS ANTI-ODEURS

Les mauvaises odeurs sont une des causes qui nuisent le plus à la qualité de l'air et sont aussi le signe tangible du bas niveau d'hygiène de l'air et des surfaces.

Dans les salles de bains, les mauvaises odeurs sont générées par la combinaison entre l'urée, les germes et les bactéries, qui produisent de l'ammoniac et de la triméthylamine.

Des effets analogues peuvent se produire en cuisine, dus à la réaction avec des micro résidus organiques.

Par ailleurs, en salle de bains ou sur le bord des piscines, la concentration de sébum et de résidus cutanés, en combinaison aux germes, donne lieu à la formation de taches et de dépôts visqueux, qui outre à dégrader l'aspect des revêtements, peuvent réduire les caractéristiques antiglisse des surfaces, et donc la sécurité des personnes. L'effet antibactérien de **Bios Antibacterial®** aide toujours à éliminer les mauvaises odeurs et à préserver les caractéristiques anti-glisse des carreaux, même en l'absence totale de lumière, en offrant des garanties à large spectre.



Emergency Salam  
Surgery Centre di Khartoum



## URSACHEN UND AUSWIRKUNGEN VON BAKTERIEN IN RÄUMEN

Die *Staphylococcus aureus*, *Escherichia coli*, *Pseudomonas aeruginosa* und *Enterococcus faecalis* sind die Hauptverantwortlichen der Infektionen, die sich in Krankenhausbereichen ereignen und wurden als Standard-Anzeiger übernommen, da sie die aggressivste Kategorie darstellen, die in einigen Fällen sogar gegen Antibiotika resistent ist.

### Wann kann ein Produkt als antibakteriell bezeichnet werden

Nach strengen Labortests hat sich *Bios Antibacterial*<sup>®</sup> als höchst wirksam erwiesen, da das Produkt die vier in angrenzenden Bereichen vorhandenen wichtigsten Bakterienstämme zu 99,9% abbaut: *Staphylococcus aureus*, *Enterococcus faecalis*, *Escherichia coli*, *Pseudomonas aeruginosa*.

In der Praxis kann eine zu 100% bakterientötende Wirkung nicht zugesichert werden, sodass die Wirksamkeitsschwelle von den Forschern aller Welt auf über 90% festgelegt wurde, denn nur in diesem Ausmaß kann eine wirklich bedeutende Reduzierung der Bakterien festgestellt werden. Aus diesem Grund berücksichtigt die wissenschaftliche Gemeinschaft in Hinsicht auf die antibakterielle Wirksamkeit keine Werte unter 90% und Produkte, die dieses Niveau nicht erreichen, können nicht als antibakteriell bezeichnet werden. Die Forschung hat außerdem festgestellt, *Bios Antibacterial*<sup>®</sup> kein Licht benötigt, um aktiv zu werden und bei Feuchtigkeit, einem bekanntlich begünstigenden Zustand für die Entwicklung von Bakterienflora, die vorteilhaften Wirkungen sogar noch verstärkt. Es ist auf jeden Fall zu

sagen, dass die Technologie *Bios Antibacterial*<sup>®</sup> trotz ihrer Fähigkeit, die 4 wichtigsten in der Umgebung vorhandenen Bakterienstämme zu 99,9% abzubauen und die Virenwucherung zu reduzieren, die Immunität gegenüber Infektionen nicht absolut garantieren kann. Deshalb wird empfohlen, auf den Oberflächen in Funktion der spezifischen Einsatzbedingungen der Räume angemessenen Reinigungs- und Desinfektionszyklen vorzunehmen.

### DIE GERUCHHEMMENDEN EIGENSCHAFTEN

Schlechte Gerüche gehören zu den Ursachen, die der Qualität der Räume am meisten schaden und sind außerdem ein offensichtliches Zeichen geringer Hygieneniveaus in der Luft und auf den Flächen. Im Badezimmer werden schlechte Gerüche von der Kombination zwischen Urin, Keimen und Bakterien verursacht, die Ammoniak und Trimethylamin erzeugen. Gleiche Folgen können sich in Küchen durch die Reaktion mit organischen Mikrorückständen ergeben. Außerdem bilden sich in Badezimmern und an Schwimmbadrandern durch die Konzentration von Hauttalg und Hautrückständen in Kombination mit Keimen Flecken und schlüpfrige Ablagerungen, die nicht nur die Auskleidungen unschön machen, sondern auch die rutschhemmenden Eigenschaften der Oberflächen und die Trittsicherheit reduzieren. In allen diesen Fällen hilft die antibakterielle Wirkung von *Bios Antibacterial*<sup>®</sup>, die schlechten Gerüche zu beseitigen und die rutschhemmenden Eigenschaften der Fliesen zu bewahren, auch ganz ohne Licht und bietet deshalb eine Garantie in einem ganz breiten Spektrum.



# bios antibacterial®

## STAPHYLOCOCCUS AUREUS

Lo Staphylococcus aureus è un batterio Gram positivo di forma sferica. Il suo sviluppo ha luogo fra 10°C e 45°C con un optimum di temperatura compreso tra i 30°C e i 37°C; per quanto riguarda il pH, fra 4 e 9 con un optimum fra 7 e 7,5. Pur non essendo sporigeni gli stafilococchi mostrano una notevole resistenza a condizioni ambientali sfavorevoli. È diffuso in generale nell'acqua, sulla pelle e nelle mucose. Introdotto nel nostro organismo, può generare infezioni di varia natura. Le infezioni da Staphylococcus aureus acquisite in ambiente ospedaliero in genere sono causate da stipti resistenti a vari chemioterapici e si manifestano sovente in forma epidemica. L'insorgere di queste epidemie in particolari reparti può rappresentare un evento di particolare gravità che pone seri problemi profilattici e terapeutici.

Staphylococcus is a spherical-shaped Gram-positive bacterium. It develops at a temperature of 10°C to 45°C, with optimum temperature being 30°C to 37°C; pH must be 4 to 9, with optimum pH being 7 to 7.5. Even if not sporogenic, staphylococci are extremely resistant to unfavourable environmental conditions. Usually widespread in water, skin and mucous membranes. If it enters our organism, it can induce a wide range of infections. Hospital-acquired infections with Staphylococcus aureus are usually caused by chemotherapeutic-resistant cells and often come in the form of veritable epidemics. In some wards, the outbreak of such epidemics may be an extremely challenging event that may raise serious prophylactic and therapeutic problems.

Le Staphylococcus aureus est une bactérie de forme sphérique à Gram positif. Son développement a lieu entre 10 °C et 45 °C avec une température optimale comprise entre 30 °C et 37 °C ; en ce qui concerne le pH, il se multiplie à un pH entre 4 et 9, le pH optimal étant compris entre 7 et 7,5. Bien qu'il ne s'agisse pas d'un microorganisme sporogène, le staphylocoque présente une résistance remarquable aux conditions ambiantes défavorables. On le trouve surtout dans l'eau, sur la peau et les muqueuses. Une fois dans notre organisme, il peut causer différents types d'infection. En milieu hospitalier, les infections à Staphylococcus aureus sont généralement causées par des souches résistantes à différentes substances chimiothérapeutiques et elles se manifestent souvent sous forme épidémique. L'apparition de ce type d'épidémie dans certains services hospitaliers peut constituer un événement extrêmement grave qui pose de sérieux problèmes prophylactiques et thérapeutiques.

Staphylococcus aureus ist ein gram-positives kugelförmiges Bakterium. Es entwickelt sich zwischen 10°C und 45°C, die optimalen Temperaturverhältnisse liegen zwischen 30°C und 37°C. Der pH-Wert liegt zwischen 4 und 9, optimal zwischen 7 und 7,5. Obwohl sie nicht sporogen sind, sind Staphylokokken unter ungünstigen Umgebungsverhältnissen besonders resistent. Das Bakterium ist generell im Wasser, auf der Haut und in den Schleimhäuten zu finden. Im menschlichen Organismus kann das Bakterium Infektionen verschiedener Art verursachen. In Krankenhausbereichen durch Staphylococcus aureus zu-

gezoogene Infektionen werden normalerweise von Stammzellen verursacht, die gegen verschiedene Chemotherapien resistent sind, und offenbaren sich häufig in epidemischer Form. Das Auftreten solcher Epidemien in bestimmten Abteilungen kann besonders schlimm sein und schwere prophylaktische und therapeutische Probleme hervorrufen.

## ESCHERICHIA COLI

Escherichia coli è una specie che fa parte della famiglia delle Enterobacteriaceae, microrganismi Gram negativi ubiquitari che si trovano nel suolo, nell'acqua, nella vegetazione e fanno parte della flora intestinale della maggior parte degli animali compreso l'uomo. La sua coltura è molto facile con una grande tolleranza di variazione del pH, con un optimum di 7,5. La temperatura ottimale è 37°C. Resiste bene al calore: incubato a 45°C.

L'Escherichia coli è un ospite normale dell'organismo umano in cui rappresenta la specie predominante della comunità batterica facoltativa residente nell'intestino crasso; per questo motivo la sua presenza in un dato materiale (ad es. acqua) può essere considerata un indizio sicuro di una contaminazione fecale.

Escherichia coli is a species of the family Enterobacteriaceae, ubiquitous Gram-negative micro-organisms that can be found in soil, water, vegetation and live in the gut flora of most animals, including humans. Cultures of Escherichia coli are very easy to make, as they tolerate a wide range of pH, with optimum pH being 7.5. Optimum temperature is 37°C. They resist quite well to incubated heat at 45°C. Escherichia coli is a normal host of human organism, in which it is the prevalent species of the facultative bacterial community living in the large intestine; that's why finding it in a given material (e.g. water) may be regarded as certain evidence of faecal contamination.

L'Escherichia coli, bacille appartenant à la famille des Enterobacteriaceae, est un microorganisme ubiquitaire à Gram négatif. On le trouve dans l'eau, le sol et la végétation, et il fait partie de la flore intestinale de la plupart des animaux, y compris de l'être humain. Sa culture est très facile avec une grande tolérance de variation de pH, le pH optimal étant 7,5. Sa température optimale est de 37 °C. Incubé à 45 °C, ce bacille résiste à la chaleur. L'Escherichia coli est une bactérie commensale prédominante de la flore aérobie facultative du gros intestin ; pour cette raison, sa présence dans un milieu donné (l'eau, par exemple) est un indice sûr de contamination fécale.

Escherichia coli ist eine Spezies, die zur Familie der Enterobacteriaceae gehört, ubiquitäre gram-negative Mikroorganismen, die sich im Erdreich, im Wasser und in der Vegetation befinden und zur Darmflora der meisten Tiere und auch der Menschen gehören. Die Fortpflanzung erfolgt sehr leicht, mit großer pH-Variationstoleranz, optimal mit einem pH-Wert von 7,5. Die optimale Temperatur liegt bei 37°C.



Staphylococcus aureus



Escherichia coli



Pseudomonas aeruginosa

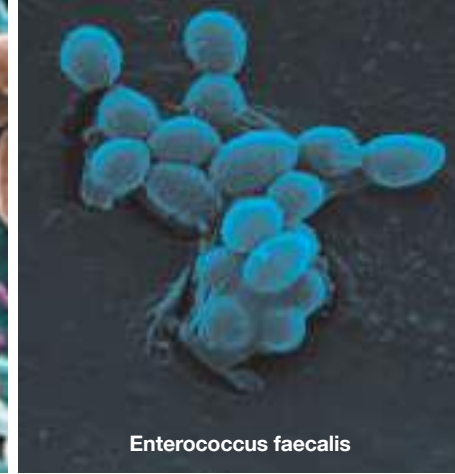

Enterococcus faecalis

Das Bakterium ist sehr wärmebeständig: Inkubation bei 45°C. Das Escherichia coli ist ein üblicher Gast des menschlichen Organismus, wo es die dominierende Species der im Dickdarm residenten fakultativen Bakteriengemeinschaft darstellt; deshalb ist seine Anwesenheit in einem bestimmten Material (z.B. Wasser) ein sicherer Hinweis auf eine fäkale Kontamination.

## PSEUDOMONAS AERUGINOSA

Pseudomonas aeruginosa è un batterio Gram negativo, capace di crescere a temperature comprese fra un minimo di 4°C e di un massimo di 42°C, ma non di svilupparsi al di sotto di pH 4.5. È un microorganismo molto presente nelle acque, nel suolo e come commensale sulla cute e nell'intestino. La sua scarsa o nulla sensibilità ai più comuni antibiotici fa sì che il suo sviluppo venga favorito da un qualsiasi trattamento con medicinali antibatterici: l'azione dell'antibiotico, infatti, riducendo la concorrenza della restante popolazione microbica, permette al batterio di raggiungere consistenze numeriche altrimenti impossibili.

Pseudomonas aeruginosa is a Gram-negative bacterium, which can grow at a temperature of 4°C up to 42°C, but will not develop if pH is less than 4.5. It is a micro-organism that can be often found in water, soil and as a commensal on skin or guts. Because of its poor or no sensitivity to the most common antibiotics, its growth is boosted by any antibacterial drug: actually, by reducing the competition of the rest of the microbial population, the effect of the antibiotic enables the bacterium to grow in numbers that would otherwise be impossible.

Pseudomonas aeruginosa est une bactérie à Gram négatif, capable de se développer à une température comprise entre un minimum de 4 °C et un maximum de 42 °C, mais incapable de se développer à un pH inférieur à 4.5. Surtout présent dans l'eau et le sol, ce microorganisme est une bactérie commensale de la peau et de l'intestin. Sa sensibilité, faible ou quasi nulle, aux antibiotiques les plus courants, fait que son développement est favorisé par de nombreux traitements à base de traitements antibactériens : en effet, l'action de l'antibiotique, en réduisant la concurrence de la population microbienne restante, permet à la bactérie d'atteindre une consistance numérique qui serait sinon impossible.

Pseudomonas aeruginosa ist ein gram-negatives Bakterium, das bei Temperaturen zwischen mindestens 4°C und maximal 42°C wachsen kann, sich bei pH-Werten unter 4.5 jedoch nicht entwickelt. Dieser Mikroorganismus ist stark vertreten in Gewässern, im Erdboden und als Kommensale auf der Haut und im Darm. Durch seine geringe oder fehlende Empfindlichkeit gegenüber den herkömmlichen Antibiotika wird seine Entwicklung bei irgendwelchen Behandlungen mit antibakteriellen Medikamenten gefördert: Die Wirkung des Antibiotikums erlaubt es dem Bakterium durch die Reduzierung der Konkurrenz der restlichen mikrobiellen Population tatsächlich, eine sonst nicht mögliche numerische Konsistenz zu erreichen.

## ENTEROCOCCUS FAECALIS

Gli enterococchi sono batteri Gram positivi molto diffusi in natura. Fanno parte della normale flora microbica intestinale dell'uomo e degli animali, ma si ritrovano anche nelle piante e negli insetti.

Sono utilizzati come indicatori di contaminazione fecale nell'acqua e negli alimenti. Crescono a 10-45°C, in soluzione contenente fino al 6,5% di cloruro di sodio, a pH 9,6 e sopravvivono ad una temperatura di 60°C per 30 minuti.

Gli enterococchi sono batteri dotati di un basso potere patogeno ma possiedono geni che codificano la resistenza ad alcuni antibiotici, riescono perciò a sopravvivere negli ambienti in cui questi sono ampiamente utilizzati.

Negli ultimi 15 anni, infatti, si sono rivelati spesso causa d'infezioni ospedaliere.

Enterococci are Gram-positive bacteria that are very widespread in nature. They belong to the normal microbial flora of humans and animals, but can also be found in plants and insects.

They are used as indicators of faecal contamination of food and water.

They grow at 10-45°C, in a solution containing up to 6.5% sodium chloride, with pH 9.6, and can survive at 60°C for 30 minutes.

Enterococci are poorly-pathogenic bacteria, but they have genes that encode some antibiotic-resistance, so they can survive in environments in which antibiotics are widely used. Actually, over the last 15 years, they have often caused hospital-acquired infections.

Les entérocoques, bactéries à Gram positif, sont très répandus dans la nature. Ils font partie de la flore microbienne intestinale de l'homme et des animaux, et on les trouve aussi dans les plantes et les insectes. Ils sont utilisés comme indicateurs de contamination fécale de l'eau et des aliments. Ils prolifèrent entre 10 °C et 45 °C, dans une solution contenant jusqu'à 6,5% de chlorure de sodium à pH 9,6, et survivent pendant 30 minutes à une température de 60 °C. Les entérocoques sont des bactéries à faible pouvoir pathogène, mais dont les gènes codifient la résistance à certains antibiotiques, ce qui leur permet de survivre dans les milieux où ceux-ci sont amplement utilisés. Au cours des 15 dernières années, les entérocoques ont en effet souvent été responsables d'infections en milieu hospitalier.

Enterokokken sind Gram-positive Bakterien, die in der Natur stark verbreitet sind. Sie gehören zur mikrobiellen Darmflora der Menschen und Tiere, sind aber auch in Pflanzen und Insekten zu finden. Sie werden als Anzeiger fäkaler Kontaminationen im Wasser und in Nahrungsmitteln verwendet. Sie wachsen bei 10-45°C, in Lösungen mit bis zu 6,5% Natriumchlorid, mit pH 9,6 und überleben 30 Minuten lang einer Temperatur von 60°C. Enterokokken sind Bakterien mit einem niedrigen pathogenen Vermögen, sie besitzen jedoch Gene, welche die Widerstandsfähigkeit gegenüber einiger Antibiotika codieren und deshalb in Bereichen überleben, in denen diese im breiteren Umfang verwendet werden. In den letzten 15 Jahren haben sie sich in der Tat in Krankenhausbereichen oft als Infektionsursache erwiesen.



**PREMI E RICONOSCIMENTI**  
**AWARDS AND ACKNOWLEDGEMENTS**  
**PRIX ET RÉCOMPENSES**  
**PREISE UND AUSZEICHNUNGEN**

**Bios Self-Cleaning® - Bios Antibacterial®**

Hanno ricevuto i seguenti riconoscimenti internazionali  
 Have received the following International acknowledgements  
 Ont reçu les récompenses internationales suivantes:  
 Haben folgende internationale Auszeichnungen



**2015**  
 A+Award Popular Choice Winner  
 Categories | Building Products: Façades  
 BIOS SELF-CLEANING®



**2010**  
 Selezionata per l'ADI Design Index  
 BIOS ANTIBACTERIAL CERAMICS®



**2010**  
 AIT Innovation Award  
 "Architecture and  
 Building", Essen AIT e xia  
 IntelligenteArchitektur

BIOS ANTIBACTERIAL  
 CERAMICS®



**2010**  
 AIT Innovation Award  
 "Architecture and Flooring",  
 Hannover AIT e xia  
 IntelligenteArchitektur

BIOS ANTIBACTERIAL  
 CERAMICS®



**2011**  
 Produkt des Jahres  
 Fliesen&Platten Leserwahl

BIOS ANTIBACTERIAL  
 CERAMICS®



**2013**  
 Iconic Awards

BIOS ANTIBACTERIAL  
 CERAMICS®  
 BIOS SELF-CLEANING®



unicolore bios bianco avorio cm 30x60 - 11<sup>3</sup>/<sub>4</sub>"x23<sup>5</sup>/<sub>8</sub>"



## CERTIFICAZIONI CERTIFICATIONS CERTIFICATIONS ZERTIFIZIERUNGEN

Le prestazioni di **Bios Antibacterial**<sup>®</sup> sono conformi al regolamento europeo sui biocidi (BPR) e sono state testate e verificate dal Dipartimento di Scienze Biomediche, sezione di microbiologia, dell'Università di Modena e Reggio Emilia e dal Dipartimento di Farmacia e Biotecnologie dell'Università di Bologna

The performance of **Bios Antibacterial**<sup>®</sup> complies with the European Biocidal Products Regulation (BPR), and has been tested and verified by the Department of Biomedical Sciences, microbiology section, of the University of Modena and Reggio Emilia and the Department of Pharmacy and Biotechnologies of the University of Bologna.

Les performances de **Bios Antibacterial**<sup>®</sup> sont conformes au règlement européen sur les produits biocides (RPB). Elles ont été testées et vérifiées par le département de sciences biomédicales, section de microbiologie, de l'Université de Modène et de Reggio d'Émilie ainsi que par le département de pharmacie et de biotechnologies de l'Université de Bologne.

Die Leistungsmerkmale von **Bios Antibacterial**<sup>®</sup> entsprechen der Europäischen Biozid-Produkte-Verordnung (BPR) und wurden von der Abteilung für Biomedizinische Wissenschaften, Abteilung Mikrobiologie der Universität Modena und Reggio Emilia und der Abteilung für Pharmazie und Biotechnologie der Universität Bologna überprüft und zertifiziert.





**Università degli Studi di Modena e Reggio Emilia**  
 Dipartimento di Scienze Alimentari  
 Sezione di Microbiologia

**1** In data 28/03/2007 si è ricevuto da Casalgrande Padana spa il campione siglato:

Campione 4 – Bianchi A Tab 30x60  
 Tipo AA - Calibro 5  
 Produzione 26/03/2007

**2** Materiale fornito per la costruzione del  
**"CENTRO DI MEDICINA RIGENERATIVA"**  
 di Modena

**3** È stata saggiata l'attività antibatterica, espressa in percentuale di abbattimento della carica microbica, del campione nei confronti di:

<i>Staphylococcus aureus</i>	ATCC	6538
<i>Enterococcus faecalis</i>	ATCC	29212
<i>Escherichia coli</i>	ATCC	25922
<i>Pseudomonas aeruginosa</i>	ATCC	27859

**4** L'attività antibatterica del campione è risultata essere del 99,9% nei confronti dei germi testati.

**RESPONSABILE SCIENTIFICO**  
 Prof. Giuliano Mancardi

Via G. Galvani, 301, 41100 Modena Italy  
 Tel: +39 059 2151401, 2151795 Fax: 059 2151402 Email: segreteria@unimore.it

- 1 On March 28, 2007 Casalgrande Padana spa sent us the following sample:
2. This is one of the materials used for the building of the
3. We have analysed the antibacterial activity of the sample. It is expressed in terms of percent of abatement of the microbial load of the sample. We analysed the following:
4. The sample's antibacterial activity turned out to be 99.9% based on the germs we tested.

1. Le 28 mars 2007 la société Casalgrande Padana spa nous a fait parvenir l'échantillon suivant :
2. Il s'agit d'un des matériaux utilisés pour la réalisation du
3. Nous avons analysé l'activité antibactérienne de l'échantillon, exprimée en pourcentage de réduction de la charge microbienne de l'échantillon. Nous avons analysé les éléments suivants :
4. L'activité antibactérienne de l'échantillon, considérant les germes ayant fait l'objet de notre essai, est de 99,9%.

1. Am 28. März 2007 haben wir eine Stichprobe von Casalgrande Padana spa erhalten die folgendermaßen gekennzeichnet war:
2. Das Material dient dem Bau des
3. Es wurde die antibakterielle Wirksamkeit getestet, unter der prozentualen Angabe der antibakteriellen Reduktion des Musters, in Bezug auf:
4. Die antibakterielle Wirksamkeit des Musters in Bezug auf die getesteten Bakterien betrug 99,9%.



**Test method: ISO 27447:2009**  
 for determining the antibacterial activity of ceramic tiles

**Test method: Objectives**

Scope	For ceramic tiles
Product	For ceramic tiles
Sample	For ceramic tiles

Strain	ISO 27447:2009	EN	ISO 27447:2009
<i>Staphylococcus aureus</i>	ATCC 6538	6538	6538
<i>Enterococcus faecalis</i>	ATCC 29212	29212	29212
<i>Escherichia coli</i>	ATCC 25922	25922	25922
<i>Pseudomonas aeruginosa</i>	ATCC 27859	27859	27859

Scientific services  
 Dorena Carlo Sghia  
 Ceramica Italiana



**Test method: ISO 27447:2009**  
 for determining the antibacterial activity of ceramic tiles

**Test method: Objectives**

Scope	For ceramic tiles
Product	For ceramic tiles
Sample	For ceramic tiles

Strain	ISO 27447:2009	EN	ISO 27447:2009
<i>Staphylococcus aureus</i>	ATCC 6538	6538	6538
<i>Enterococcus faecalis</i>	ATCC 29212	29212	29212
<i>Escherichia coli</i>	ATCC 25922	25922	25922
<i>Pseudomonas aeruginosa</i>	ATCC 27859	27859	27859

Scientific services  
 Dorena Carlo Sghia  
 Ceramica Italiana

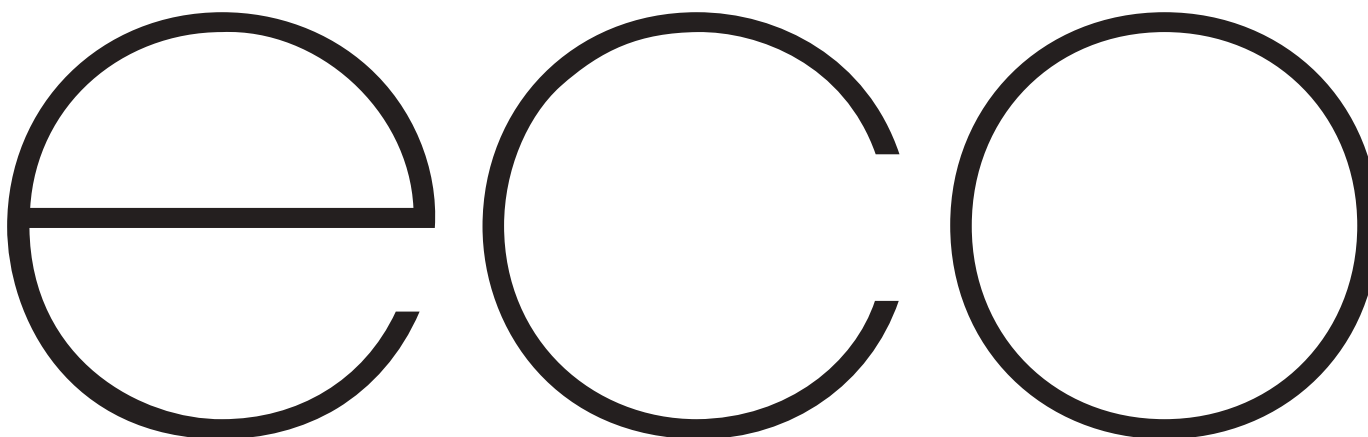
**ECOSOSTENIBILITÀ**

come filosofia di riferimento per realizzare prodotti ceramici evoluti, in grado di rispondere alla domanda più qualificata proveniente dal settore dell'architettura. Elementi in grès porcellanato prodotti da Casalgrande Padana attraverso un processo virtuoso e attento alla tutela dell'ambiente, capaci di coniugare libertà e flessibilità creativa con i più elevati contenuti tecnologici e prestazionali.

**ECO-SUSTAINABILITY**

as a reference philosophy for creating evolved ceramic products able to satisfy the most qualified demands from the sphere of architecture. Porcelain stoneware tiles produced by Casalgrande Padana through a virtuous process with safeguarding the environment as a prime concern, products that combine versatility and boundless scope for creativeness with the highest technological and performance specifications.

**ÉCO-DURABILITÉ**

comme philosophie de référence pour réaliser des produits céramiques évolués, en mesure de satisfaire la demande la plus qualifiée, provenant du secteur de l'architecture. Éléments en grès cérame produits par Casalgrande Padana à travers un procédé respectueux et soucieux de l'environnement, capables d'allier liberté et flexibilité créative aux plus hauts contenus technologiques et de performances.

**ÖKO-NACHHALTIGKEIT**

als Bezugsphilosophie, um ausgereifte Keramikprodukte zu realisieren, die in der Lage sind, der qualifiziertesten Nachfrage gerecht zu werden, die aus dem Sektor der Architektur kommt. Elemente aus Feinsteinzug, von Casalgrande Padana durch einen virtuoson und auf den Umweltschutz achtenden Prozess hergestellt, die in der Lage sind, kreative Freiheit und Flexibilität mit den höchsten technologischen und leistungsmäßigen Eigenschaften zu verbinden.





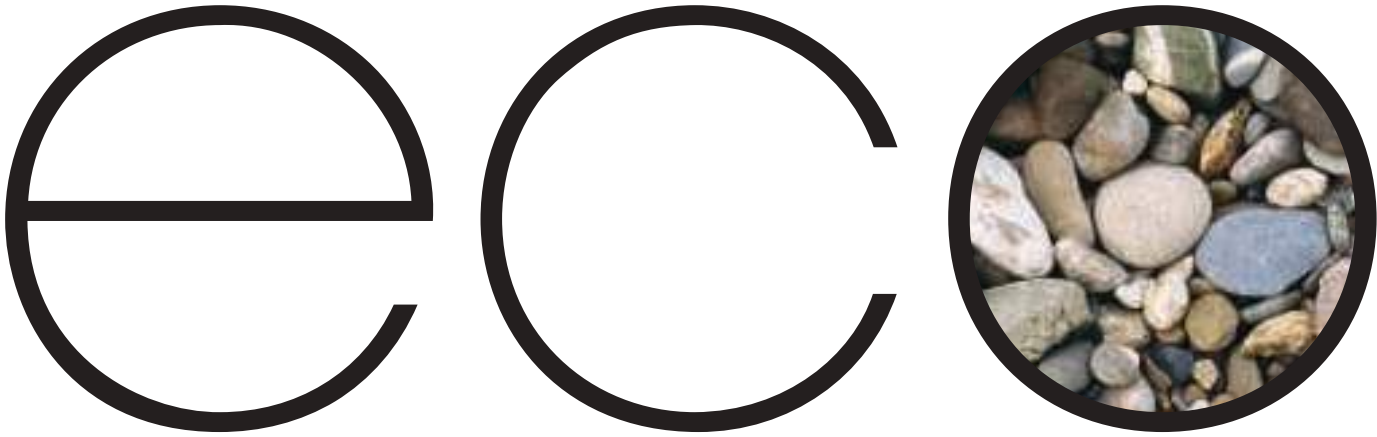

ecostone écopierre ökostein

pietra

# ecopietra

44	<b>pietre di paragone</b>
54	<b>amazzoneia</b>
60	<b>chalon</b>
66	<b>boulder</b>
72	<b>meteor</b>
78	<b>mineral chrom</b>
84	<b>pietra baugé</b>
90	<b>pietre di sardegna</b>
102	<b>stonewash</b>
106	<b>terre toscane</b>
112	<b>pietre etrusche</b>
118	<b>basaltina</b>
122	<b>kerblock</b>
126	<b>titano</b>
130	<b>ardesia</b>
134	<b>lavagna</b>
138	<b>patio</b>
142	<b>agorà</b>

## PIETRA

Roccia da costruzione o decorazione. La composizione mineralogica molto varia di questo gruppo di materiali viene classificata in due grandi categorie: Rocce tenere o poco compatte, tra le quali le sedimentarie [calcareniti, arenarie a cemento calcareo ecc.] e le piroclastiche come i tufi e i peperini; Rocce dure o compatte, tra le quali le pietre a spacco naturale [quarziti, micascisti, gneiss, lastroidi, ardesie ecc.] e alcune vulcaniti, come i basalti, le trachiti e i leucititi.

## STONE

Rock used for building or decorating purposes. The extremely varied mineralogical composition of this group of materials is divided into two large categories: Soft rocks or not very compact, including sedimentary rock [calcarenites, limy cement type sandstones, etc.] and pyroclastic materials like tuffs and peperino rocks; Hard rocks or compact ones, such as naturally split stones [quarzites, mica schists, gneiss, slab-structured rocks, slates, etc.] and certain volcanites, such as basalts, trachytes and leukocytes.

**pietre di paragone** pietra piacentina new

# pietre di paragone

PIETRE NATIVE



**pietra piacentina new** cm 90x180 - 35<sup>3</sup>/<sub>8</sub>"x70<sup>7</sup>/<sub>8</sub>", cm 90x90 - 35<sup>3</sup>/<sub>8</sub>"x35<sup>3</sup>/<sub>8</sub>"

## COLORI COLOURS COULEURS FARBEN

onsernone



gré grigio



gré bianco



pietra del cardoso



grigio tao



grigio aitos

Caratteristiche tecniche ed estetiche a pagina: Technical and aesthetics features on page:  
Caractéristiques techniques et esthétiques à la page : Technische und ästhetische Eigenschaften auf Seite: **438**



# pietre di paragone

PIETRE NATIVE

gré nero



pietra piacentina new



luni



vals

## FORMATI SIZES FORMATS FORMATE

Formati Sizes Formats Formate	cm 30x60 11 <sup>3</sup> / <sub>4</sub> "x23 <sup>5</sup> / <sub>8</sub> "	cm 60x60 23 <sup>5</sup> / <sub>8</sub> "x23 <sup>5</sup> / <sub>8</sub> "	cm 60x60 23 <sup>5</sup> / <sub>8</sub> "x23 <sup>5</sup> / <sub>8</sub> "	cm 60x120 23 <sup>5</sup> / <sub>8</sub> "x47 <sup>1</sup> / <sub>4</sub> "	cm 60x120 23 <sup>5</sup> / <sub>8</sub> "x47 <sup>1</sup> / <sub>4</sub> "	cm 45x90 17 <sup>3</sup> / <sub>4</sub> "x35 <sup>3</sup> / <sub>8</sub> "	cm 90x90 35 <sup>3</sup> / <sub>8</sub> "x35 <sup>3</sup> / <sub>8</sub> "	cm 90x180 35 <sup>3</sup> / <sub>8</sub> "x70 <sup>7</sup> / <sub>8</sub> "
Pletra Plasentina New	● ●	● ●		● ● *		●	●	●
Pietra del Cardoso	● ●	● ●		● ● *		●	●	●
Onsernone	● ●	● ●		● ● *				
Vals	● ●	● ●		● ● *				
Grigio Aitos	● ●	● ●		● ● *		●	●	●
Grigio Tao	● ●	● ●		● ● *		●	●	●
Gré Grigio	● ●	● ●	●	● ● *	●			
Gré Nero	● ●	● ●		● ● *				
Gré Bianco	● ●	● ●	●	● ● *	●			
Luni	● ●	● ●		● ● *		●	●	●
▽ ▲	mm 10 mm 9	mm 10	mm 20	mm 10	mm 20	mm 10	mm 10	mm 10



Vedi pagina: See page: Voir page: Siehe Seite: **448**

- Naturale Matt Naturelle Matt **R10 A**
- Grip **R12 A+B+C**
- \* Grip **R12 A+B+C**  
su richiesta on request  
sur demande Auf Anfrage können

Rettificate in un unico calibro Rectified version in a single caliber  
Rectifiés en un unique calibre Boden Sie in einem einzigen Kaliber

Caratteristiche tecniche e imballi a pagina: Technical features and packing on page:  
Caractéristiques techniques et emballages à la page: Technische Eigenschaften und Verpackungen auf Seite: **438**

## PEZZI SPECIALI TRIMS ACCESSOIRES FORMSTÜCKE

**Battiscopa Bullnose**  
Plinthe à bord arrondi  
Stehsockel  
cm 9x90 - 3<sup>1</sup>/<sub>2</sub>"x35<sup>3</sup>/<sub>8</sub>"  
cm 9x60 - 3<sup>1</sup>/<sub>2</sub>"x23<sup>5</sup>/<sub>8</sub>"



**Gradino Step tread**  
Nez de marche  
Stufenplatte  
cm 30x60 - 11<sup>3</sup>/<sub>4</sub>"x23<sup>5</sup>/<sub>8</sub>"  
cm 30x120 - 11<sup>3</sup>/<sub>4</sub>"x47<sup>1</sup>/<sub>4</sub>"

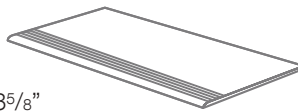

**Angolare (assemblato)**  
cm 120x33 - 35<sup>3</sup>/<sub>8</sub>"x47<sup>1</sup>/<sub>4</sub>"

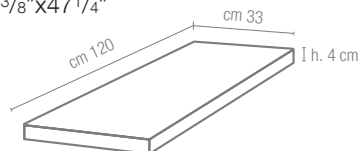

**Gradone (assemblato)**  
cm 120x33 - 47<sup>1</sup>/<sub>4</sub>"x13"

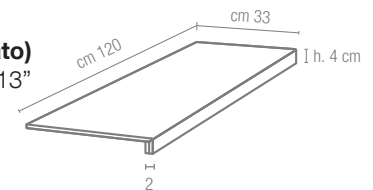

**Terminale** Pezzo unico pressato Pièce unique pressée  
Pressed single piece Gepresstes Einzelsück  
cm 15x30x3,5  
5<sup>7</sup>/<sub>8</sub>"x11<sup>3</sup>/<sub>4</sub>"x1<sup>3</sup>/<sub>8</sub>"

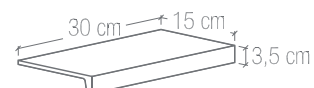

K Grandi Lastre K<sub>ontinua</sub>  
 K<sub>ontinua</sub> Big Slabs  
 Grandes Dalles K<sub>ontinua</sub>  
 K<sub>ontinua</sub> große Platten

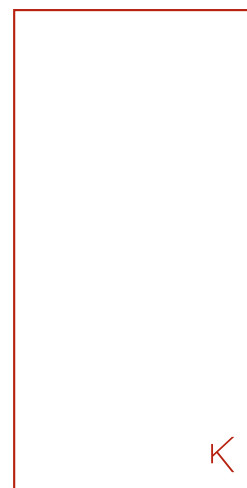
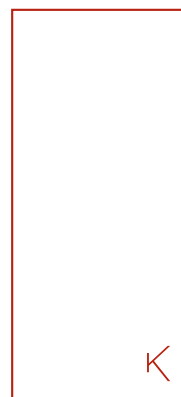
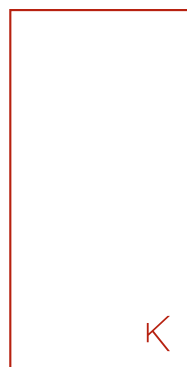
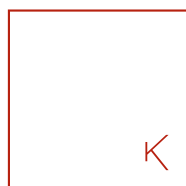

Formati Sizes Formats Formate	cm 120x120 47 <sup>1</sup> / <sub>4</sub> "x47 <sup>1</sup> / <sub>4</sub> "	cm 120x240 47 <sup>1</sup> / <sub>4</sub> "x94 <sup>1</sup> / <sub>2</sub> "	cm 120x260 47 <sup>1</sup> / <sub>4</sub> "x102 <sup>3</sup> / <sub>8</sub> "	cm 160x320 *** 63"x126"
<b>Pietra Placentina New</b>				
<b>Pietra del Cardoso</b>	●**	●**	●**	●**
<b>Onsernone</b>				
<b>Vals</b>				
<b>Grigio Aitos</b>	●**	●**	●**	
<b>Grigio Tao</b>	●**	●**	●**	●**
<b>Gré Grigio</b>	●**	●**	●**	●**
<b>Gré Nero</b>	●**▲			
<b>Gré Bianco</b>	●**	●**	●**	●**
<b>Luni</b>				
	mm 6,5 mm 10	mm 6,5	mm 6,5	mm 12

\*\*\* Non rettificato Not rectified Non rectifié Nicht rektifizierle

●\*\* Naturale Matt Naturelle Matt

▲ Solo nello spessore 10 mm Only in 10 mm thickness Seulement en épaisseur 10 mm Nur in 10 mm Stärke

## DECORI DECORS DÉCORS DEKORE

- Naturale Matt Naturelle Matt **R10 A**
- Grip **R12 A+B+C**
- \* Grip **R12 A+B+C**  
su richiesta on request  
sur demande Auf Anfrage können

■ Disponibile in tutti i colori della serie, superficie naturale e grip  
 Available in all the colours of the series, matt and grip surface  
 Disponible dans toutes les couleurs de la série, surface naturelle et grip  
 Verfügbar in allen Farben, matte und grip Oberfläche

### mosaico 6x6 ■



cm 30x30 - 11<sup>3</sup>/<sub>4</sub>"x11<sup>3</sup>/<sub>4</sub>"  
 tessera cm 6x6 - 2<sup>3</sup>/<sub>8</sub>"x2<sup>3</sup>/<sub>8</sub>"  
 su rete on net sur trame auf Netz

▼ mm 10 ▼ K<sub>ontinua</sub> mm 6,5

### mosaico 10x10 ■



cm 30x30 - 11<sup>3</sup>/<sub>4</sub>"x11<sup>3</sup>/<sub>4</sub>"  
 tessera cm 10x10 - 4"x4"  
 su rete on net sur trame auf Netz

## DECORI DECORS DÉCORS DEKORE

## diagonal



cm 120x240 47<sup>1</sup>/<sub>4</sub>"x 94<sup>1</sup>/<sub>2</sub>"

 Kontinua mm 6,5

Decoro abbinabile con  
 le collezioni Pietre di Paragone,  
 Pietre di Sardegna e Marmoker  
 Decor matching the Pietre di  
 Paragone, Pietre di Sardegna  
 and Marmoker collections  
 Décor pouvant être associé aux  
 collections Pietre di Paragone,  
 Pietre di Sardegna et Marmoker  
 Dekor kombinierbar mit den  
 Kollektionen Pietre di Paragone,  
 Pietre di Sardegna und Marmoker



diagonal cm 120x240 - 47<sup>1</sup>/<sub>4</sub>"x94<sup>1</sup>/<sub>2</sub>"

# pietre di paragone

PIETRE NATIVE

optical

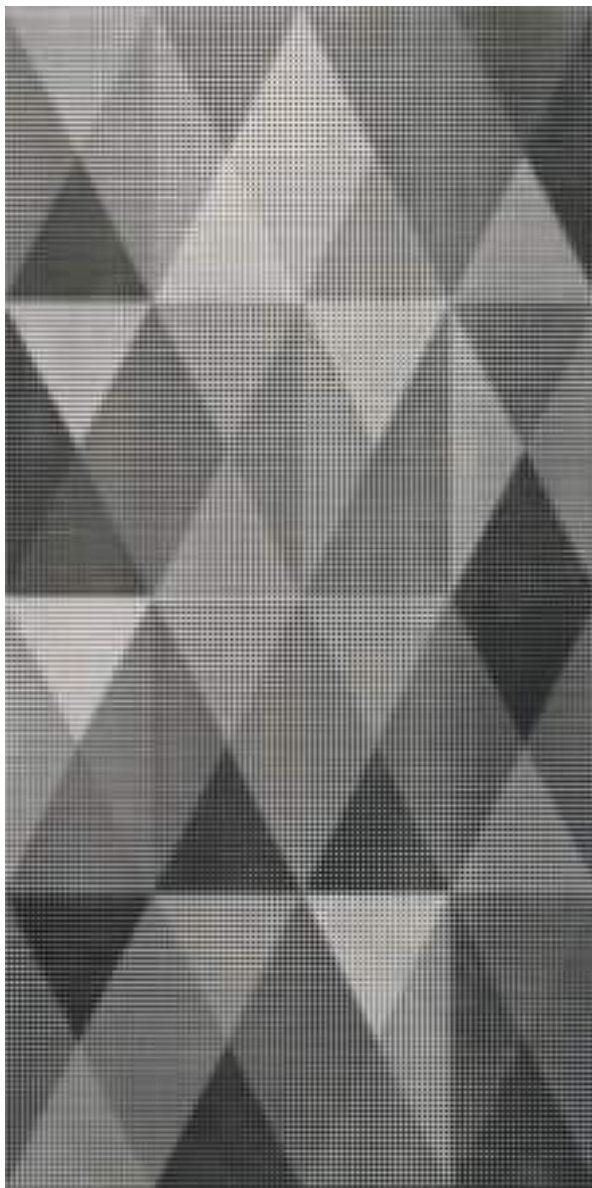

cm 120x240 47<sup>1</sup>/<sub>4</sub>"x 94<sup>1</sup>/<sub>2</sub>"

 Kontinua mm 6,5

Decoro abbinabile con  
le collezioni Pietre di Paragone,  
Pietre di Sardegna e Marmoker  
Decor matching the Pietre di  
Paragone, Pietre di Sardegna  
and Marmoker collections  
Décor pouvant être associé aux  
collections Pietre di Paragone,  
Pietre di Sardegna et Marmoker  
Dekor kombinierbar mit den  
Kollektionen Pietre di Paragone,  
Pietre di Sardegna und Marmoker



optical cm 120x240 - 47<sup>1</sup>/<sub>4</sub>"x94<sup>1</sup>/<sub>2</sub>"

## DECORI DECORS DÉCORS DEKORE

round square

cm 120x240 47<sup>1</sup>/<sub>4</sub>"x 94<sup>1</sup>/<sub>2</sub>"

 Kontinua mm 6,5

Decoro abbinabile con  
 le collezioni Pietre di Paragone,  
 Pietre di Sardegna e Marmoker  
 Decor matching the Pietre di  
 Paragone, Pietre di Sardegna  
 and Marmoker collections  
 Décor pouvant être associé aux  
 collections Pietre di Paragone,  
 Pietre di Sardegna et Marmoker  
 Dekor kombinierbar mit den  
 Kollektionen Pietre di Paragone,  
 Pietre di Sardegna und Marmoker



pietra del cardoso cm 120x240 - 47<sup>1</sup>/<sub>4</sub>"x94<sup>1</sup>/<sub>2</sub>"  
 round square cm 120x240 - 47<sup>1</sup>/<sub>4</sub>"x94<sup>1</sup>/<sub>2</sub>"

# pietre di paragone

PIETRE NATIVE

golden paint



cm 120x240 47<sup>1</sup>/<sub>4</sub>"x 94<sup>1</sup>/<sub>2</sub>"

 Kontinua mm 6,5

Decoro abbinabile con le collezioni Pietre di Paragone, Pietre di Sardegna e Marmoker  
 Decor matching the Pietre di Paragone, Pietre di Sardegna and Marmoker collections  
 Décor pouvant être associé aux collections Pietre di Paragone, Pietre di Sardegna et Marmoker  
 Dekor kombinierbar mit den Kollektionen Pietre di Paragone, Pietre di Sardegna und Marmoker



pietra del cardoso cm 120x240 - 47<sup>1</sup>/<sub>4</sub>"x94<sup>1</sup>/<sub>2</sub>"  
 golden paint cm 120x240 - 47<sup>1</sup>/<sub>4</sub>"x94<sup>1</sup>/<sub>2</sub>"

**amazzonia** dragon black



# amazzonia

PIETRE NATIVE



**dragon black** cm 45x90 - 17<sup>3</sup>/<sub>4</sub>"x35<sup>3</sup>/<sub>8</sub>"

## COLORI COLOURS COULEURS FARBEN

dragon black



dragon green



dragon grey



dragon brown



eldorado



dragon beige

Caratteristiche tecniche ed estetiche a pagina: Technical and aesthetics features on page:  
Caractéristiques techniques et esthétiques à la page : Technische und ästhetische Eigenschaften auf Seite: **438**

# amazzonia

PIETRE NATIVE

SUPERFICI SURFACES  
SURFACES OBERFLÄCHEN







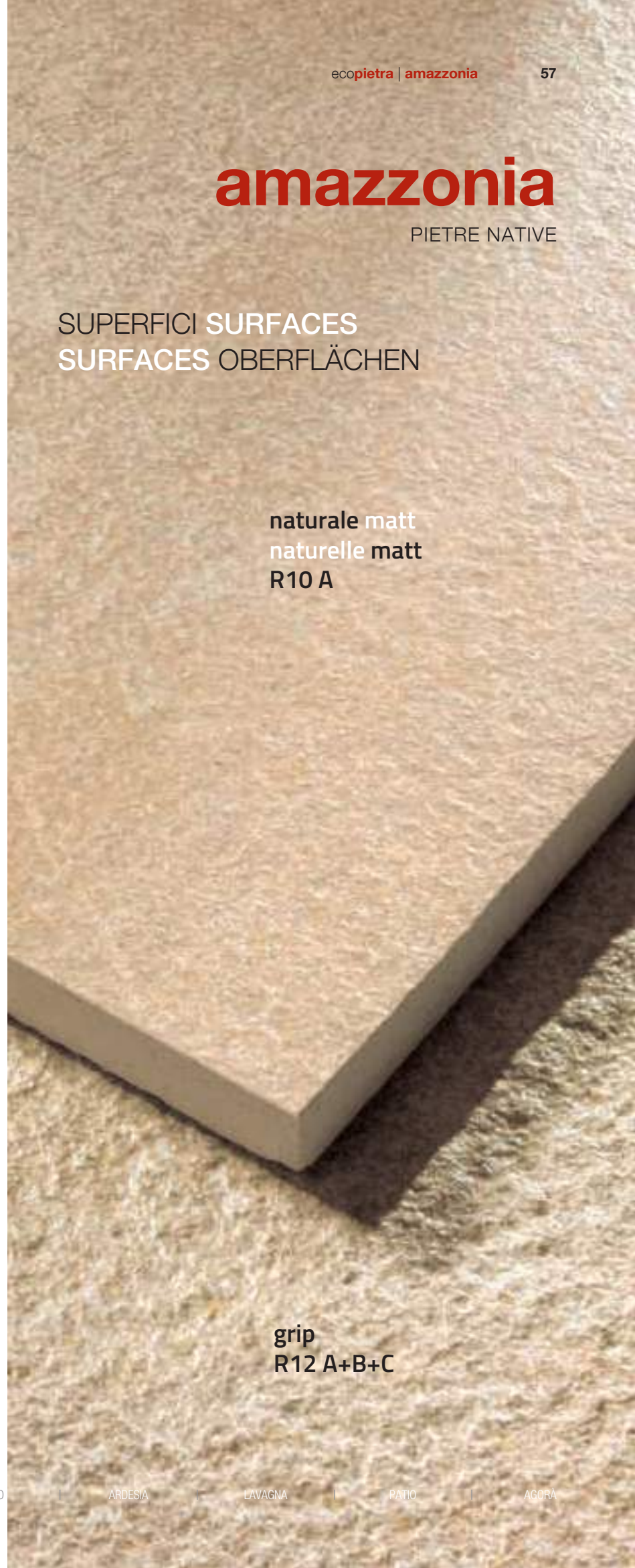





**naturale matt**  
**naturelle matt**  
**R10 A**

**grip**  
**R12 A+B+C**

**dragon white**





## FORMATI SIZES FORMATS FORMATE

Formati Sizes Formats Formate						
	<b>cm 30x30</b> 11 <sup>3</sup> / <sub>4</sub> "x11 <sup>3</sup> / <sub>4</sub> "	<b>cm 45x45</b> 17 <sup>3</sup> / <sub>4</sub> "x17 <sup>3</sup> / <sub>4</sub> "	<b>cm 30x60</b> 11 <sup>3</sup> / <sub>4</sub> "x23 <sup>5</sup> / <sub>8</sub> "	<b>cm 60x60</b> 23 <sup>5</sup> / <sub>8</sub> "x23 <sup>5</sup> / <sub>8</sub> "	<b>cm 45x90</b> 17 <sup>3</sup> / <sub>4</sub> "x35 <sup>3</sup> / <sub>8</sub> "	<b>cm 45x90</b> 17 <sup>3</sup> / <sub>4</sub> "x35 <sup>3</sup> / <sub>8</sub> "
Superfici Surfaces Surfaces Oberflächen						
	mm 9	mm 10	mm 10 mm 9 mm 9*	mm 10	mm 10	mm 20**



Accentuata  
Accentuated  
Importante  
Starke

Vedi pagina: See page: Voir page : Siehe Seite: **448**

 Naturale Matt Naturelle Matt **R10 A**  
 Grip **R12 A+B+C**

Rettificate in un unico calibro Rectified version in a single caliber Rectifiés en un unique calibre Boden Sie in einem einzigen Kaliber

\* Non rettificato Unrectified Non rectifié Nicht kalibriert

\*\* Solo nei colori: Only in the colours: Seulement dans les couleurs: Nur in die Farben: **Dragon Black, Dragon Grey, Dragon Beige, Dragon White, Dragon Brown**

Nel caso di combinazioni di formati di spessori diversi, specificarlo espressamente nell'ordine

Please specify in your order if you wish to purchase formats including more than one thickness

Prière de spécifier dans votre commande si vous souhaitez acheter des formats avec différentes épaisseurs

Bitte weisen Sie im Bestellungsformular ausdrücklich darauf hin, wenn Sie Formatkombinationen mit verschiedenen Stärken wünschen

Caratteristiche tecniche e imballi a pagina: Technical features and packing on page:

Caractéristiques techniques et emballages à la page: Technische Eigenschaften und Verpackungen auf Seite: **438**

## DECORI DECORS DÉCORS DEKORE

**mosaico 3x3\***



**cm 30x30** - 11<sup>3</sup>/<sub>4</sub>"x11<sup>3</sup>/<sub>4</sub>"  
tessera **cm 3x3** - 1<sup>1</sup>/<sub>8</sub>"x1<sup>1</sup>/<sub>8</sub>"  
su rete on net sur trame auf Netz

**mosaico 6x6\***



**cm 30x30** - 11<sup>3</sup>/<sub>4</sub>"x11<sup>3</sup>/<sub>4</sub>"  
tessera **cm 6x6** - 2<sup>3</sup>/<sub>8</sub>"x2<sup>3</sup>/<sub>8</sub>"  
su rete on net sur trame auf Netz

**composizione A\***

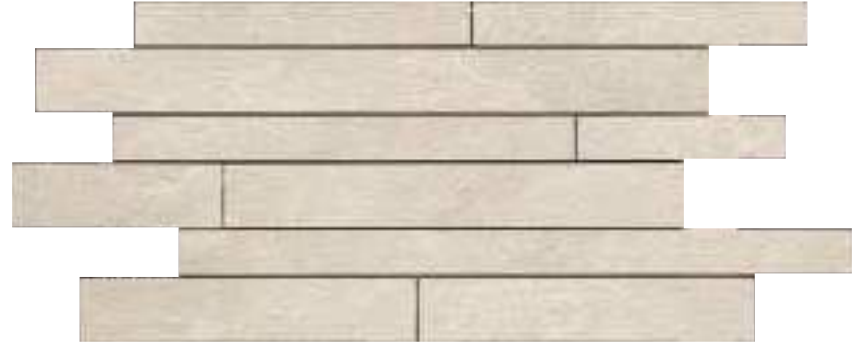

**cm 30x60** - 11<sup>3</sup>/<sub>4</sub>"x23<sup>5</sup>/<sub>8</sub>"  
su rete on net sur trame auf Netz

\* Disponibile in tutti i colori della serie su superficie naturale. A richiesta su superficie grip. Available in all the matt colours. On request also on grip surface.

Disponibile dans toutes les couleurs pour la surface naturelle. Sur demande la finition grip. Verfügbar in allen Farben der Serie, matte Oberfläche. Auf Anfrage grip Oberfläche.

## PEZZI SPECIALI TRIMS ACCESSOIRES FORMSTÜCKE

# amazzonia

PIETRE NATIVE

▲ 2pcs  45°

**Battiscopa Bullnose**  
Plinthe à bord arrondi  
**Stehsockel**  
cm 9x45 - 3 1/2"x17 3/4"  
cm 9x60 - 3 1/2"x23 5/8"



**Bordo**  
**Terminale Gradino B.C.**  
cm 9x30 - 3 1/2"x11 3/4"  
cm 9x45 - 3 1/2"x17 3/4"



**Bordo**  
**Terminale Gradino B.C.**  
cm 9x60 - 3 1/2"x23 5/8"

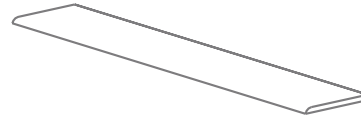

**Angolo**  
**terminale gradino B.C.**  
Art. 9900  
cm 9x9 - 3 1/2"x3 1/2"



**Terminale** Pezzo unico pressato  
Pièce unique pressée  
Pressed single piece  
Gepresstes Einzelsück  
cm 15x30x3,5 - 5 7/8"x11 3/4"x1 3/8"

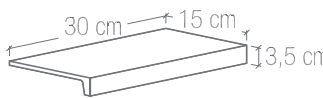

**Gradino Step tread**  
**Nez de marche Stufenplatte**  
cm 45x45 - 17 3/4"x17 3/4"  
cm 30x60 - 11 3/4"x23 5/8"

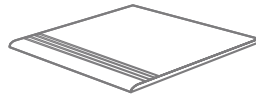

**Gradone (assemblato)**  
cm 60x33 - 23 5/8"x13"

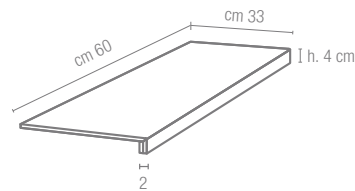

**Angolare (assemblato)**  
cm 60x33 - 23 5/8"x13"

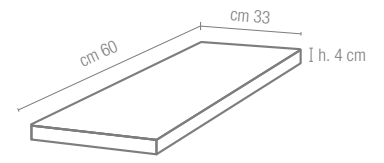

**Griglia Art. 9883**  
cm 30x40x2 - 11 3/4"x15 3/4"x3/4"

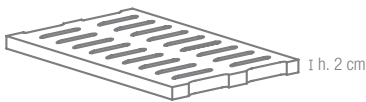

**Griglia angolare Art. 9884** ▲  
cm 30x40x2 - 11 3/4"x15 3/4"x3/4"

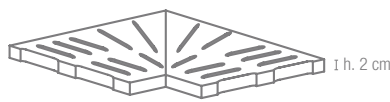

**Griglia Art. 9885**  
cm 13x40x2 - 5 1/8"x15 3/4"x3/4"

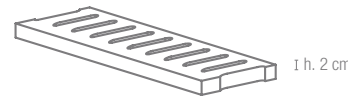

**Griglia angolare Art. 9886** ▲  
cm 13x40x2 - 5 1/8"x15 3/4"x3/4"

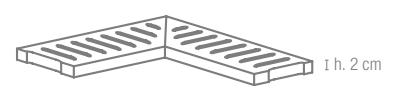

**Art. 9560**  
cm 33x90 - 13" x35 3/8"

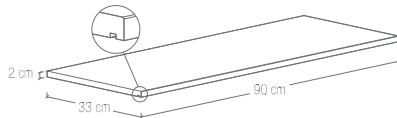

**Art. 9567** ▲  
cm 45x45 - 17 3/4"x17 3/4"

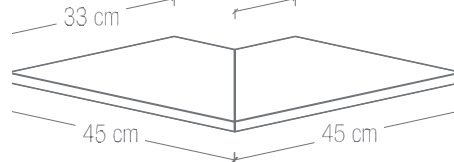

**Art. 9568** ▲  
cm 45x45 - 7 3/4"x17 3/4"

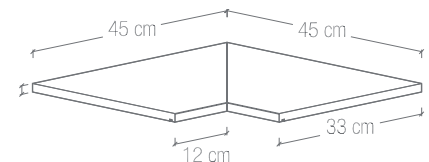

**Art. 9833**  
cm 2x2 - 3/4"x3/4"



**Art. 9834**  
cm 5x5x2 - 1 7/8"x1 7/8"x3/4"



**Art. 9830**  
cm 2x30 - 3/4"x11 3/4"

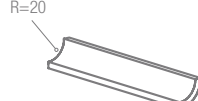

**Art. 9835 grip**  
cm 3x30 - 1 1/8"x11 3/4"

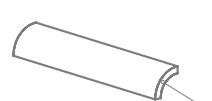

**Art. 9837 grip**  
cm 3x3 - 1 1/8"x1 1/8"



**Art. 9838 grip**  
cm 5x3x2 - 1 7/8"x1 1/8"x3/4"



**Art. 9660 Pool Wave**  
cm 60x25 - 23 5/8"x9 7/8"

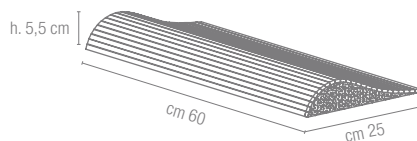

**Art. 9667 Pool Wave** ▲  
cm 25x29 - 9 7/8"x11 1/2"

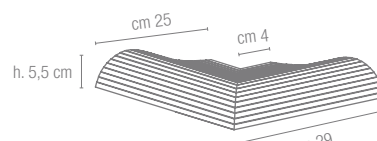

**Art. 9668 Pool Wave** ▲  
cm 25x29 - 9 7/8"x11 1/2"

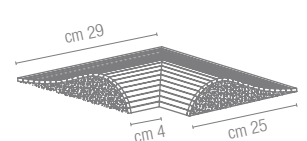

**chalon** cream

# chalon

PIETRE NATIVE



**chalon cream** cm 60x60 - 23<sup>5</sup>/<sub>8</sub>"x23<sup>5</sup>/<sub>8</sub>"

## COLORI COLOURS COULEURS FARBEN

chalon kaki



chalon beige



chalon grey



chalon cream

Caratteristiche tecniche ed estetiche a pagina: Technical and aesthetics features on page:  
Caractéristiques techniques et esthétiques à la page : Technische und ästhetische Eigenschaften auf Seite: **438**



SUPERFICI SURFACES  
SURFACES OBERFLÄCHEN

**chalon**







PIETRE NATIVE

**lappata**

**naturale matt  
naturelle matt  
R10**

**grip  
R12**

## FORMATI SIZES FORMATS FORMATE

Formati Sizes Formats Formate					
	<b>cm 45x45</b> 17 <sup>3</sup> / <sub>4</sub> "x17 <sup>3</sup> / <sub>4</sub> "	<b>cm 30x60</b> 11 <sup>3</sup> / <sub>4</sub> "x23 <sup>5</sup> / <sub>8</sub> "	<b>cm 60x60</b> 23 <sup>5</sup> / <sub>8</sub> "x23 <sup>5</sup> / <sub>8</sub> "	<b>cm 60x120</b> 23 <sup>5</sup> / <sub>8</sub> "x47 <sup>1</sup> / <sub>4</sub> "	<b>cm 60x120 *</b> 23 <sup>5</sup> / <sub>8</sub> "x47 <sup>1</sup> / <sub>4</sub> "
Superfici Surfaces Surfaces Oberflächen	●	● ● ●	● ● ●	● ● ●	●
	mm 9	mm 10 mm 9	mm 10	mm 10	mm 20



Accentuata  
Accentuated  
Importante  
Starke

Vedi pagina: See page: Voir page : Siehe Seite: **448**

● Naturale Matt Naturelle Matt **R10**  
● Lappata  
● Grip **R12**

Rettificate in un unico calibro Rectified version in a single caliber Rectifiés en un unique calibre Boden Sie in einem einzigen Kaliber

\* Disponibile nei colori: Available in the colours: Disponible dans les couleurs: Verfügbar in den folgenden Farben: **Beige, Cream, Grey**

Caratteristiche tecniche e imballi a pagina: Technical features and packing on page:

Caractéristiques techniques et emballages à la page: Technische Eigenschaften und Verpackungen auf Seite: **438**

## PEZZI SPECIALI TRIMS ACCESSOIRES FORMSTÜCKE

▲ 2pcs  45°

**Battiscopa Bullnose**  
**Plinthe à bord arrondi**  
**Stehsockel**  
**cm 9x60 - 3<sup>1</sup>/<sub>2</sub>"x23<sup>5</sup>/<sub>8</sub>"**



**Gradino Step tread**  
**Nez de marche**  
**Stufenplatte**  
**cm 30x60 - 11<sup>3</sup>/<sub>4</sub>"x23<sup>5</sup>/<sub>8</sub>"**  
**cm 30x120 - 11<sup>3</sup>/<sub>4</sub>"x47<sup>1</sup>/<sub>4</sub>"**

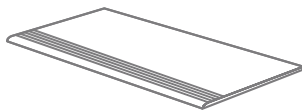

**Gradone (assemblato)**  
**cm 120x33 - 47<sup>1</sup>/<sub>4</sub>"x13"**

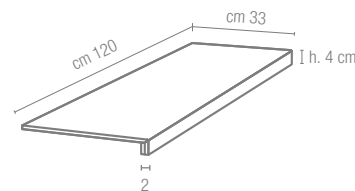

**Angolare (assemblato)**  
**cm 120x33 - 47<sup>1</sup>/<sub>4</sub>"x13"**

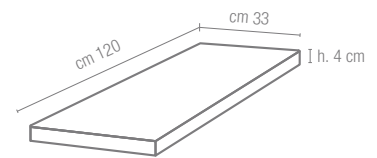

**Art. 9550**  
**cm 33x60 - 13"x23<sup>5</sup>/<sub>8</sub>"**

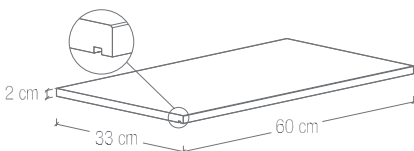

**Art. 9557 ▲**  
**cm 60x60 - 23<sup>5</sup>/<sub>8</sub>"x23<sup>5</sup>/<sub>8</sub>"**

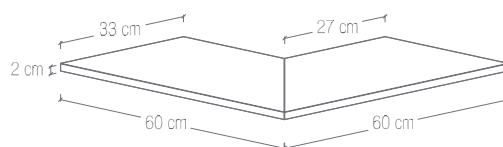

**Art. 9558 ▲**  
**cm 60x60 - 23<sup>5</sup>/<sub>8</sub>"x23<sup>5</sup>/<sub>8</sub>"**

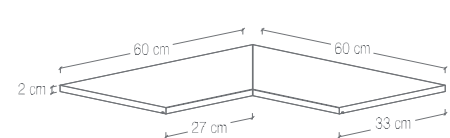

## DECORI DECORS DÉCORS DEKORE

**chalon**

PIETRE NATIVE

mosaico 6x6\*



**cm 30x30** - 11<sup>3</sup>/<sub>4</sub>"x11<sup>3</sup>/<sub>4</sub>"  
 tessera **cm 6x6** - 2<sup>3</sup>/<sub>8</sub>"x2<sup>3</sup>/<sub>8</sub>"  
 su rete on net sur trame auf Netz

mosaico 10x10\*



**cm 30x30** - 11<sup>3</sup>/<sub>4</sub>"x11<sup>3</sup>/<sub>4</sub>"  
 tessera **cm 10x10** - 4"x4"  
 su rete on net sur trame auf Netz

\* Disponibile in tutti i colori della serie su superficie naturale. A richiesta su superficie grip e lappata Available in all the matt colours. On request also on grip and lappata surface  
 Disponible dans toutes les couleurs pour la surface naturelle. Sur demande la finition grip et lappata Verfügbar in allen Farben der Serie, matte Oberfläche. Auf Anfrage grip und lappata Oberfläche



**chalon kaki** cm 60x60 - 23<sup>5</sup>/<sub>8</sub>"x23<sup>5</sup>/<sub>8</sub>"

**boulder** fossil

# boulder

PIETRE NATIVE



**fossil** cm 30x60 - 11<sup>3</sup>/<sub>4</sub>"x23<sup>5</sup>/<sub>8</sub>"

## COLORI COLOURS COULEURS FARBEN

ink



rust



fossil

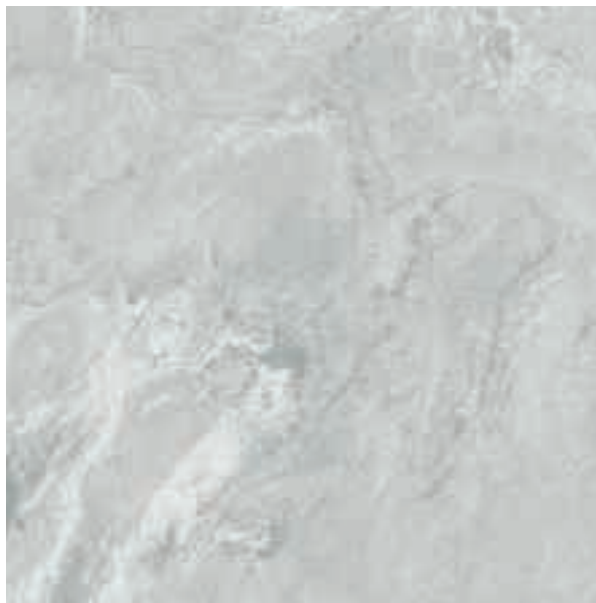

cloud

Caratteristiche tecniche ed estetiche a pagina: Technical and aesthetics features on page:  
Caractéristiques techniques et esthétiques à la page : Technische und ästhetische Eigenschaften auf Seite: **438**







# boulder

PIETRE NATIVE



rust cm 30x60 - 11<sup>3</sup>/<sub>4</sub>"x23<sup>5</sup>/<sub>8</sub>"

## FORMATI SIZES FORMATS FORMATE

Formati Sizes Formats Formate		
	<b>cm 30x60</b> 11 <sup>3</sup> / <sub>4</sub> "x23 <sup>5</sup> / <sub>8</sub> "	<b>cm 45x90</b> 17 <sup>3</sup> / <sub>4</sub> "x35 <sup>3</sup> / <sub>8</sub> "
Superfici Surfaces Surfaces Oberflächen		
	mm 9 mm 9*	mm 10
 Accentuata Accentuated Importante Starke	● Naturale Matt Naturelle Matt <b>R10 A+B</b> ● Grip <b>R11</b>	

Vedi pagina: See page: Voir page : Siehe Seite: **448**

Rettificate in un unico calibro Single caliber, rectified version Rectifiés en un unique calibre Einem einzigen Werkmass maßgeschliffen geliefert

\* Non rettificato Unrectified Non rectifié Nicht kalibriert

Caratteristiche tecniche e imballi a pagina: Technical features and packing on page:

Caractéristiques techniques et emballages à la page: Technische Eigenschaften und Verpackungen auf Seite: **438**

## PEZZI SPECIALI TRIMS ACCESSOIRES FORMSTÜCKE

▲ 2pcs  45°

**Battiscopa Bullnose**  
**Plinthe à bord arrondi**  
**Stehsokkel**  
cm 7x60 - 2<sup>3</sup>/<sub>4</sub>"x23<sup>5</sup>/<sub>8</sub>"  
cm 7x90 - 2<sup>3</sup>/<sub>4</sub>"x35<sup>3</sup>/<sub>8</sub>"



**Gradino Step tread**  
**Nez de marche**  
**Stufenplatte**  
cm 30x60 - 11<sup>3</sup>/<sub>4</sub>"x23<sup>5</sup>/<sub>8</sub>"

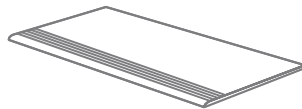

**Art. 9660 Pool Wave**  
cm 60x25 - 23<sup>5</sup>/<sub>8</sub>"x9<sup>7</sup>/<sub>8</sub>"

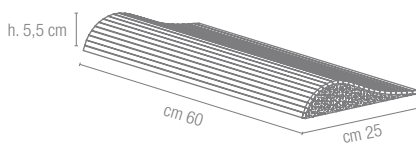

**Art. 9667 Pool Wave ▲**  
cm 25x29 - 9<sup>7</sup>/<sub>8</sub>"x11<sup>1</sup>/<sub>2</sub>"

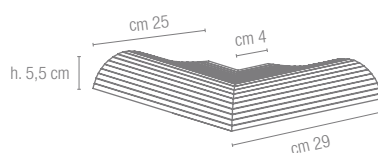

**Art. 9668 Pool Wave ▲**  
cm 25x29 - 9<sup>7</sup>/<sub>8</sub>"x11<sup>1</sup>/<sub>2</sub>"

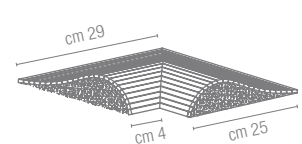



## DECORI DECORS DÉCORS DEKORE

**boulder**

PIETRE NATIVE

mosaico 6x6\*



**cm 30x30** - 11<sup>3</sup>/<sub>4</sub>"x11<sup>3</sup>/<sub>4</sub>"  
 tessera **cm 6x6** - 2<sup>3</sup>/<sub>8</sub>"x2<sup>3</sup>/<sub>8</sub>"  
*su rete on net sur trame auf Netz*

boulder composizione A\*



**cm 30x60** - 11<sup>3</sup>/<sub>4</sub>"x23<sup>5</sup>/<sub>8</sub>"  
*su rete on net sur trame auf Netz*

\* Disponibile in tutti i colori, superficie naturale. Available in all the colours, matt surface.  
 Disponible dans toutes les couleurs, surface naturelle. Verfügbar in allen Farben, matte Oberfläche.

ink cm 30x60 - 11<sup>3</sup>/<sub>4</sub>"x23<sup>5</sup>/<sub>8</sub>"

meteor grigio

# meteor

PIETRE NATIVE



**meteor grigio** cm 30x30 - 11<sup>3</sup>/<sub>4</sub>"x11<sup>3</sup>/<sub>4</sub>"

## COLORI COLOURS COULEURS FARBEN

meteor grafite



meteor nero



meteor grigio



meteor brown



meteor noce



meteor beige

Caratteristiche tecniche ed estetiche a pagina: Technical and aesthetics features on page:  
Caractéristiques techniques et esthétiques à la page : Technische und ästhetische Eigenschaften auf Seite: **438**

# meteor

PIETRE NATIVE

meteor perla







meteor bianco



meteor almond

## FORMATI SIZES FORMATS FORMATE

Formati Sizes Formats Formate	 <b>cm 30x30</b> 11 <sup>3</sup> / <sub>4</sub> "x11 <sup>3</sup> / <sub>4</sub> "	 <b>cm 45x45</b> 17 <sup>3</sup> / <sub>4</sub> "x17 <sup>3</sup> / <sub>4</sub> "	 <b>cm 30x60</b> 11 <sup>3</sup> / <sub>4</sub> "x23 <sup>5</sup> / <sub>8</sub> "	 <b>cm 60x60</b> 23 <sup>5</sup> / <sub>8</sub> "x23 <sup>5</sup> / <sub>8</sub> "
Superfici Surfaces Surfaces Oberflächen	●	●	● ●**	● ●
	mm 9 mm 8*	mm 9*	mm 10 mm 9 mm 9*	mm 10



Media  
Medium  
Modérée  
Mittlere

Vedi pagina: See page: Voir page : Siehe Seite: **448**

● Naturale Matt Naturelle Matt **R10**

● Lappata

●\*\* Lappata

Solo nello spessore 10 mm

Only in 10 mm thickness

Seulement en épaisseur 10 mm

Nur in 10 mm Stärke

Rettificate in un unico calibro Rectified version in a single caliber Rectifiés en un unique calibre Boden Sie in einem einzigen Kaliber

Nel caso di combinazioni di formati di spessori diversi, specificarlo espressamente nell'ordine Please specify in your order if you wish to purchase formats including more than one thickness  
Prière de spécifier dans votre commande si vous souhaitez acheter des formats avec différentes épaisseurs Bitte weisen Sie im Bestellungsformular ausdrücklich darauf hin, wenn Sie  
Formatkombinationen mit verschiedenen Stärken wünschen

\* Solo naturale, versione non rettificata e solo nei colori: Only matt, not rectified version and only in the colours:

Seulement naturel, version non rectifiée et seulement dans les couleurs : Nur matt, in der nicht rektifizierte Version und in die Farben:

**Nero, Grigio, Noce, Beige, Almond, Bianco**

Caratteristiche tecniche e imballi a pagina: Technical features and packing on page:

Caractéristiques techniques et emballages à la page: Technische Eigenschaften und Verpackungen auf Seite: **438**

## PEZZI SPECIALI TRIMS ACCESSOIRES FORMSTÜCKE

**Battiscopa Bullnose**  
**Plinthe à bord arrondi**  
**Stehsockel**

cm 9x30 - 3<sup>1</sup>/<sub>2</sub>"x11<sup>3</sup>/<sub>4</sub>"

cm 9x45 - 3<sup>1</sup>/<sub>2</sub>"x17<sup>3</sup>/<sub>4</sub>"

cm 9x60 - 3<sup>1</sup>/<sub>2</sub>"x23<sup>5</sup>/<sub>8</sub>"



**Gradino Step tread**  
**Nez de marche Stufenplatte**

cm 30x30 - 11<sup>3</sup>/<sub>4</sub>"x11<sup>3</sup>/<sub>4</sub>"

cm 30x60 - 11<sup>3</sup>/<sub>4</sub>"x23<sup>5</sup>/<sub>8</sub>"

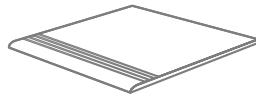

**Gradone (assemblato)**

cm 30x33 - 11<sup>3</sup>/<sub>4</sub>"x13"

cm 60x33 - 23<sup>5</sup>/<sub>8</sub>"x13"

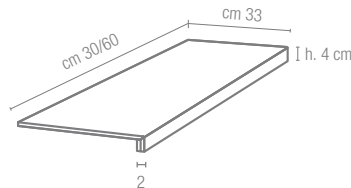

**Angolare (assemblato)**

cm 30x33 - 11<sup>3</sup>/<sub>4</sub>"x13"

cm 60x33 - 23<sup>5</sup>/<sub>8</sub>"x13"

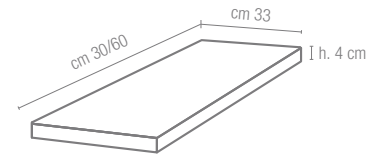

## DECORI DECORS DÉCORS DEKORE

**meteor**

PIETRE NATIVE

mosaico 3x3\*

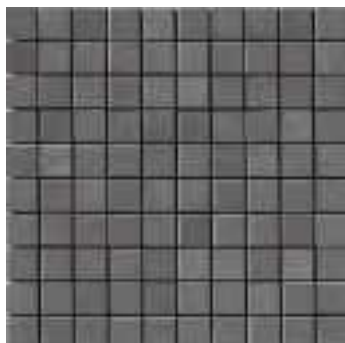

**cm 30x30** - 11<sup>3</sup>/<sub>4</sub>"x11<sup>3</sup>/<sub>4</sub>"  
 tessera **cm 3x3** - 1<sup>1</sup>/<sub>8</sub>"x1<sup>1</sup>/<sub>8</sub>"  
*su rete on net sur trame auf Netz*

mosaico 6x6\*



**cm 30x30** - 11<sup>3</sup>/<sub>4</sub>"x11<sup>3</sup>/<sub>4</sub>"  
 tessera **cm 6x6** - 2<sup>3</sup>/<sub>8</sub>"x2<sup>3</sup>/<sub>8</sub>"  
*su rete on net sur trame auf Netz*

\* Disponibile in tutti i colori della serie, superficie naturale Available in all the colours of the series, matt surface  
 Disponible dans toutes les couleurs de la série, surface naturelle Verfügbar in allen Farben, matte Oberfläche

Complementi in acciaio e alluminio a pagina: Technical features on page: Caractéristiques techniques à la page: Technische eigenschaften auf Seite: **449**



**meteor bianco cm 30x60** - 11<sup>3</sup>/<sub>4</sub>"x23<sup>5</sup>/<sub>8</sub>"

**mineral chrom** grey



# mineral chrom

PIETRE NATIVE



**mineral grey** cm 30x60 - 11<sup>3</sup>/<sub>4</sub>"x23<sup>5</sup>/<sub>8</sub>", cm 30x30 - 11<sup>3</sup>/<sub>4</sub>"x11<sup>3</sup>/<sub>4</sub>"

## COLORI COLOURS COULEURS FARBEN

mineral black



mineral grey



mineral white



mineral brown



mineral gold



mineral beige











Caratteristiche tecniche ed estetiche a pagina: Technical and aesthetics features on page:  
Caractéristiques techniques et esthétiques à la page : Technische und ästhetische Eigenschaften auf Seite: **438**

# mineral chrom

PIETRE NATIVE

**mineral brown** cm 30x60 - 11<sup>3</sup>/<sub>4</sub>"x23<sup>5</sup>/<sub>8</sub>"  
**mosaico mineral brown 3x3** cm 30x30 - 11<sup>3</sup>/<sub>4</sub>"x11<sup>3</sup>/<sub>4</sub>"  
**mosaico mineral brown 6x6** cm 30x30 - 11<sup>3</sup>/<sub>4</sub>"x11<sup>3</sup>/<sub>4</sub>"

## FORMATI SIZES FORMATS FORMATE

Formati Sizes Formats Formate	 <b>cm 30x30</b> 11 <sup>3</sup> / <sub>4</sub> "x11 <sup>3</sup> / <sub>4</sub> "	 <b>cm 30x60</b> 11 <sup>3</sup> / <sub>4</sub> "x23 <sup>5</sup> / <sub>8</sub> "
Superfici Surfaces Surfaces Oberflächen	 	 
 	mm 9	mm 9
 Accentuata Accentuated Importante Starke		 Soft <b>R10 A+B</b>  Naturale Matt Naturelle Matt <b>R11 A+B</b>

Vedi pagina: See page: Voir page : Siehe Seite: **448**

Rettificata in un unico calibro Rectified version in a single caliber Rectifiés en un unique calibre Boden Sie in einem einzigen Kaliber

Nel caso di combinazioni di formati di spessori diversi, specificarlo espressamente nell'ordine Please specify in your order if you wish to purchase formats including more than one thickness Prière de spécifier dans votre commande si vous souhaitez acheter des formats avec différentes épaisseurs Bitte weisen Sie im Bestellungsformular ausdrücklich darauf hin, wenn Sie Formatkombinationen mit verschiedenen Stärken wünschen

Caratteristiche tecniche e imballi a pagina: Technical features and packing on page:

Caractéristiques techniques et emballages à la page: Technische Eigenschaften und Verpackungen auf Seite: **438**

## DECORI DECORS DÉCORS DEKORE

**mosaico 3x3\***



**cm 30x30** - 11<sup>3</sup>/<sub>4</sub>"x11<sup>3</sup>/<sub>4</sub>"  
tessera **cm 3x3** - 1<sup>1</sup>/<sub>8</sub>"x1<sup>1</sup>/<sub>8</sub>"  
su rete on net sur trame auf Netz

**mosaico 6x6\***



**cm 30x30** - 11<sup>3</sup>/<sub>4</sub>"x11<sup>3</sup>/<sub>4</sub>"  
tessera **cm 6x6** - 2<sup>3</sup>/<sub>8</sub>"x2<sup>3</sup>/<sub>8</sub>"  
su rete on net sur trame auf Netz

**composizione A\*\***



**cm 30x60** - 11<sup>3</sup>/<sub>4</sub>"x23<sup>5</sup>/<sub>8</sub>"  
su rete on net sur trame auf Netz

\* Disponibile in tutti i colori della serie, superficie naturale e "soft" Available in all the colours of the series, matt and "soft" surface  
Disponibile dans toutes les couleurs de la série, surface naturelle et "soft" Verfügbar in allen Farben, matte und "soft" Oberfläche

\*\* Disponibile in tutti i colori della serie su superficie "soft" Available in all the "soft" colours  
Disponibile dans toutes les couleurs pour la surface "soft" Verfügbar in allen Farben der Serie, "soft" Oberfläche

Complementi in acciaio e alluminio a pagina: Technical features on page: Caractéristiques techniques à la page: Technische Eigenschaften auf Seite: **449**

PEZZI SPECIALI TRIMS  
ACCESSOIRES FORMSTÜCKE

# mineral chrom

PIETRE NATIVE

▲ 2pcs  45°

**Battiscopa Bullnose**  
**Plinthe à bord arrondi**  
**Stehsockel**  
cm 9x30 - 3 1/2"x11 3/4"

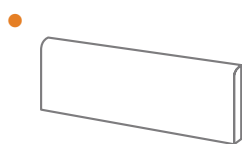

**Terminale gradino B.C.**  
cm 9x30 - 3 1/2"x11 3/4"



**Art. 9900**  
**Angolo terminale**  
**gradino B.C.**  
cm 9x9 - 3 1/2"x3 1/2"

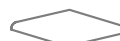

**Gradino Step tread**  
**Nez de marche Stufenplatte**  
cm 30x30 - 11 3/4"x11 3/4"  
cm 30x60 - 11 3/4"x23 5/8"

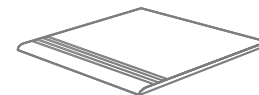

**Gradone (assemblato)**  
cm 30x33 - 11 3/4"x13"

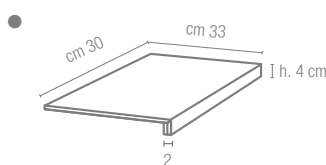

**Angolare (assemblato)**  
cm 30x33 - 11 3/4"x13"

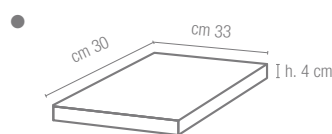

**Gradino B.C. Step tread B.C.**  
**Nez de marche B.C. Stufenplatte B.C.**  
cm 30x30 - 11 3/4"x11 3/4"  
cm 30x60 - 11 3/4"x23 5/8"

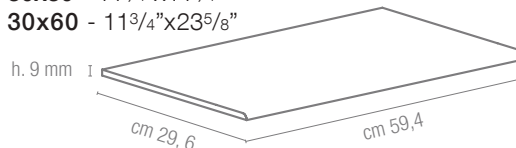

**Art. 9830**  
cm 2x30 - 3/4"x11 3/4"

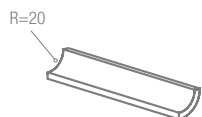

**Art. 9833**  
cm 2x2 - 3/4"x3/4"



**Art. 9834**  
cm 5x5x2 - 1 7/8"x 1 7/8"x3/4"



**Art. 9835**  
cm 3x30 - 1 1/8"x 11 3/4"

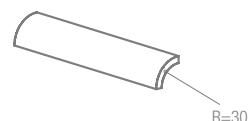

**Art. 9837**  
cm 3x3 - 1 1/8"x1 1/8"



**Art. 9838**  
cm 5x3x2 - 1 7/8"x1 1/8"x3/4"



**Terminale Pezzo unico pressato**  
Pièce unique pressée  
Pressed single piece  
Gepresstes Einzelsück  
cm 15x30x3,5  
5 7/8"x11 3/4"x1 3/8"

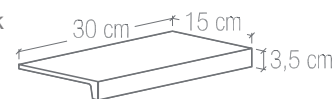

**Art. 9660 Pool Wave**  
cm 60x25 - 23 5/8"x9 7/8"

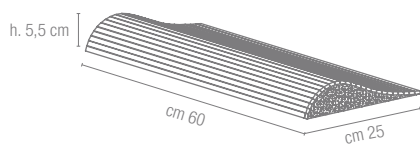

**Art. 9667 Pool Wave ▲**  
cm 25x29 - 9 7/8"x11 1/2"

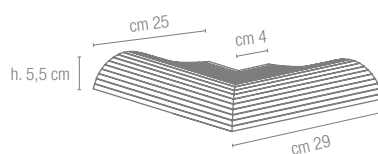

**Art. 9668 Pool Wave ▲**  
cm 25x29 - 9 7/8"x11 1/2"

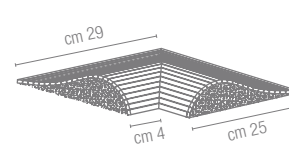

**pietra baugé** grigia

# pietra baugé

PIETRE NATIVE



**baugé grigia** cm 60x60 - 23<sup>5</sup>/<sub>8</sub>"x23<sup>5</sup>/<sub>8</sub>"

## COLORI COLOURS COULEURS FARBEN

baugé antracite



baugé grigia



baugé beige



baugé bianca

Caratteristiche tecniche ed estetiche a pagina: Technical and aesthetics features on page:  
Caractéristiques techniques et esthétiques à la page : Technische und ästhetische Eigenschaften auf Seite: **438**









# pietra baugé

PIETRE NATIVE



mosaico baugé antracite 10x10 cm 30x30 - 11<sup>3</sup>/<sub>4</sub>"x11<sup>3</sup>/<sub>4</sub>",  
esagono baugé antracite cm 30x51,9 - 11<sup>3</sup>/<sub>4</sub>"x20<sup>3</sup>/<sub>8</sub>"

## FORMATI SIZES FORMATS FORMATE

Formati Sizes Formats Formate					
	<b>cm 30x60</b> 11 <sup>3</sup> / <sub>4</sub> "x23 <sup>5</sup> / <sub>8</sub> "	<b>cm 60x60</b> 23 <sup>5</sup> / <sub>8</sub> "x23 <sup>5</sup> / <sub>8</sub> "	<b>cm 60x60</b> 23 <sup>5</sup> / <sub>8</sub> "x23 <sup>5</sup> / <sub>8</sub> "	<b>cm 90x90</b> 35 <sup>3</sup> / <sub>8</sub> "x35 <sup>3</sup> / <sub>8</sub> "	<b>cm 90x90</b> 35 <sup>3</sup> / <sub>8</sub> "x35 <sup>3</sup> / <sub>8</sub> "
Superfici Surfaces Surfaces Oberflächen	●	●	●	●	●
	mm 10 mm 9 mm 9*	mm 10	mm 20	mm 10	mm 20



Accentuata  
Accentuated  
Importante  
Starke

Vedi pagina: See page: Voir page : Siehe Seite: **448**

● Naturale Matt Naturelle Matt **R10 A+B**  
● Grip **R11 A+B+C**

Rettificate in un unico calibro Rectified version in a single caliber Rectifiés en un unique calibre Boden Sie in einem einzigen Kaliber

\* Non rettificato Unrectified Non rectifié Nicht kalibriert

Caratteristiche tecniche e imballi a pagina: Technical features and packing on page:

Caractéristiques techniques et emballages à la page: Technische Eigenschaften und Verpackungen auf Seite: **438**

## PEZZI SPECIALI TRIMS ACCESSOIRES FORMSTÜCKE

▲ 2pcs  45°

**Battiscopa Bullnose**  
**Plinthe à bord arrondi**  
**Stehsockel**  
cm 9x60 - 3<sup>1</sup>/<sub>2</sub>"x23<sup>5</sup>/<sub>8</sub>"  
cm 9x90 - 3<sup>1</sup>/<sub>2</sub>"x35<sup>3</sup>/<sub>8</sub>"



**Gradino Step tread**  
**Nez de marche**  
**Stufenplatte**  
cm 30x60 - 11<sup>3</sup>/<sub>4</sub>"x23<sup>5</sup>/<sub>8</sub>"

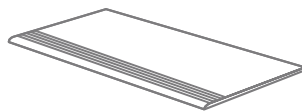

**Gradone (assemblato)**  
cm 60x33 - 23<sup>5</sup>/<sub>8</sub>"x13"

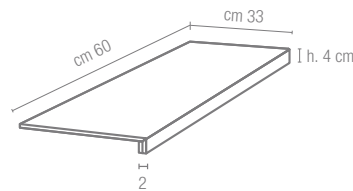

**Angolare (assemblato)**  
cm 60x33 - 23<sup>5</sup>/<sub>8</sub>"x13"

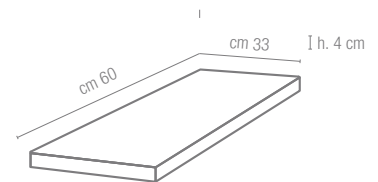

**Art. 9550**  
cm 33x60 - 13"x23<sup>5</sup>/<sub>8</sub>"

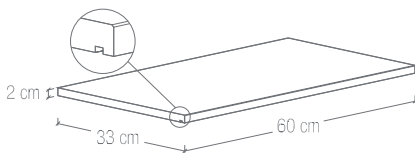

**Art. 9557** ▲  
cm 60x60 - 23<sup>5</sup>/<sub>8</sub>"x23<sup>5</sup>/<sub>8</sub>"

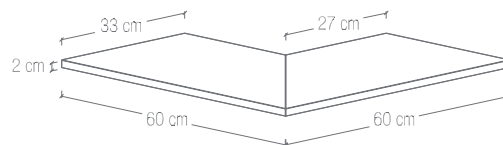

**Art. 9558** ▲  
cm 60x60 - 23<sup>5</sup>/<sub>8</sub>"x23<sup>5</sup>/<sub>8</sub>"

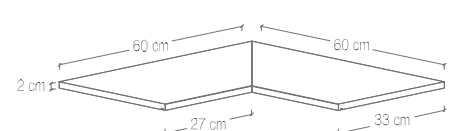

**Griglia Art. 9885**  
cm 13x40x2 - 5<sup>1</sup>/<sub>8</sub>"x15<sup>3</sup>/<sub>4</sub>" x<sup>3</sup>/<sub>4</sub>"



**Griglia angolare Art. 9886** ▲  
cm 13x40x2 - 5<sup>1</sup>/<sub>8</sub>"x15<sup>3</sup>/<sub>4</sub>" x<sup>3</sup>/<sub>4</sub>"

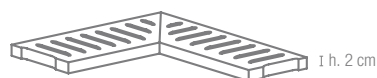

DECORI DECORS DÉCORS DEKORE

# pietra baugé

PIETRE NATIVE

mosaico 6x6\*



**cm 30x30 - 11<sup>3</sup>/<sub>4</sub>"x11<sup>3</sup>/<sub>4</sub>"**  
 tessera **cm 6x6 - 2<sup>3</sup>/<sub>8</sub>"x2<sup>3</sup>/<sub>8</sub>"**  
*su rete on net sur trame auf Netz*

mosaico 10x10\*



**cm 30x30 - 11<sup>3</sup>/<sub>4</sub>"x11<sup>3</sup>/<sub>4</sub>"**  
 tessera **cm 10x10 - 4"x4"**  
*su rete on net sur trame auf Netz*

esagono\*



**cm 30x51,9 - 11<sup>3</sup>/<sub>4</sub>"x20<sup>3</sup>/<sub>8</sub>"**

\* Disponibile in tutti i colori della serie Available in all the colours of the series Disponible dans tous les couleurs de la série Verfügbar in allen Farben



**baugé bianca cm 60x60 - 23<sup>5</sup>/<sub>8</sub>"x23<sup>5</sup>/<sub>8</sub>"**,  
**mosaico 10x10 baugé bianca cm 30x30 - 11<sup>3</sup>/<sub>4</sub>"x11<sup>3</sup>/<sub>4</sub>"**

**pietre di sardegna** cala luna

# pietre di sardegna

PIETRE NATIVE



**cala luna** cm 45x90 - 17<sup>3</sup>/<sub>4</sub>"x35<sup>3</sup>/<sub>8</sub>"

## COLORI COLOURS COULEURS FARBEN

tavolara



caprera



punta molarà



cala luna



stintino



porto cervo

Caratteristiche tecniche ed estetiche a pagina: Technical and aesthetics features on page:  
Caractéristiques techniques et esthétiques à la page : Technische und ästhetische Eigenschaften auf Seite: **438**

# pietre di sardegna









PIETRE NATIVE

porto rotondo

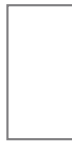
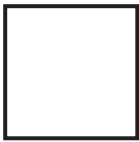

porto rotondo cm 90x90 - 35<sup>3</sup>/<sub>8</sub>"x35<sup>3</sup>/<sub>8</sub>"

## FORMATI SIZES FORMATS FORMATE

					
Formati Sizes Formats Formate	<b>cm 30x30</b> 11 <sup>3</sup> / <sub>4</sub> "x11 <sup>3</sup> / <sub>4</sub> "	<b>cm 15x60</b> 5 <sup>7</sup> / <sub>8</sub> "x23 <sup>5</sup> / <sub>8</sub> "	<b>cm 30x60</b> 11 <sup>3</sup> / <sub>4</sub> "x23 <sup>5</sup> / <sub>8</sub> "	<b>cm 60x60</b> 23 <sup>5</sup> / <sub>8</sub> "x23 <sup>5</sup> / <sub>8</sub> "	<b>cm 60x60</b> 23 <sup>5</sup> / <sub>8</sub> "x23 <sup>5</sup> / <sub>8</sub> "
Tavolara	● ●	● ●	● ●	● ● ●	●
Caprera	● ●	● ●	● ●	● ● ●	●
Punta Molara	● ●	● ●	● ●	● ● ●	●
Porto Rotondo	● ●	● ●	● ●	● ● ●	●
Cala Luna	● ●	● ●	● ●	● ● ●	●
Stintino	● ●	● ●	● ●	● ● ●	●
Porto Cervo	● ●	● ●	● ●	● ● ●	●
 	mm 9	mm 9	mm 10 mm 9	mm 10	mm 20
					
Formati Sizes Formats Formate	<b>cm 45x90</b> 17 <sup>3</sup> / <sub>4</sub> "x35 <sup>3</sup> / <sub>8</sub> "	<b>cm 90x90</b> 35 <sup>3</sup> / <sub>8</sub> "x35 <sup>3</sup> / <sub>8</sub> "	<b>cm 90x90</b> 35 <sup>3</sup> / <sub>8</sub> "x35 <sup>3</sup> / <sub>8</sub> "	<b>cm 60x120</b> 23 <sup>5</sup> / <sub>8</sub> "x47 <sup>1</sup> / <sub>4</sub> "	<b>cm 60x120</b> 23 <sup>5</sup> / <sub>8</sub> "x47 <sup>1</sup> / <sub>4</sub> "
Tavolara	● ●	● ●	●	● ●	●
Caprera	● ●	● ●	●	● ●	●
Punta Molara	● ●	● ●	●	● ●	●
Porto Rotondo	● ●	● ●	●	● ●	●
Cala Luna	● ●	● ●	●	● ●	●
Stintino	● ●	● ●	●	● ●	●
Porto Cervo	● ●	● ●	●	● ●	●
 	mm 10	mm 10	mm 20	mm 10	mm 20



Accentuata  
Accentuata  
Importante  
Starke

Vedi pagina: See page: Voir page : Siehe Seite: **448**

● Naturale Matt Naturelle Matt **R10**  
● Lappata  
● Grip **R11 A+B**

Rettificate in un unico calibro Rectified version in a single caliber Rectifiés en un unique calibre Boden Sie in einem einzigen Kaliber

Nel caso di combinazioni di formati di spessori diversi, specificarlo espressamente nell'ordine Please specify in your order if you wish to purchase formats including more than one thickness  
Prière de spécifier dans votre commande si vous souhaitez acheter des formats avec différentes épaisseurs Bitte weisen Sie im Bestellungsformular ausdrücklich darauf hin, wenn Sie  
Formatkombinationen mit verschiedenen Stärken wünschen

Caratteristiche tecniche e imballi a pagina: Technical features and packing on page: Caractéristiques techniques et emballages à la page: Technische Eigenschaften und Verpackungen auf Seite: **438**



K Grandi Lastre K<sub>ontinua</sub>  
 K<sub>ontinua</sub> Big Slabs  
 Grandes Dalles K<sub>ontinua</sub>  
 K<sub>ontinua</sub> große Platten

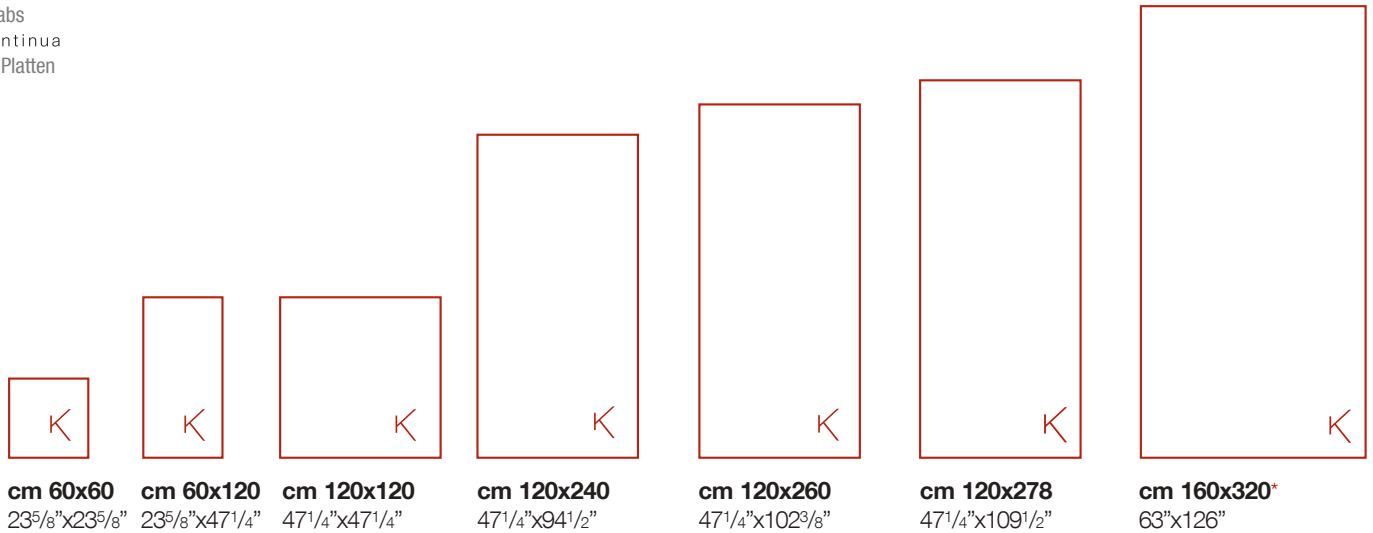

Tavolara			●	●	●		
Caprera	● ●	● ●	●	●	●	●	●
Punta Molara	● ●	● ●	●	●	●	●	
Porto Rotondo	● ●	● ●	●	●	●	●	●
Cala Luna			●	●	●		
Stintino							
Porto Cervo	● ●	● ●	●	●	●		
	mm 4,9	mm 4,9	mm 10 mm 6,5	mm 6,5	mm 6,5	mm 6,5	mm 12

\* Non rettificato Not rectified Non rectifié Nicht rektifizierte

## PEZZI SPECIALI TRIMS ACCESSOIRES FORMSTÜCKE

▲ 2pcs 45°

**Battiscopa Bullnose**  
 Plinthe à bord arrondi  
 Stehsockel  
 cm 9x30 - 3<sup>1</sup>/<sub>2</sub>"x11<sup>3</sup>/<sub>4</sub>"  
 cm 9x45 - 3<sup>1</sup>/<sub>2</sub>"x17<sup>3</sup>/<sub>4</sub>"  
 cm 9x60 - 3<sup>1</sup>/<sub>2</sub>"x23<sup>5</sup>/<sub>8</sub>"  
 cm 9x90 - 3<sup>1</sup>/<sub>2</sub>"x35<sup>3</sup>/<sub>8</sub>"

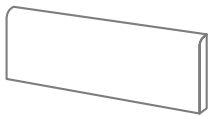

**Gradino Step tread**  
 Nez de marche  
 Stufenplatte  
 cm 30x30 - 11<sup>3</sup>/<sub>4</sub>"x11<sup>3</sup>/<sub>4</sub>"  
 cm 45x45 - 17<sup>3</sup>/<sub>4</sub>"x17<sup>3</sup>/<sub>4</sub>"  
 cm 30x60 - 11<sup>3</sup>/<sub>4</sub>"x23<sup>5</sup>/<sub>8</sub>"  
 cm 30x120 - 11<sup>3</sup>/<sub>4</sub>"x47<sup>1</sup>/<sub>4</sub>"

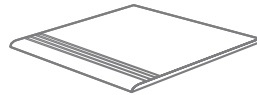

**Gradone (assemblato)**  
 cm 120x33 - 47<sup>1</sup>/<sub>4</sub>"x13"

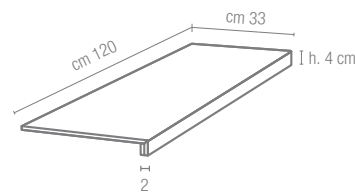

**Angolare (assemblato)**  
 cm 120x33 - 47<sup>1</sup>/<sub>4</sub>"x13"

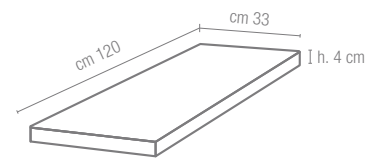

**Art. 9550**  
 cm 33x60 - 13"x23<sup>5</sup>/<sub>8</sub>"

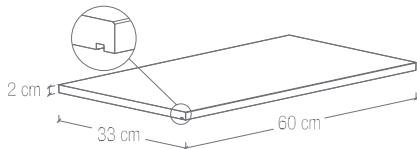

**Art. 9557 ▲**  
 cm 60x60 - 23<sup>5</sup>/<sub>8</sub>"x23<sup>5</sup>/<sub>8</sub>"

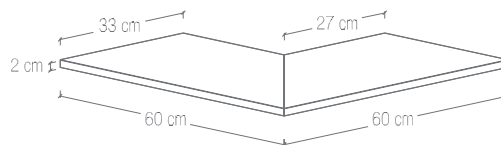

**Art. 9558 ▲**  
 cm 60x60 - 23<sup>5</sup>/<sub>8</sub>"x23<sup>5</sup>/<sub>8</sub>"

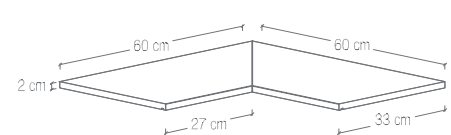

**Griglia Art. 9885**  
 cm 13x40x2 - 5<sup>1</sup>/<sub>8</sub>"x15<sup>3</sup>/<sub>4</sub>" x<sup>3</sup>/<sub>4</sub>"

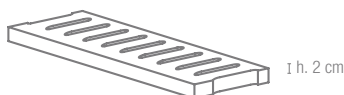

**Griglia angolare Art. 9886 ▲**  
 cm 13x40x2 - 5<sup>1</sup>/<sub>8</sub>"x15<sup>3</sup>/<sub>4</sub>" x<sup>3</sup>/<sub>4</sub>"

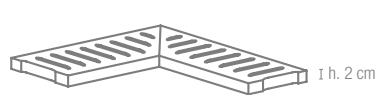

## SUPERFICI SURFACES SURFACES OBERFLÄCHEN

**lappata**

**naturale matt  
naturelle matt  
R10 A**

**grip  
R11 A+B**

DECORI DECORS  
DÉCORS DEKORE

# pietre di sardegna

PIETRE NATIVE

mosaico 3x3\*

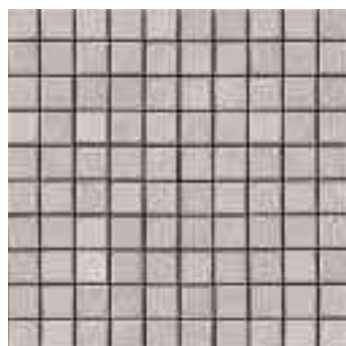

**cm 30x30** - 11<sup>3</sup>/<sub>4</sub>"x11<sup>3</sup>/<sub>4</sub>"  
tessera **cm 3x3** - 1<sup>1</sup>/<sub>8</sub>"x1<sup>1</sup>/<sub>8</sub>"  
*su rete on net sur trame auf Netz*

mosaico 6x6\*



**cm 30x30** - 11<sup>3</sup>/<sub>4</sub>"x11<sup>3</sup>/<sub>4</sub>"  
tessera **cm 6x6** - 2<sup>3</sup>/<sub>8</sub>"x2<sup>3</sup>/<sub>8</sub>"  
*su rete on net sur trame auf Netz*

▽ mm 10    ▽ KONTINUA mm 6,5

composizione A\*



**cm 30x60** - 11<sup>3</sup>/<sub>4</sub>"x23<sup>5</sup>/<sub>8</sub>"  
*su rete on net sur trame auf Netz*

\* Disponibile in tutti i colori della serie, superficie naturale e lappata Available in all the colours of the series, matt and "lappata" surface  
Disponibile dans toutes les couleurs de la série, surface naturelle et "lappata" Verfügbar in allen Farben, matte und "lappata" Oberfläche

Complementi in acciaio e alluminio a pagina: Technical features on page: Caractéristiques techniques à la page: Technische eigenschaften auf Seite: **449**

## DECORI DECORS DÉCORS DEKORE

## diagonal



cm 120x240 47<sup>1</sup>/<sub>4</sub>"x 94<sup>1</sup>/<sub>2</sub>"

 Kontinua mm 6,5

Decoro abbinabile con  
 le collezioni Pietre di Paragone,  
 Pietre di Sardegna e Marmoker  
 Decor matching the Pietre di  
 Paragone, Pietre di Sardegna  
 and Marmoker collections  
 Décor pouvant être associé aux  
 collections Pietre di Paragone,  
 Pietre di Sardegna et Marmoker  
 Dekor kombinierbar mit den  
 Kollektionen Pietre di Paragone,  
 Pietre di Sardegna und Marmoker



diagonal cm 120x240 - 47<sup>1</sup>/<sub>4</sub>"x94<sup>1</sup>/<sub>2</sub>"

# pietre di sardegna

PIETRE NATIVE

optical



cm 120x240 47<sup>1</sup>/<sub>4</sub>"x 94<sup>1</sup>/<sub>2</sub>"

 Kontinua mm 6,5

Decoro abbinabile con  
le collezioni Pietre di Paragone,  
Pietre di Sardegna e Marmoker  
Decor matching the Pietre di  
Paragone, Pietre di Sardegna  
and Marmoker collections  
Décor pouvant être associé aux  
collections Pietre di Paragone,  
Pietre di Sardegna et Marmoker  
Dekor kombinierbar mit den  
Kollektionen Pietre di Paragone,  
Pietre di Sardegna und Marmoker



optical cm 120x240 - 47<sup>1</sup>/<sub>4</sub>"x94<sup>1</sup>/<sub>2</sub>"

## DECORI DECORS DÉCORS DEKORE

## round square



cm 120x240 47<sup>1</sup>/<sub>4</sub>"x 94<sup>1</sup>/<sub>2</sub>"

▼  
▲ Kontinua mm 6,5

Decoro abbinabile con  
le collezioni Pietre di Paragone,  
Pietre di Sardegna e Marmoker  
Decor matching the Pietre di  
Paragone, Pietre di Sardegna  
and Marmoker collections  
Décor pouvant être associé aux  
collections Pietre di Paragone,  
Pietre di Sardegna et Marmoker  
Dekor kombinierbar mit den  
Kollektionen Pietre di Paragone,  
Pietre di Sardegna und Marmoker



round square cm 120x240 - 47<sup>1</sup>/<sub>4</sub>"x94<sup>1</sup>/<sub>2</sub>"

# pietre di sardegna

PIETRE NATIVE

golden paint

cm 120x240 47<sup>1</sup>/<sub>4</sub>"x 94<sup>1</sup>/<sub>2</sub>"

 Kontinua mm 6,5

Decoro abbinabile con  
le collezioni Pietre di Paragone,  
Pietre di Sardegna e Marmoker  
Decor matching the Pietre di  
Paragone, Pietre di Sardegna  
and Marmoker collections  
Décor pouvant être associé aux  
collections Pietre di Paragone,  
Pietre di Sardegna et Marmoker  
Dekor kombinierbar mit den  
Kollektionen Pietre di Paragone,  
Pietre di Sardegna und Marmoker

golden paint cm 120x240 - 47<sup>1</sup>/<sub>4</sub>"x94<sup>1</sup>/<sub>2</sub>"

**stonewash** wash brown



# stonewash

GRANITOKER



wash brown cm 30x180 - 11<sup>3</sup>/<sub>4</sub>"x70<sup>7</sup>/<sub>8</sub>"

## COLORI COLOURS COULEURS FARBEN

wash brown











wash grey



wash cream

Caratteristiche tecniche ed estetiche a pagina: Technical and aesthetics features on page:  
Caractéristiques techniques et esthétiques à la page : Technische und ästhetische Eigenschaften auf Seite: **438**

## FORMATI SIZES FORMATS FORMATE

							
Formati Sizes Formats Formate	<b>cm 60x60</b> 23 <sup>5</sup> / <sub>8</sub> "x23 <sup>5</sup> / <sub>8</sub> "	<b>cm 90x90</b> 35 <sup>3</sup> / <sub>8</sub> "x35 <sup>3</sup> / <sub>8</sub> "	<b>cm 20x120</b> 12"x47 <sup>1</sup> / <sub>4</sub> "	<b>cm 60x120</b> 23 <sup>5</sup> / <sub>8</sub> "x47 <sup>1</sup> / <sub>4</sub> "	<b>cm 22,5x180</b> 8 <sup>7</sup> / <sub>8</sub> "x70 <sup>7</sup> / <sub>8</sub> "	<b>cm 30x180</b> 11 <sup>3</sup> / <sub>4</sub> "x70 <sup>7</sup> / <sub>8</sub> "	<b>cm 90x180</b> 35 <sup>7</sup> / <sub>8</sub> "x70 <sup>7</sup> / <sub>8</sub> "
SuperficiSurfaces Surfaces Oberflächen	●	●	●	●	●	●	●
	mm 10	mm 10	mm 10	mm 10	mm 10	mm 10	mm 10



● Naturale Matt Naturelle Matt R9

Vedi pagina: See page: Voir page : Siehe Seite: **448**

Rettificate in un unico calibro Rectified version in a single caliber Rectifiés en un unique calibre Boden Sie in einem einzigen Kaliber

Caratteristiche tecniche e imballi a pagina: Technical features and packing on page: Caractéristiques techniques et emballages à la page: Technische Eigenschaften und Verpackungen auf Seite: **440**

## PEZZI SPECIALI TRIMS ACCESSOIRES FORMSTÜCKE

**Battiscopa Bullnose**  
**Plinthe à bord arrondi**  
**Stehsockel**  
cm 9x90 - 3<sup>1</sup>/<sub>2</sub>"x35<sup>3</sup>/<sub>8</sub>"  
cm 9x60 - 3<sup>1</sup>/<sub>2</sub>"x23<sup>5</sup>/<sub>8</sub>"



**Gradino Step tread**  
**Nez de marche**  
**Stufenplatte**  
cm 30x90 - 11<sup>3</sup>/<sub>4</sub>"x35<sup>3</sup>/<sub>8</sub>"  
cm 30x60 - 11<sup>3</sup>/<sub>4</sub>"x23<sup>5</sup>/<sub>8</sub>"

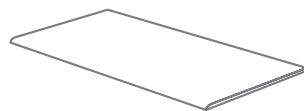

**Gradone (assemblato)**  
cm 90x33 - 35<sup>3</sup>/<sub>8</sub>"x13"  
cm 120x33 - 47<sup>1</sup>/<sub>4</sub>"x13"

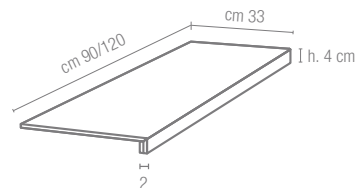

**Angolare (assemblato)**  
cm 90x33 - 35<sup>3</sup>/<sub>8</sub>"x13"  
cm 120x33 - 35<sup>3</sup>/<sub>8</sub>"x47<sup>1</sup>/<sub>4</sub>"

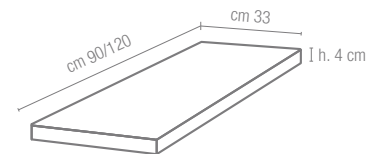

## DECORI DECORS DÉCORS DEKORE

**mosaico 6x6\***



**cm 30x30 - 11<sup>3</sup>/<sub>4</sub>"x11<sup>3</sup>/<sub>4</sub>"**  
tessera **cm 6x6 - 2<sup>3</sup>/<sub>8</sub>"x2<sup>3</sup>/<sub>8</sub>"**  
*su rete on net sur trame auf Netz*

\* Disponibile in tutti i colori della serie  
Available in all the colours of the series  
Disponibile dans tous les couleurs de la série  
Verfügbar in allen Farben

**terre toscane** san casciano

# terre toscane

PIETRE NATIVE



**san casciano** cm 30x60 - 11<sup>3</sup>/<sub>4</sub>"x23<sup>5</sup>/<sub>8</sub>"

## COLORI COLOURS COULEURS FARBEN

montepulciano



gaiole



greve



verrazzano



monteriggioni



san casciano

Caratteristiche tecniche ed estetiche a pagina: Technical and aesthetics features on page:  
Caractéristiques techniques et esthétiques à la page : Technische und ästhetische Eigenschaften auf Seite: **438**

SUPERFICI SURFACES  
SURFACES OBERFLÄCHEN

**terre toscane**

PIETRE NATIVE

**lappata**

**naturale matt  
naturelle matt  
R9**

## FORMATI SIZES FORMATS FORMATE

Formati Sizes Formats Formate	<b>cm 30x30</b> 11 <sup>3</sup> / <sub>4</sub> "x11 <sup>3</sup> / <sub>4</sub> "	<b>cm 30x60</b> 11 <sup>3</sup> / <sub>4</sub> "x23 <sup>5</sup> / <sub>8</sub> "	<b>cm 60x60</b> 23 <sup>5</sup> / <sub>8</sub> "x23 <sup>5</sup> / <sub>8</sub> "	<b>cm 45x90</b> 17 <sup>3</sup> / <sub>4</sub> "x35 <sup>3</sup> / <sub>8</sub> "	<b>cm 60x120</b> 23 <sup>5</sup> / <sub>8</sub> "x47 <sup>1</sup> / <sub>4</sub> "	<b>cm 120x120</b> 47 <sup>1</sup> / <sub>4</sub> "x47 <sup>1</sup> / <sub>4</sub> "	<b>cm 37,5x75,5</b> 14 <sup>3</sup> / <sub>4</sub> "x29 <sup>3</sup> / <sub>4</sub> "	<b>cm 75,5x75,5</b> 29 <sup>3</sup> / <sub>4</sub> "x29 <sup>3</sup> / <sub>4</sub> "	<b>cm 75,5x151</b> 29 <sup>3</sup> / <sub>4</sub> "x59 <sup>1</sup> / <sub>2</sub> "
Superfici Surfaces Surfaces Oberflächen	●	● ●	● ●	●	●	●	●	●	●
	mm 9	mm 10 mm 9	mm 10	mm 10	mm 10	mm 10	mm 10	mm 10	mm 10



Vedi pagina: See page: Voir page : Siehe Seite: **448**

- Naturale Matt Naturelle Matt **R9**
- Lappata

Rettificate in un unico calibro Rectified version in a single caliber Rectifiés en un unique calibre Boden Sie in einem einzigen Kaliber

Nel caso di combinazioni di formati di spessori diversi, specificarlo espressamente nell'ordine

Please specify in your order if you wish to purchase formats including more than one thickness

Prière de spécifier dans votre commande si vous souhaitez acheter des formats avec différentes épaisseurs

Bitte weisen Sie im Bestellungsformular ausdrücklich darauf hin, wenn Sie Formatkombinationen mit verschiedenen Stärken wünschen

Caratteristiche tecniche e imballi a pagina: Technical features and packing on page:

Caractéristiques techniques et emballages à la page: Technische Eigenschaften und Verpackungen auf Seite: **438**

## PEZZI SPECIALI TRIMS ACCESSOIRES FORMSTÜCKE

### Battiscopa Bullnose Plinthe à bord arrondi Stehsockel

cm 7x75,5 - 2<sup>3</sup>/<sub>4</sub>"x35<sup>3</sup>/<sub>8</sub>"

cm 9x30 - 3<sup>1</sup>/<sub>2</sub>"x11<sup>3</sup>/<sub>4</sub>"

cm 9x60 - 3<sup>1</sup>/<sub>2</sub>"x23<sup>5</sup>/<sub>8</sub>"

cm 9x90 - 3<sup>1</sup>/<sub>2</sub>"x35<sup>3</sup>/<sub>8</sub>"

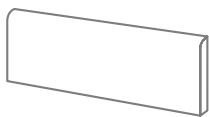

### Gradino Step tread Nez de marche Stufenplatte

cm 30x30 - 11<sup>3</sup>/<sub>4</sub>"x11<sup>3</sup>/<sub>4</sub>"

cm 30x60 - 11<sup>3</sup>/<sub>4</sub>"x23<sup>5</sup>/<sub>8</sub>"

cm 30x120 - 11<sup>3</sup>/<sub>4</sub>"x47<sup>1</sup>/<sub>4</sub>"

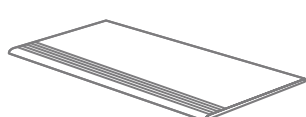

### Gradone (assemblato) cm 120x33 - 47<sup>1</sup>/<sub>4</sub>"x13"

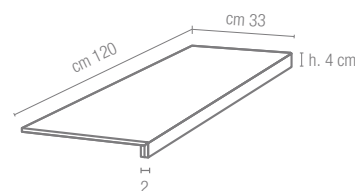

### Angolare (assemblato) cm 120x33 - 47<sup>1</sup>/<sub>4</sub>"x13"

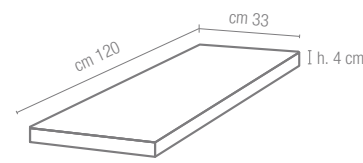



DECORI DECORS DÉCORS DEKORE

# terre toscane

PIETRE NATIVE

mosaico terre toscane A



**cm 30x30** -  $11\frac{3}{4}'' \times 11\frac{3}{4}''$   
 tessera **cm 2,2x2,2** -  $\frac{7}{8}'' \times \frac{7}{8}''$   
*su rete on net sur trame auf Netz*  
**san casciano**  
 naturale matt naturelle Matt

mosaico terre toscane B



**cm 30x30** -  $11\frac{3}{4}'' \times 11\frac{3}{4}''$   
 tessera **cm 2,2x2,2** -  $\frac{7}{8}'' \times \frac{7}{8}''$   
*su rete on net sur trame auf Netz*  
**verrazzano**  
 naturale matt naturelle Matt

mosaico 3x3\*



**cm 30x30** -  $11\frac{3}{4}'' \times 11\frac{3}{4}''$   
 tessera **cm 3x3** -  $1\frac{1}{8}'' \times 1\frac{1}{8}''$   
*su rete on net sur trame auf Netz*

mosaico 6x6\*



**cm 30x30** -  $11\frac{3}{4}'' \times 11\frac{3}{4}''$   
 tessera **cm 6x6** -  $2\frac{3}{8}'' \times 2\frac{3}{8}''$   
*su rete on net sur trame auf Netz*

composizione A\*



**cm 30x60** -  $11\frac{3}{4}'' \times 23\frac{5}{8}''$   
*su rete on net sur trame auf Netz*  
 naturale matt naturelle Matt

\* Disponibile in tutti i colori della serie, superficie naturale e lappata Available in all the colours of the series, matt and "lappata" surface Disponible dans toutes les couleurs de la série, surface naturelle et "lappata" Verfügbar in allen Farben, matte und "lappata" Oberfläche



# pietre etrusche

PIETRE NATIVE



tuscania cm 60x120 - 23<sup>5</sup>/<sub>8</sub>"x47<sup>1</sup>/<sub>4</sub>"

## COLORI COLOURS COULEURS FARBEN

**manciano**



**sovana**



**vulci**



**pitigliano**



**tuscania**



**saturnia**

Caratteristiche tecniche ed estetiche a pagina: Technical and aesthetics features on page:  
Caractéristiques techniques et esthétiques à la page : Technische und ästhetische Eigenschaften auf Seite: **438**

# pietre etrusche

PIETRE NATIVE

capalbio



paestum



tarquinia

## FORMATI SIZES FORMATS FORMATE

Formati Sizes Formats Formate	<b>cm 30x30</b> 11 <sup>3</sup> / <sub>4</sub> "x11 <sup>3</sup> / <sub>4</sub> "	<b>cm 45x45</b> 17 <sup>3</sup> / <sub>4</sub> "x17 <sup>3</sup> / <sub>4</sub> "	<b>cm 15x60</b> 5 <sup>7</sup> / <sub>8</sub> "x23 <sup>5</sup> / <sub>8</sub> "	<b>cm 30x60</b> 11 <sup>3</sup> / <sub>4</sub> "x23 <sup>5</sup> / <sub>8</sub> "	<b>cm 60x60</b> 23 <sup>5</sup> / <sub>8</sub> "x23 <sup>5</sup> / <sub>8</sub> "	<b>cm 60x60</b> 23 <sup>5</sup> / <sub>8</sub> "x23 <sup>5</sup> / <sub>8</sub> "	<b>cm 45x90</b> 17 <sup>3</sup> / <sub>4</sub> "x35 <sup>3</sup> / <sub>8</sub> "	<b>cm 60x120</b> 23 <sup>5</sup> / <sub>8</sub> "x47 <sup>1</sup> / <sub>4</sub> "	<b>cm 60x120</b> 23 <sup>5</sup> / <sub>8</sub> "x47 <sup>1</sup> / <sub>4</sub> "
Superfici Surfaces Surfaces Oberflächen	●	●	●	● ●	● ●	● ●	● ●	● ●	● ●
	mm 8*	mm 9*	mm 9	mm 10 mm 9 mm 9*	mm 10	mm 4,9**	mm 10	mm 10	mm 4,9**



Leggera  
Minimal  
Légère  
Leichte

Vedi pagina: See page: Voir page : Siehe Seite: **448**

● Naturale Matt Naturelle Matt **R9**  
● Lappata

Rettificate in un unico calibro Rectified version in a single caliber Rectifiés en un unique calibre Boden Sie in einem einzigen Kaliber

\* Solo naturale, versione non rettificata Only matt, not rectified version Seulement naturel, version non rectifiée Nur matt, in der nicht rektifizierte Version und in die Farben: **Capalbio, Saturnia, Sovana, Tuscania, Paestum, Manciano, Tarquinia**

\*\* Solo nei colori Only the colours: Seulement les couleurs: Nur farben: **Saturnia, Tuscania, Paestum, Manciano**

Nel caso di combinazioni di formati di spessori diversi, specificarlo espressamente nell'ordine  
Please specify in your order if you wish to purchase formats including more than one thickness  
Prière de spécifier dans votre commande si vous souhaitez acheter des formats avec différentes épaisseurs  
Bitte weisen Sie im Bestellungsformular ausdrücklich darauf hin, wenn Sie Formatkombinationen mit verschiedenen Stärken wünschen

Caratteristiche tecniche e imballi a pagina: Technical features and packing on page:  
Caractéristiques techniques et emballages à la page: Technische Eigenschaften und Verpackungen auf Seite: **438**

## PEZZI SPECIALI TRIMS ACCESSOIRES FORMSTÜCKE

**Battiscopa Bullnose**  
**Plinthe à bord arrondi**  
**Stehsockel**  
cm 9x30 - 3<sup>1</sup>/<sub>2</sub>"x11<sup>3</sup>/<sub>4</sub>"  
cm 9x45 - 3<sup>1</sup>/<sub>2</sub>"x17<sup>3</sup>/<sub>4</sub>"  
cm 9x60 - 3<sup>1</sup>/<sub>2</sub>"x23<sup>5</sup>/<sub>8</sub>"



**Gradino Step tread**  
**Nez de marche Stufenplatte**  
cm 30x30 - 11<sup>3</sup>/<sub>4</sub>"x11<sup>3</sup>/<sub>4</sub>"  
cm 45x45 - 17<sup>3</sup>/<sub>4</sub>"x17<sup>3</sup>/<sub>4</sub>"  
cm 30x60 - 11<sup>3</sup>/<sub>4</sub>"x23<sup>5</sup>/<sub>8</sub>"  
cm 30x120 - 11<sup>3</sup>/<sub>4</sub>"x47<sup>1</sup>/<sub>4</sub>"

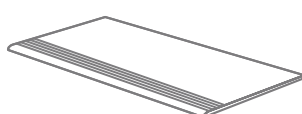

**Gradone (assemblato)**  
cm 120x33 - 47<sup>1</sup>/<sub>4</sub>"x13"

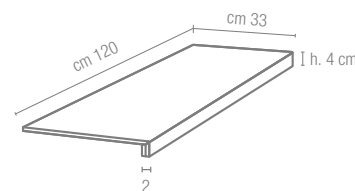

**Angolare (assemblato)**  
cm 120x33 - 47<sup>1</sup>/<sub>4</sub>"x13"

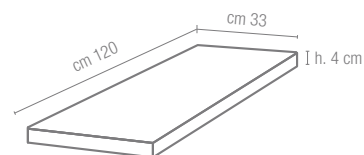

SUPERFICI SURFACES  
SURFACES OBERFLÄCHEN

# pietre etrusche

PIETRE NATIVE

**lappata**

**naturale matt**  
**naturelle matt**  
**R9**

**basaltina** linosa



# basaltina

PIETRE NATIVE



linosa cm 30x60 - 11<sup>3</sup>/<sub>4</sub>"x23<sup>5</sup>/<sub>8</sub>"

## COLORI COLOURS COULEURS FARBEN

vulcano



linosa



lipari



stromboli

pantelleria







ischia

Caratteristiche tecniche ed estetiche a pagina: Technical and aesthetics features on page:  
Caractéristiques techniques et esthétiques à la page : Technische und ästhetische Eigenschaften auf Seite: **438**

## FORMATI SIZES FORMATS FORMATE

# basaltina

PIETRE NATIVE

Formati Sizes Formats Formate					
	<b>cm 30x30</b> 11 <sup>3</sup> / <sub>4</sub> "x11 <sup>3</sup> / <sub>4</sub> "	<b>cm 30x60</b> 11 <sup>3</sup> / <sub>4</sub> "x23 <sup>5</sup> / <sub>8</sub> "	<b>cm 60x60</b> 23 <sup>5</sup> / <sub>8</sub> "x23 <sup>5</sup> / <sub>8</sub> "	<b>cm 45x90</b> 17 <sup>3</sup> / <sub>4</sub> "x35 <sup>3</sup> / <sub>8</sub> "	<b>cm 60x120</b> 23 <sup>5</sup> / <sub>8</sub> "x47 <sup>1</sup> / <sub>4</sub> "
Superfici Surfaces Surfaces Oberflächen	●	●	●	●	●
	mm 9	mm 10 mm 9	mm 10	mm 10	mm 10



Media  
Medium  
Moderée  
Mittlere

Vedi pagina: See page: Voir page : Siehe Seite: **448**

Rettificate in un unico calibro Rectified version in a single caliber Rectifiés en un unique calibre Boden Sie in einem einzigen Kaliber

Specificare espressamente nell'ordine eventuali combinazioni di spessori diversi Specify expressly in the order any combinations of different thicknesses

Préciser expressément dans l'ordre toutes les combinaisons de différentes épaisseurs Geben Sie ausdrücklich in der Reihenfolge an beliebige Kombinationen der verschiedenen Stärken

Caratteristiche tecniche e imballi a pagina: Technical features and packing on page: Caractéristiques techniques et emballages à la page: Technische Eigenschaften und Verpackungen auf Seite: **438**

## PEZZI SPECIALI TRIMS ACCESSOIRES FORMSTÜCKE

**Battiscopa Bullnose**  
**Plinthe à bord arrondi**  
**Stehsockel**

**cm 9x30** - 3<sup>1</sup>/<sub>2</sub>"x11<sup>3</sup>/<sub>4</sub>"

**cm 9x45** - 3<sup>1</sup>/<sub>2</sub>"x17<sup>3</sup>/<sub>4</sub>"

**cm 9x60** - 3<sup>1</sup>/<sub>2</sub>"x23<sup>5</sup>/<sub>8</sub>"

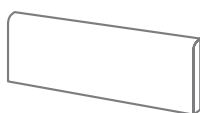

**Gradino Step tread**  
**Nez de marche Stufenplatte**

**cm 30x30** - 11<sup>3</sup>/<sub>4</sub>"x11<sup>3</sup>/<sub>4</sub>"

**cm 30x60** - 11<sup>3</sup>/<sub>4</sub>"x23<sup>5</sup>/<sub>8</sub>"

**cm 30x120** - 11<sup>3</sup>/<sub>4</sub>"x47<sup>1</sup>/<sub>4</sub>"

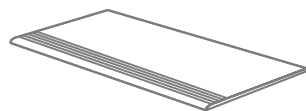

**Gradone (assemblato)**  
**cm 120x33** - 47<sup>1</sup>/<sub>4</sub>"x13"

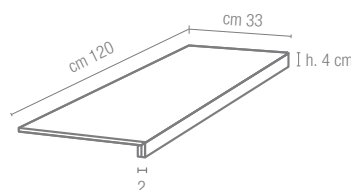

**Angolare (assemblato)**  
**cm 120x33** - 47<sup>1</sup>/<sub>4</sub>"x13"

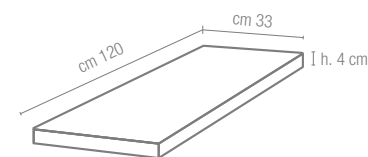

## DECORI DECORS DÉCORS DEKORE

**mosaico 6x6\***



**cm 30x30** - 11<sup>3</sup>/<sub>4</sub>"x11<sup>3</sup>/<sub>4</sub>"  
tessera **cm 6x6** - 2<sup>3</sup>/<sub>8</sub>"x2<sup>3</sup>/<sub>8</sub>"  
*su rete on net sur trame auf Netz*

**mosaico 3x3\***

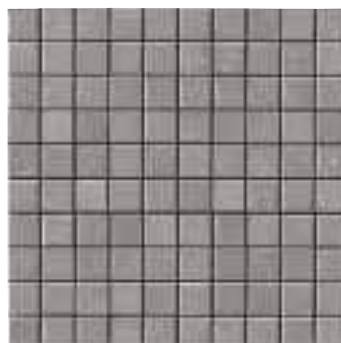

**cm 30x30** - 11<sup>3</sup>/<sub>4</sub>"x11<sup>3</sup>/<sub>4</sub>"  
tessera **cm 3x3** - 1<sup>1</sup>/<sub>8</sub>"x1<sup>1</sup>/<sub>8</sub>"  
*su rete on net sur trame auf Netz*

\* Disponibile in tutti i colori della serie  
Available in all the colours of the series  
Disponible dans toutes les couleurs de la série  
Verfügbar in allen Farben

**kerblock** beige

# kerblock

PIETRE NATIVE



kerblock beige cm 60x60 - 23<sup>5</sup>/<sub>8</sub>"x23<sup>5</sup>/<sub>8</sub>"

## COLORI COLOURS COULEURS FARBEN

kerblock nero



kerblock piombo



kerblock beige



kerblock avorio

Caratteristiche tecniche ed estetiche a pagina: Technical and aesthetics features on page:  
Caractéristiques techniques et esthétiques à la page : Technische und ästhetische Eigenschaften auf Seite: **438**

## FORMATI SIZES FORMATS FORMATE

**kerblock**

PIETRE NATIVE

**cm 60x60**  
23<sup>5</sup>/<sub>8</sub>"x23<sup>5</sup>/<sub>8</sub>"Formati Sizes  
Formats FormateSuperfici Surfaces  
Surfaces Oberflächen

mm 20

Leggera  
Minimal  
Légère  
Leichte● Grip **R11 A+B+C**Vedi pagina: See page: Voir page : Siehe Seite: **448**

Rettificate in un unico calibro Rectified version in a single caliber Rectifiés en un unique calibre Boden Sie in einem einzigen Kaliber

Caratteristiche tecniche e imballi a pagina: Technical features and packing on page: Caractéristiques techniques et emballages à la page: Technische Eigenschaften und Verpackungen auf Seite: **438****kerblock piombo** cm 60x60 - 23<sup>5</sup>/<sub>8</sub>"x23<sup>5</sup>/<sub>8</sub>"

**titano** chambrod



# titano

GRANITOGRES



**chambrod** *bocciardata* cm 30x60 - 11<sup>3</sup>/<sub>4</sub>"x23<sup>5</sup>/<sub>8</sub>", 60x60 - 23<sup>5</sup>/<sub>8</sub>"x23<sup>5</sup>/<sub>8</sub>"

## COLORI COLOURS COULEURS FARBEN

cardoso



chambrod



caen



grigio ash



buxy

Caratteristiche tecniche ed estetiche a pagina: Technical and aesthetics features on page:  
Caractéristiques techniques et esthétiques à la page : Technische und ästhetische Eigenschaften auf Seite: **434**

## FORMATI SIZES FORMATS FORMATE

# titano

GRANITOGRES

Formati Sizes  
Formats Formate



**cm 60x60**  
23<sup>5</sup>/<sub>8</sub>"x23<sup>5</sup>/<sub>8</sub>"

Superfici Surfaces  
Surfaces Oberflächen



mm 14



Media  
Medium  
Modérée  
Mittlere

Vedi pagina: See page: Voir page : Siehe Seite: **448**

● Naturale Matt Naturelle Matt **R9**

**UPEC U4 P4S E3 C2**

Rettificate in un unico calibro Rectified version in a single caliber Rectifiés en un unique calibre Boden Sie in einem einzigen Kaliber

Caratteristiche tecniche e imballi a pagina: Technical features and packing on page: Caractéristiques techniques et emballages à la page: Technische Eigenschaften und Verpackungen auf Seite: **434**

## PEZZI SPECIALI TRIMS ACCESSOIRES FORMSTÜCKE

**Battiscopa Bullnose**  
**Plinthe à bord arrondi**  
**Stehsockel**  
**cm 9x60 - 3<sup>1</sup>/<sub>2</sub>"x23<sup>5</sup>/<sub>8</sub>"**



**grigio ash cm 60x60 - 23<sup>5</sup>/<sub>8</sub>"x23<sup>5</sup>/<sub>8</sub>"**

**ardesia** nero

# ardesia

GRANITOGRES



ardesia nero, ardesia grigio, ardesia bianco cm 30x30 - 11<sup>3</sup>/<sub>4</sub>"x11<sup>3</sup>/<sub>4</sub>"

## COLORI COLOURS COULEURS FARBEN

ardesia nero



ardesia grigio



ardesia bianco



ardesia rosso



ardesia rosa









ardesia beige

Caratteristiche tecniche ed estetiche a pagina: Technical and aesthetics features on page:  
Caractéristiques techniques et esthétiques à la page : Technische und ästhetische Eigenschaften auf Seite: **434**

## FORMATI SIZES FORMATS FORMATE

# ardesia

GRANITOGRES

Formati Sizes Formats Formate	 <b>cm 15x15</b> 57/8"x57/8"	 <b>cm 15x30</b> 57/8"x113/4"	 <b>cm 30x30</b> 113/4"x113/4"
Superfici Surfaces Surfaces Oberflächen			
	mm 8	mm 8	mm 8



Accentuata  
Accentuated  
Importante  
Starke

Vedi pagina: See page: Voir page : Siehe Seite: **448**

● Naturale Matt Naturelle Matt **R10 A+B**

Caratteristiche tecniche e imballi a pagina: Technical features and packing on page: Caractéristiques techniques et emballages à la page: Technische Eigenschaften und Verpackungen auf Seite: **434**

## PEZZI SPECIALI TRIMS ACCESSOIRES FORMSTÜCKE

**Battiscopa Bullnose**  
**Plinthe à bord arrondi**  
**Stehsockel**  
cm 9x30 - 31/2"x113/4"



**Gradino Step tread**  
**Nez de marche**  
**Stufenplatte**  
cm 30x30 - 113/4"x113/4"

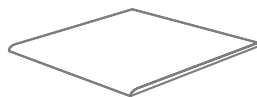

**Terminale**  
Pezzo unico Pièce unique  
Single piece Einzelstück  
cm 15x30x3,5 - 57/8"x113/4"x13/8"

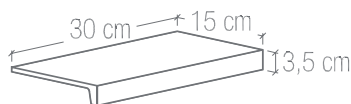

**Gradone e gradone angolare**  
cm 30x30 - 113/4"x113/4"

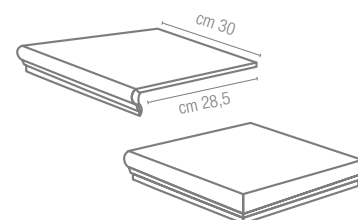

ardesia bianco cm 15x30 - 57/8"x113/4"

**lavagna** nera



# lavagna

PIETRE NATIVE



lavagna nera, lavagna bianca cm 30x60 - 11<sup>3</sup>/<sub>4</sub>"x23<sup>5</sup>/<sub>8</sub>"

## COLORI COLOURS COULEURS FARBEN

lavagna nera



lavagna grigia







lavagna bianca

Caratteristiche tecniche ed estetiche a pagina: Technical and aesthetics features on page:  
Caractéristiques techniques et esthétiques à la page : Technische und ästhetische Eigenschaften auf Seite: **438**

## FORMATI SIZES FORMATS FORMATE

lavagna

PIETRE NATIVE

Formati Sizes Formats Formate	 <b>cm 15x15</b> 5 <sup>7</sup> / <sub>8</sub> "x5 <sup>7</sup> / <sub>8</sub> "	 <b>cm 30x30</b> 11 <sup>3</sup> / <sub>4</sub> "x 11 <sup>3</sup> / <sub>4</sub> "	 <b>cm 30x60</b> 11 <sup>3</sup> / <sub>4</sub> "x23 <sup>5</sup> / <sub>8</sub> "	 <b>cm 60x60</b> 23 <sup>5</sup> / <sub>8</sub> "x23 <sup>5</sup> / <sub>8</sub> "
Superfici Surfaces Surfaces Oberflächen	●	●	●	●
	mm 9	mm 9	mm 10* mm 9	mm 10*



Leggera  
Minimal  
Légère  
Leichte

Vedi pagina: See page: Voir page : Siehe Seite: **448**

● Naturale Matt Naturelle Matt **R10 A**

\* Solo Only Seulement Nur **Lavagna nera**

Rettificate in un unico calibro Rectified version in a single caliber Rectifiés en un unique calibre Boden Sie in einem einzigen Kaliber

Nel caso di combinazioni di formati di spessori diversi, specificarlo espressamente nell'ordine Please specify in your order if you wish to purchase formats including more than one thickness  
Prière de spécifier dans votre commande si vous souhaitez acheter des formats avec différentes épaisseurs Bitte weisen Sie im Bestellungsformular ausdrücklich darauf hin, wenn Sie  
Formatkombinationen mit verschiedenen Stärken wünschen

Caratteristiche tecniche e imballi a pagina: Technical features and packing on page: Caractéristiques techniques et emballages à la page: Technische Eigenschaften und Verpackungen auf Seite: **438**

## PEZZI SPECIALI TRIMS ACCESSOIRES FORMSTÜCKE

**Battiscopa Bullnose**  
**Plinthe à bord arrondi**  
**Stehsockel**  
**cm 9x30** - 3<sup>1</sup>/<sub>2</sub>"x11<sup>3</sup>/<sub>4</sub>"  
**cm 9x60** - 3<sup>1</sup>/<sub>2</sub>"x23<sup>5</sup>/<sub>8</sub>"



**Gradino Step tread**  
**Nez de marche Stufenplatte**  
**cm 30x30** - 11<sup>3</sup>/<sub>4</sub>"x11<sup>3</sup>/<sub>4</sub>"  
**cm 30x60** - 11<sup>3</sup>/<sub>4</sub>"x23<sup>5</sup>/<sub>8</sub>"

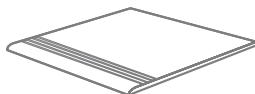

**patio grey**

# patio

GRESPLUS



patio grey cm 20x20 - 77/8"x77/8", cm 20x40 - 77/8"x153/4"

## COLORI COLOURS COULEURS FARBEN

patio grey



patio white



patio gold



patio beige

Caratteristiche tecniche ed estetiche a pagina: Technical and aesthetics features on page:  
Caractéristiques techniques et esthétiques à la page : Technische und ästhetische Eigenschaften auf Seite: **444**

## FORMATI SIZES FORMATS FORMATE

# patio

GRESPLUS

Formati Sizes  
Formats Formate



cm 20x20  
7<sup>7</sup>/<sub>8</sub>"x7<sup>7</sup>/<sub>8</sub>"



cm 20x40  
7<sup>7</sup>/<sub>8</sub>"x 15<sup>3</sup>/<sub>4</sub>"

Superfici Surfaces  
Surfaces Oberflächen



mm 8

mm 8



Accentuata  
Accentuated  
Importante  
Starke

Vedi pagina: See page: Voir page : Siehe Seite: **448**

● Naturale Matt Naturelle Matt **R11 A+B**

Caratteristiche tecniche e imballi a pagina: Technical features and packing on page: Caractéristiques techniques et emballages à la page: Technische Eigenschaften und Verpackungen auf Seite: **444**

## PEZZI SPECIALI TRIMS ACCESSOIRES FORMSTÜCKE

**Battiscopa**  
**Bullnose**  
**Plinthe à bord arrondi**  
**Stehsockel**  
cm 8x40 - 3<sup>1</sup>/<sub>8</sub>"x15<sup>3</sup>/<sub>4</sub>"



**Terminale** Pezzo unico pressato  
Pièce unique pressée  
Pressed single piece  
Gepresstes Einzelstück  
cm 15x30x3,5 - 5<sup>7</sup>/<sub>8</sub>"x11<sup>3</sup>/<sub>4</sub>"x1<sup>3</sup>/<sub>8</sub>"

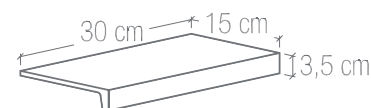

patio gold cm 20x40 - 7<sup>7</sup>/<sub>8</sub>"x15<sup>3</sup>/<sub>4</sub>"

**agorà** megalopoli





**sparta, corinto** cm 15x15 - 5<sup>7</sup>/<sub>8</sub>"x5<sup>7</sup>/<sub>8</sub>", 15x30 - 5<sup>7</sup>/<sub>8</sub>"x11<sup>3</sup>/<sub>4</sub>", 30x30 - 11<sup>3</sup>/<sub>4</sub>"x11<sup>3</sup>/<sub>4</sub>"

## COLORI COLOURS COULEURS FARBEN

elatea



megalopoli



corinto











sparta

Caratteristiche tecniche ed estetiche a pagina: Technical and aesthetics features on page:  
Caractéristiques techniques et esthétiques à la page : Technische und ästhetische Eigenschaften auf Seite: **434**

# FORMATI SIZES FORMATS FORMATE



Formati Sizes Formats Formate	 <b>cm 15x15</b> 57/8"x57/8"	 <b>cm 15x30</b> 57/8"x113/4"	 <b>cm 30x30</b> 113/4"x113/4"
Superfici Surfaces Surfaces Oberflächen			
	mm 8	mm 8	mm 8
 Accentuata Accentuated Importante Starke	 Naturale Matt Naturelle Matt <b>R11 A+B</b>		

Vedi pagina: See page: Voir page : Siehe Seite: **448**

Caratteristiche tecniche e imballi a pagina: Technical features and packing on page: Caractéristiques techniques et emballages à la page: Technische Eigenschaften und Verpackungen auf Seite: **434**

# PEZZI SPECIALI TRIMS ACCESSOIRES FORMSTÜCKE

**Battiscopa Bullnose**  
**Plinthe à bord arrondi**  
**Stehsockel**  
cm 9x30 - 3 1/2"x11 3/4"



**Gradino Step tread**  
**Nez de marche**  
**Stufenplatte**  
cm 30x30 - 11 3/4"x11 3/4"

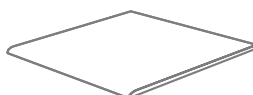

**Terminale** Pezzo unico  
Pièce unique Single piece  
Einzelstück  
cm 15x30x3,5 - 57/8"x11 3/4"x1 3/8"

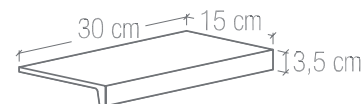

sparta, corinto cm 15x15 - 57/8"x57/8", 15x30 - 57/8"x11 3/4", 30x30 - 11 3/4"x11 3/4"

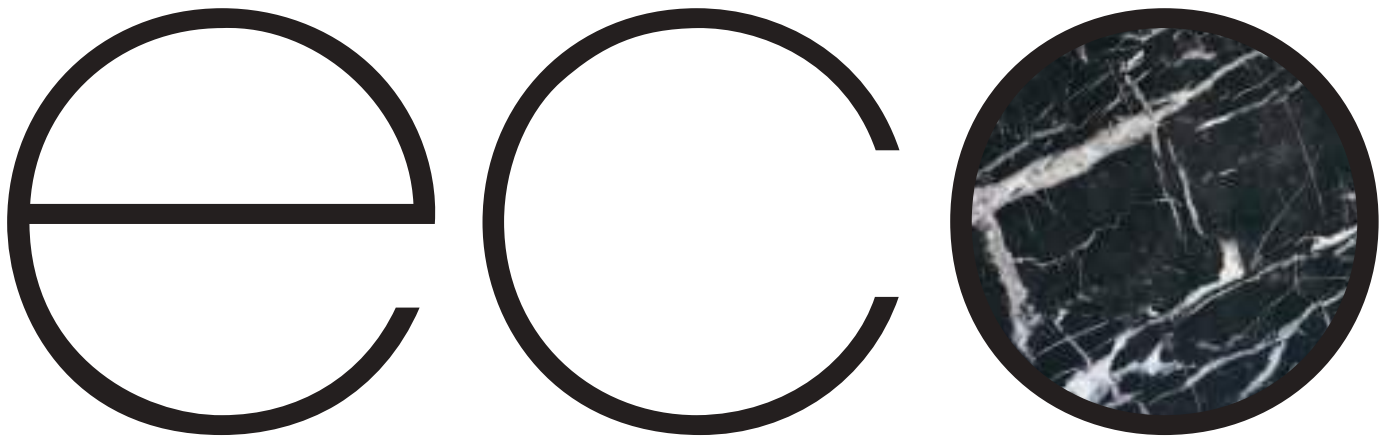

eco**marble** écomar**bre** ökomar**mor**

**marmo**

# ecomarmo

150	marmoker
172	marmosmart
178	terrazzo
184	macro
188	marte
200	onici

## MARMO

Roccia cristallina, da decorazione e costruzione, lucidabile e di natura compatta prevalentemente costituita da minerale di durezza Mohs da 3 a 4, quali calciti, dolomiti e serpentini. In funzione della sua composizione mineralogica la roccia cristallina può essere sintetizzata in quattro grandi categorie: alla prima appartengono i marmi propriamente detti [ovvero calcari metamorfici ricristallizzati], i calcefiri e i cipollini.

Alla seconda i calcari, le dolomie e le breccie calcaree lucidabili. Alla terza i serpentini. Alla quarta le oficalciti.

## MARBLE

Crystalline rock for building and decorative purposes that can be polished. Characterized by a compact nature, it mainly consists of minerals with 3 to 4 Mohs hardness, such as calcites, dolomites and serpentine rocks. Depending on its mineralogical composition, crystalline rock can be roughly divided into four large categories: marbles in the strict sense belong to the first category [i.e. recrystallized metamorphic limestones], along with calciferous and carystium rocks. The second category includes limestones, dolomites and limestone breccia fit for polishing. Serpentine rocks belong to the third category and ophicalcites to the fourth.





**marmoker** night storm



# marmoker

GRANITOKER



**night storm** cm 120x278 - 47<sup>1</sup>/<sub>4</sub>"x109<sup>1</sup>/<sub>2</sub>", **titan white** cm 120x120 - 47<sup>1</sup>/<sub>4</sub>"x47<sup>1</sup>/<sub>4</sub>"

## COLORI COLOURS COULEURS FARBEN

nero creta



night storm



grafite



ossidiana

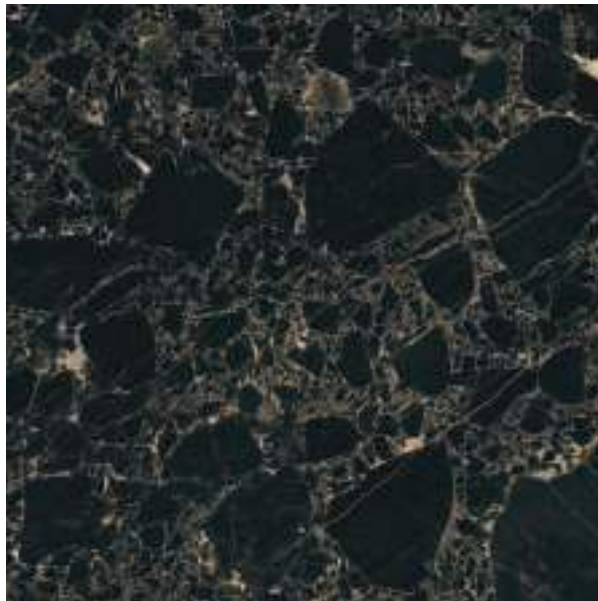

orange black



saint laurent

# marmoker

GRANITOKER

breccia carsica



bardiglio imperiale



oyster grey

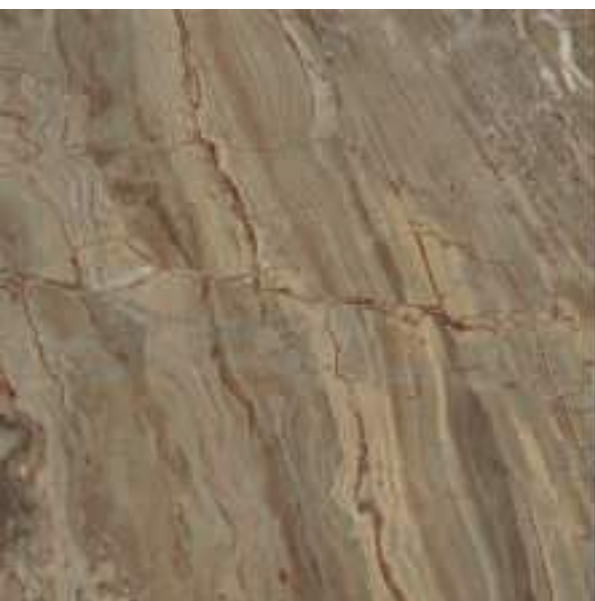

birimbau



brown forest

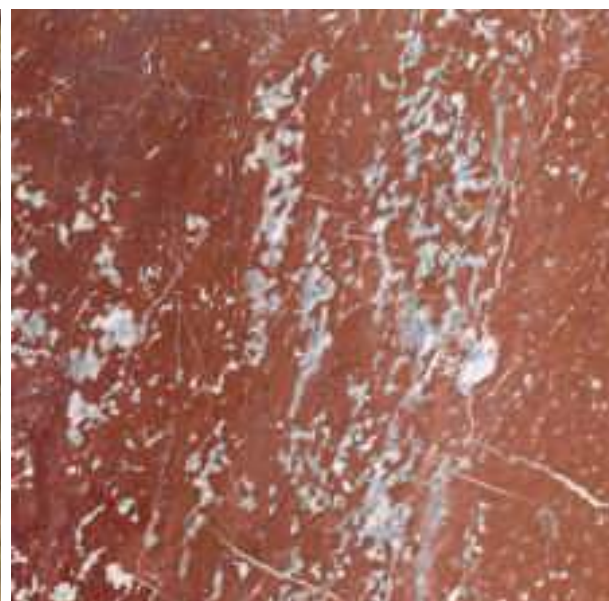

rosso francia

## COLORI COLOURS COULEURS FARBEN

verde aver



caribbean green



fior di pesco



travertino titanium



jolie



pulpis tortora

# marmoker

GRANITOKER

travertino miele



rosato



arabesque



travertino romano

crema select

zebrino

## COLORI COLOURS COULEURS FARBEN

olimpo



travertino bianco



titan white

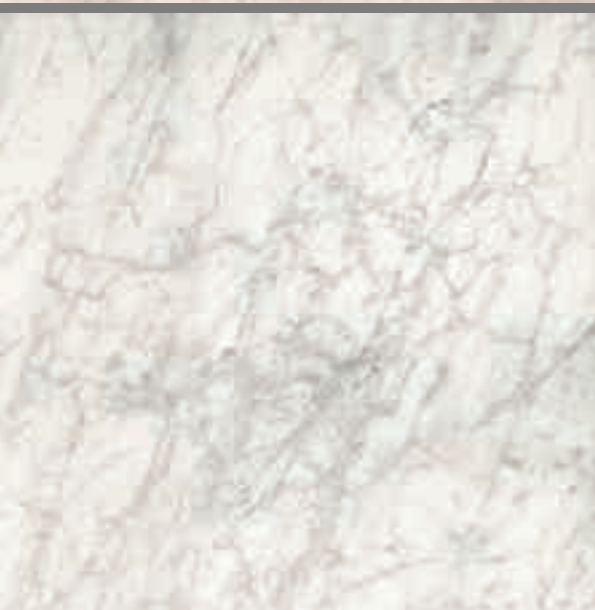

bardiglio bianco



bianco vietnam



canova

# marmoker

GRANITOKER

statuario grigio







statuario oro



calacatta extra

## FORMATI SIZES FORMATS FORMATE

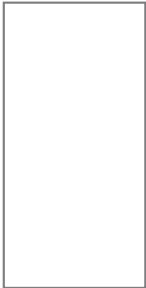
						
Formati Sizes	<b>cm 30x60</b>	<b>cm 60x60</b>	<b>cm 60x120</b>	<b>cm 45x90</b>	<b>cm 90x90</b>	<b>cm 90x180</b>
Formats Formate	11 <sup>3</sup> / <sub>4</sub> "x23 <sup>5</sup> / <sub>8</sub> "	23 <sup>5</sup> / <sub>8</sub> "x23 <sup>5</sup> / <sub>8</sub> "	23 <sup>5</sup> / <sub>8</sub> "x47 <sup>1</sup> / <sub>4</sub> "	17 <sup>3</sup> / <sub>4</sub> "x35 <sup>3</sup> / <sub>8</sub> "	35 <sup>3</sup> / <sub>8</sub> "x35 <sup>3</sup> / <sub>8</sub> "	35 <sup>3</sup> / <sub>8</sub> "x70 <sup>7</sup> / <sub>8</sub> "
	mm 10	mm 10	mm 10	mm 10	mm 10	mm 10
Arabesque				● ●	● ●	● ●
Bardiglio Bianco	● ●	● ●	● ●			
Bardiglio Imperiale	● ●	● ●	● ●			
Bianco Vietnam				● ●	● ●	● ●
Birimbau	● ●	● ●	● ●			
Breccia Carsica	● ●	● ●	● ●	● ●	● ●	● ●
Brown Forest	● ●	● ●	● ●			
Calacatta Extra	● ● ●	● ● ●	● ● ●	● ●	● ●	● ●
Canova	● ●	● ●	● ●			
Caribbean Green	● ●	● ●	● ●			
Crema Select	● ●	● ●	● ●			
Fior di pesco	● ●	● ●	● ●			
Grafite	● ● ●	● ● ●	● ● ●	● ●	● ●	● ●
Jolie	● ●	● ●	● ●	● ●	● ●	● ●
Nero Creta	● ● ●	● ● ●	● ● ●	● ●	● ●	● ●
Night Storm	● ●	● ●	● ●	● ●	● ●	● ●
Olimpo	● ●	● ●	● ●			
Orange Black	● ●	● ●	● ●			
Ossidiana	● ●	● ●	● ●			
Oyster Grey	● ●	● ●	● ●			
Pulpis Tortora	● ●	● ●	● ●			
Rosato	● ●	● ●	● ●			
Rosso Francia	● ●	● ●	● ●			
Saint Laurent	● ●	● ●	● ●			
Statuario Grigio	● ● ●	● ● ●	● ● ●	● ●	● ●	● ●
Statuario Oro	● ● ●	● ● ●	● ● ●	● ●	● ●	● ●
Titan White	● ●	● ●	● ●	● ●	● ●	● ●
Travertino Bianco	● ●	● ●	● ●			
Travertino Miele	● ●	● ●	● ●			
Travertino Romano	● ●	● ●	● ●			
Travertino Titanium	● ●	● ●	● ●	● ●	● ●	● ●
Verde Aver	● ●	● ●	● ●	● ●	● ●	● ●
Zebrino	● ●	● ●	● ●			

Rettificata in un unico calibro Rectified version in a single caliber Rectifiés en un unique calibre Boden Sie in einem einzigen Kaliber

Caratteristiche tecniche e imballi a pagina: Technical features and packing on page:

Caractéristiques techniques et emballages à la page: Technische Eigenschaften und Verpackungen auf Seite: 440

- Naturale Matt Naturelle Matt **R9**
- **R10 A+B PTV>36**
- Honed
- Lucida



K Grandi Lastre K<sub>ontinua</sub>  
 K<sub>ontinua</sub> Big Slabs  
 Grandes Dalles K<sub>ontinua</sub>  
 K<sub>ontinua</sub> große Platten

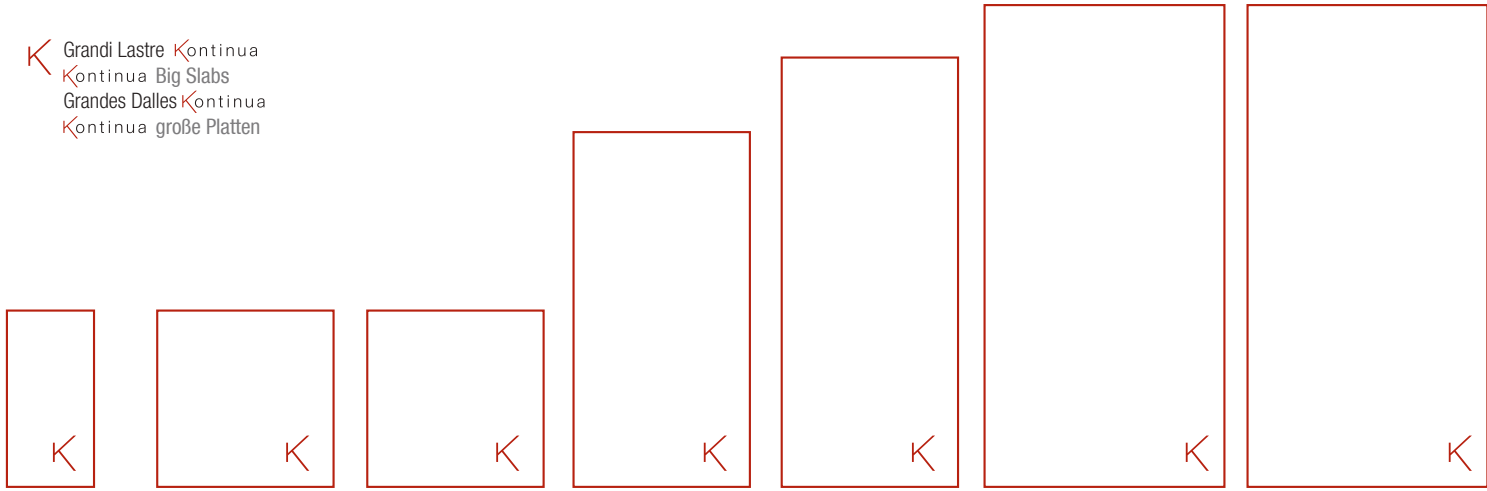

<b>cm 60x120</b> 23 <sup>5</sup> / <sub>8</sub> "x47 <sup>1</sup> / <sub>4</sub> "	<b>cm 120x120</b> 47 <sup>1</sup> / <sub>4</sub> "x47 <sup>1</sup> / <sub>4</sub> "	<b>cm 120x120</b> 47 <sup>1</sup> / <sub>4</sub> "x47 <sup>1</sup> / <sub>4</sub> "	<b>cm 120x240</b> 47 <sup>1</sup> / <sub>4</sub> "x94 <sup>1</sup> / <sub>2</sub> "	<b>cm 120x278</b> 47 <sup>1</sup> / <sub>4</sub> "x109 <sup>1</sup> / <sub>2</sub> "	<b>cm 160x320</b> 63"x126"	<b>cm 160x320**</b> 63"x126"
mm 6,5	mm 10	mm 6,5	mm 6,5	mm 6,5	mm 6,5	mm 12

● ●	● ●	● ● +BM					Arabesque
● ●	● ●	● ●	● ●				Bardiglio Bianco
● ●	● ●	● ●	● ●				Bardiglio Imperiale
● ●	● ●	● ●	● ●				Bianco Vietnam
							Birimbau
							Breccia Carsica
● ●	● ●	● ●					Brown Forest
● ●	● ●	● ●	● ● +BM	● ●	● ● +BM	● ● +BM	Calacatta Extra
● ●	● ●	● ●	● ●	● ●	● ●	● ●	Canova
● ●	● ●	● ●	● ●				Caribbean Green
							Crema Select
● ●	● ●	● ● +BM					Fior di pesco
● ●	● ●	● ●	● ●	● ●	● ●	● ●	Grafite
							Jolie
● ●	● ●	● ●	● ●				Nero Creta
● ●	● ●	● ●	● ●	● ●	● ● +BM	● ● +BM	Night Storm
● ●	● ●	● ●	● ●				Olimpo
● ●	● ●	● ●	● ●				Orange Black
● ●	● ●	● ●	● ●	● ●	● ●	● ●	Ossidiana
● ●	● ●	● ●	● ●	● ●			Oyster Grey
● ●	● ●	● ●					Pulpis Tortora
							Rosato
● ●	● ●	● ●	● ●				Rosso Francia
● ●	● ●	● ●	● ●				Saint Laurent
● ●	● ●	● ●	● ● +BM +EM	● ● +BM +EM	● ●	● ● +BM	Statuario Grigio
● ●	● ●	● ●	● ● +BM +EM	● ● +BM +EM	● ●	● ● +BM	Statuario Oro
● ●							Titan White
							Travertino Bianco
							Travertino Miele
							Travertino Romano
● ●	● ●	● ●					Travertino Titanium
							Verde Aver
							Zebrino

\*\* Non rettificato Not rectified Non rectifié Nicht rektifizierte

- Honed
- Naturale Matt Naturelle Matt
- Lucida
- BM bookmatch
- EM endmatch

## PEZZI SPECIALI TRIMS ACCESSOIRES FORMSTÜCKE

**Battiscopa Bullnose**  
 Plinthe à bord arrondi  
 Stehsockel  
 cm 7x60 - 2<sup>3</sup>/<sub>4</sub>"x23<sup>5</sup>/<sub>8</sub>"  
 cm 7x90 - 2<sup>3</sup>/<sub>4</sub>"x35<sup>3</sup>/<sub>8</sub>"



**Gradino Step tread**  
 Nez de marche Stufenplatte  
 cm 30x60 - 11<sup>3</sup>/<sub>4</sub>"x23<sup>5</sup>/<sub>8</sub>"  
 cm 30x90 - 11<sup>3</sup>/<sub>4</sub>"x35<sup>3</sup>/<sub>8</sub>"

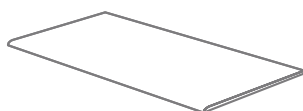

**Gradone (assemblato)**  
 cm 120x33 - 47<sup>1</sup>/<sub>4</sub>"x13"  
 cm 180x33 - 70<sup>7</sup>/<sub>8</sub>"x13"

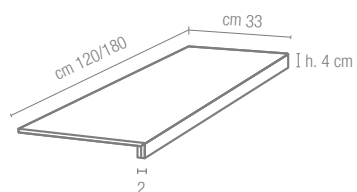

**Angolare (assemblato)**  
 cm 120x33 - 47<sup>1</sup>/<sub>4</sub>"x13"  
 cm 180x33 - 70<sup>7</sup>/<sub>8</sub>"x13"

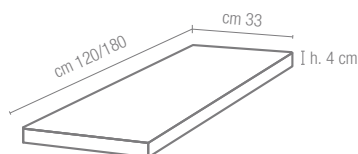

statuario grigio *lucida* cm 90x180 - 35<sup>3</sup>/<sub>8</sub>"x70<sup>7</sup>/<sub>8</sub>", grafite *matt* cm 90x90 - 35<sup>3</sup>/<sub>8</sub>"x35<sup>3</sup>/<sub>8</sub>"

SUPERFICI SURFACES  
SURFACES OBERFLÄCHEN

**marmoker**

GRANITOKER

lucida

**naturale** matt  
naturelle **matt**

honed

# Kontinua BOOKMATCH

cm 120x240 - 120x278 - 160x320

## statuario grigio

Rettificate in un unico calibro  
 Single caliber, rectified version  
 Rectifiés en un unique calibre  
 Einem einzigen Werkmass  
 maßgeschliffen geliefert

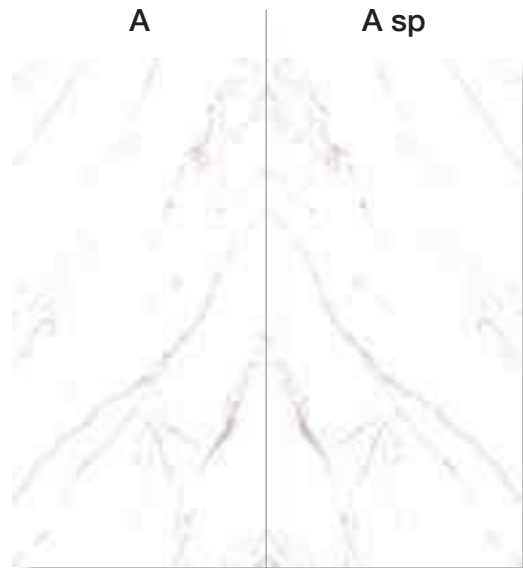

A sp	A
A	A sp



A	A sp
A sp	A

**K**ontinua BOOKMATCH  
 cm 120x240 - 120x278 - 160x320  
 statuario oro

**marmoker**

GRANITOKER

Rettificate in un unico calibro  
 Single caliber, rectified version  
 Rectifiés en un unique calibre  
 Einem einzigen Werkmass  
 maßgeschliffen geliefert



A sp	A
A	A sp



A	A sp
A sp	A

# Kontinua BOOKMATCH

**cm 120x240**  
fior di pesco

Rettificate in un unico calibro  
Single caliber, rectified version  
Rectifiés en un unique calibre  
Einem einzigen Werkmass  
maßgeschliffen geliefert



A sp	A
A	A sp



A	A sp
A sp	A

**K**ontinua BOOKMATCH  
**cm 120x240**  
 arabesque

Rettificate in un unico calibro  
 Single caliber, rectified version  
 Rectifiés en un unique calibre  
 Einem einzigen Werkmass  
 maßgeschliffen geliefert

**marmoker**

GRANITOKER



A sp	A
A	A sp

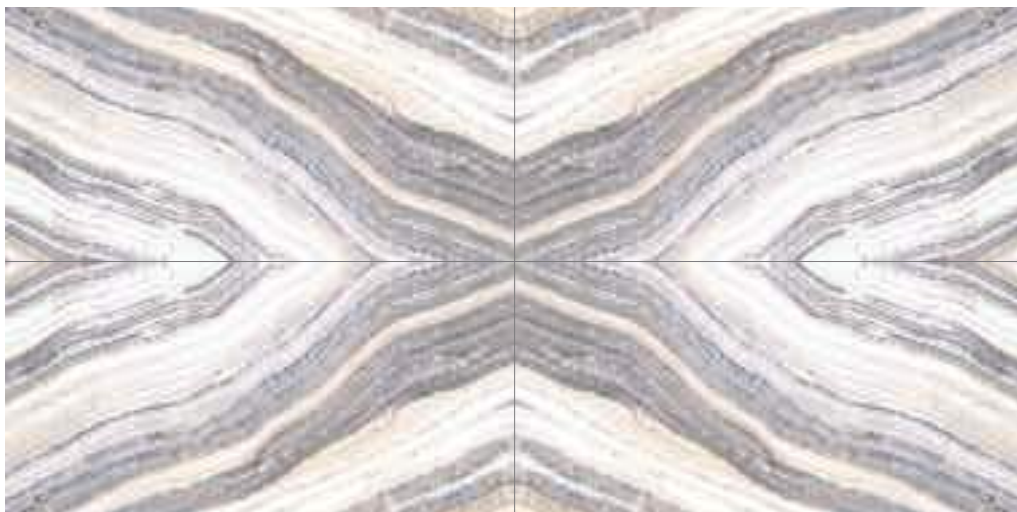

A	A sp
A sp	A

# Kontinua BOOKMATCH

cm 120x278 - 160x320

## calacatta extra

Rettificate in un unico calibro  
 Single caliber, rectified version  
 Rectifiés en un unique calibre  
 Einem einzigen Werkmass  
 maßgeschliffen geliefert

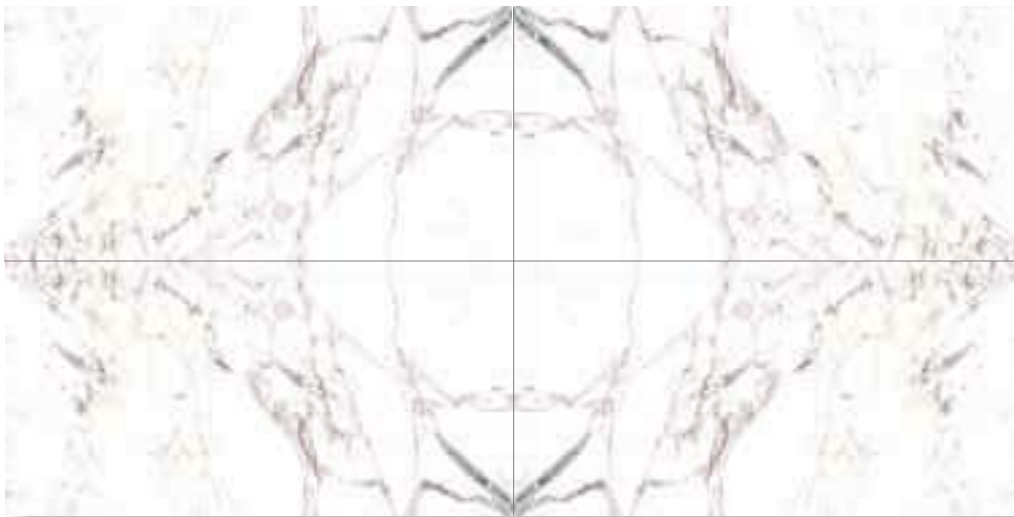
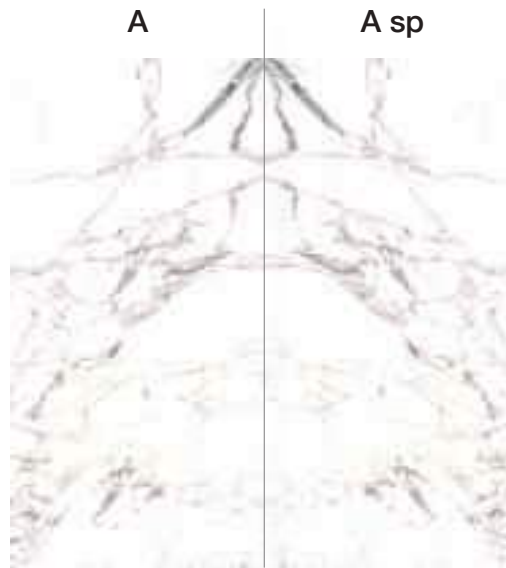

A sp	A
A	A sp

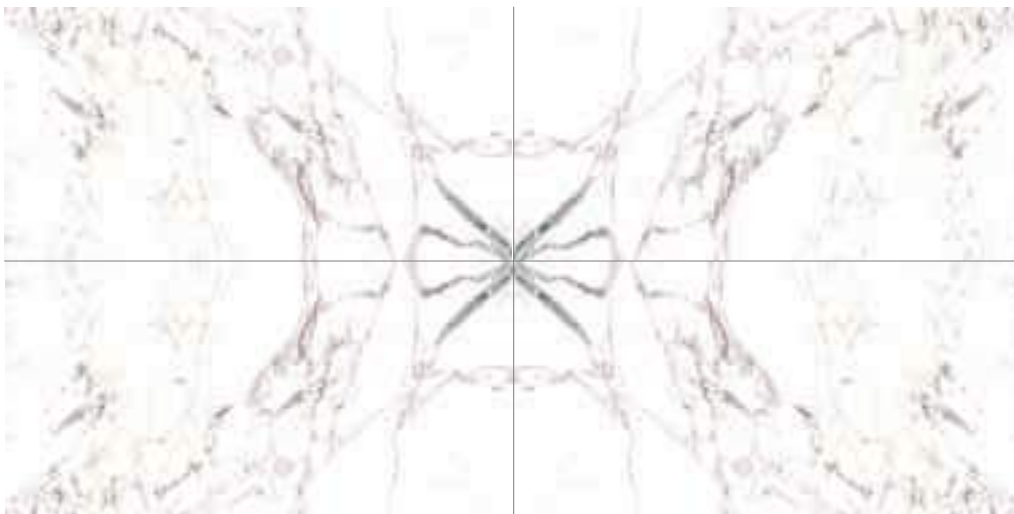

A	A sp
A sp	A



**K**ontinua ENDMATCH  
 cm 120x240 - 120x278

**marmoker**

GRANITOKER

**statuario grigio**

Rettificate in un unico calibro  
 Single caliber, rectified version  
 Rectifiés en un unique calibre  
 Einem einzigen Werkmass  
 maßgeschliffen geliefert

statuario grigio **A**

statuario grigio **B**

statuario grigio **C**

statuario grigio **D**



**statuario oro**

Rettificate in un unico calibro  
 Single caliber, rectified version  
 Rectifiés en un unique calibre  
 Einem einzigen Werkmass  
 maßgeschliffen geliefert

statuario oro **A**

statuario oro **B**

statuario oro **C**

statuario oro **D**



## DECORI DECORS DÉCORS DEKORE

mosaico\*



**cm 30x30** - 11<sup>3</sup>/<sub>4</sub>"x11<sup>3</sup>/<sub>4</sub>"  
 tessera **cm 2,3x2,3** - 1"x1"  
 su rete on net sur trame auf Netz

▼  
▲ mm 10

Kontinua ▼  
▲ mm 6,5

Superficie naturale e lucida Matt and lucida surface  
 Surface naturelle et lucida Matte und lucida Oberfläche

mosaico 5x10\*



**cm 30x30** - 11<sup>3</sup>/<sub>4</sub>"x11<sup>3</sup>/<sub>4</sub>"  
 tessera **cm 5x10** - 2"x4"  
 su rete on net sur trame auf Netz

▼  
▲ mm 10

Kontinua ▼  
▲ mm 6,5

Superficie naturale e lucida Matt and lucida surface  
 Surface naturelle et lucida Matte und lucida Oberfläche

mosaico decoro\*



**cm 30x30** - 11<sup>3</sup>/<sub>4</sub>"x11<sup>3</sup>/<sub>4</sub>"  
 tessera **cm 2,3x2,3** - 1"x1"  
 su rete on net sur trame auf Netz

▼  
▲ mm 10

Solo superficie lucida Lucida surface only  
 Seulement surface lucida Nur in lucida Oberfläche

\* Disponibile in tutti i colori della serie Available in all the colours of the series Disponible dans tous les couleurs e la série Verfügbar in allen Farben



**mosaico decoro nero creta lucida**  
 cm 30x30 - 11<sup>5</sup>/<sub>8</sub>"x11<sup>5</sup>/<sub>8</sub>"  
**nero creta, statuario grigio lucida**  
 cm 60x120 - 23<sup>1</sup>/<sub>4</sub>"x46<sup>1</sup>/<sub>2</sub>"

# marmoker

rosone marmoker

granitoker

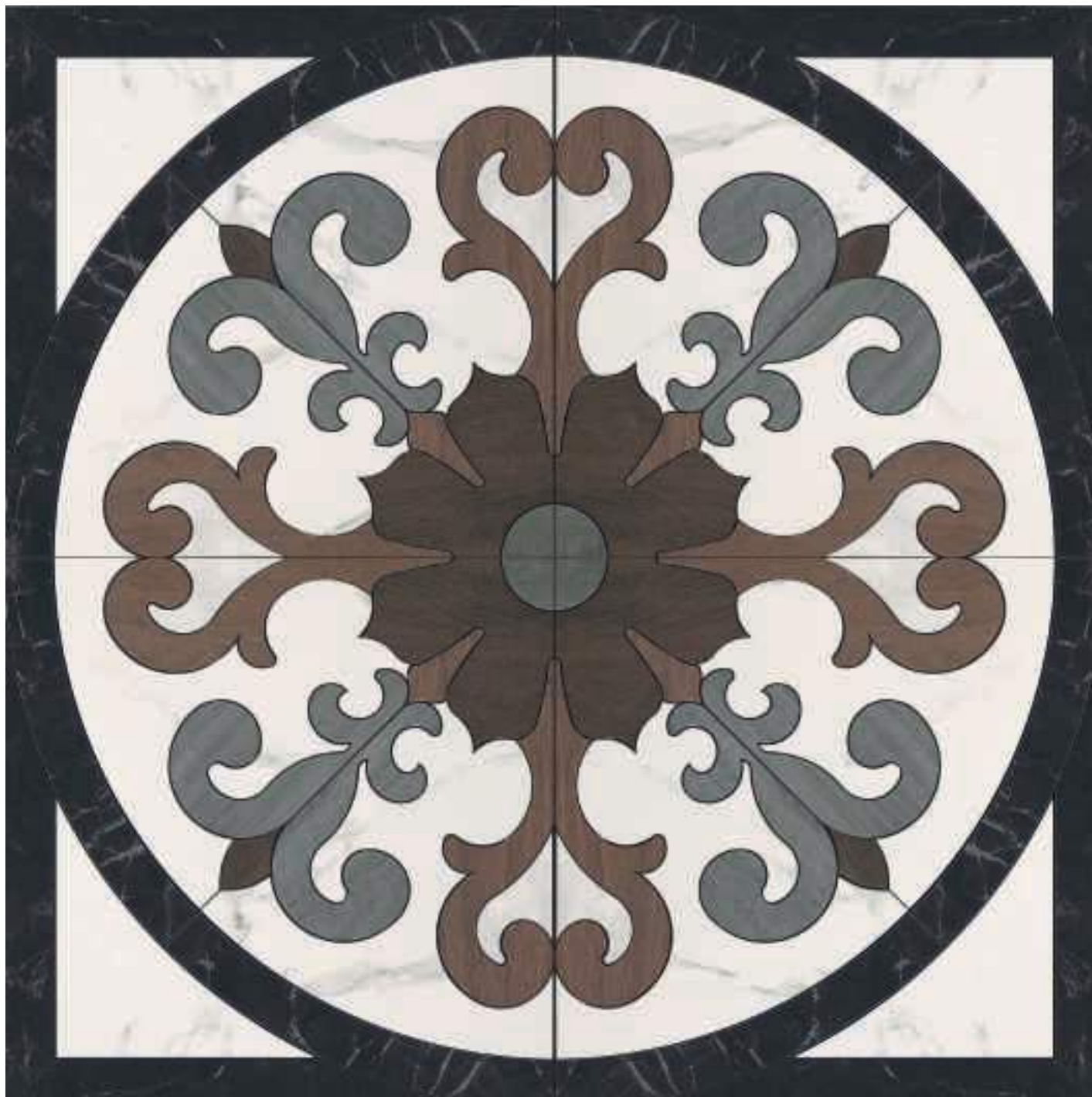

cm 120x120 - 47<sup>1</sup>/<sub>4</sub>"x47<sup>1</sup>/<sub>4</sub>"

statuario grigio, nero creta, tavolato antracite, tavolato marrone medio, tavolato marrone scuro

Solo superficie lucida. Lucida surface only. Seulement surface lucida. Nur in lucida Oberfläche.

## DECORI DECORS DÉCORS DEKORE

esagono\*



cm 30x51,9 - 11<sup>3</sup>/<sub>4</sub>"x 20<sup>3</sup>/<sub>8</sub>"

Solo superficie lucida Lucida surface only  
Seulement surface lucida Nur in lucida Oberfläche

esagoni\*

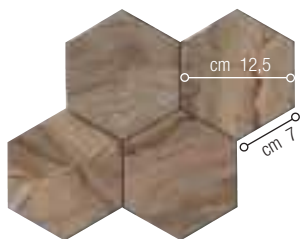

cm 21,5x25 - 8<sup>1</sup>/<sub>2</sub>"x 9<sup>7</sup>/<sub>8</sub>"  
su rete on net sur trame auf Netz

Solo superficie lucida  
Lucida surface only  
Seulement surface lucida  
Nur in lucida Oberfläche

esagoni 3D\*\*

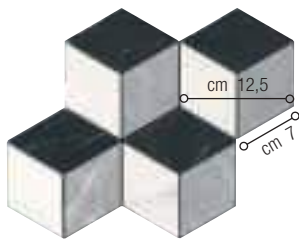

cm 21,5x25 - 8<sup>1</sup>/<sub>2</sub>"x 9<sup>7</sup>/<sub>8</sub>"  
su rete on net sur trame auf Netz

Solo superficie lucida  
Lucida surface only  
Seulement surface lucida  
Nur in lucida Oberfläche

\* Disponibile nei colori: Available in the colours:  
Disponibile dans les couleurs: Verfügbar in den folgenden Farben:  
**Bardiglio Bianco, Birimbau, Bardiglio Imperiale, Canova, Crema Select,  
Nero Creta, Olimpo, Pulpis Tortora, Rosato, Saint Laurent, Statuario Grigio,  
Statuario Oro, Zebrino**

\*\* **Bardiglio Imperiale, Nero Creta, Statuario Grigio**



# marmoker

golden paint

GRANITOKER

Decoro abbinabile con  
le collezioni Pietre di Paragone,  
Pietre di Sardegna e Marmoker  
Decor matching the Pietre di  
Paragone, Pietre di Sardegna  
and Marmoker collections  
Décor pouvant être associé aux  
collections Pietre di Paragone,  
Pietre di Sardegna et Marmoker  
Dekor kombinierbar mit den  
Kollektionen Pietre di Paragone,  
Pietre di Sardegna und Marmoker



cm 120x240 47<sup>1</sup>/<sub>4</sub>"x 94<sup>1</sup>/<sub>2</sub>"

▼  
▲ Kontinua mm 6,5



**marmosmart** pietrasanta smart

# marmosmart

GRANITOKER



**marquina smart** cm 90x270 - 35<sup>3</sup>/<sub>8</sub>"x106<sup>1</sup>/<sub>4</sub>", **pietrasanta smart** cm 90x270 - 35<sup>3</sup>/<sub>8</sub>"x106<sup>1</sup>/<sub>4</sub>", 90x90 - 35<sup>3</sup>/<sub>8</sub>"x35<sup>3</sup>/<sub>8</sub>"

## COLORI COLOURS COULEURS FARBEN

marquina smart



tortora smart



fossena smart



adria smart



tivoli smart



vaghi smart



# marmosmart

GRANITOKER

lasa smart









pietrasanta smart

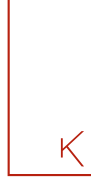
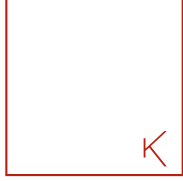

statuarietto smart

## FORMATI SIZES FORMATS FORMATE

							
<b>Formati Sizes</b> <b>Formats Formate</b>	<b>cm 30x60</b> 11 <sup>3</sup> / <sub>4</sub> "x23 <sup>5</sup> / <sub>8</sub> "	<b>cm 60x60</b> 23 <sup>5</sup> / <sub>8</sub> "x23 <sup>5</sup> / <sub>8</sub> "	<b>cm 60x120</b> 23 <sup>5</sup> / <sub>8</sub> "x47 <sup>1</sup> / <sub>4</sub> "	<b>cm 30x90</b> 11 <sup>5</sup> / <sub>8</sub> "x35 <sup>3</sup> / <sub>8</sub> "	<b>cm 45x90</b> 17 <sup>3</sup> / <sub>4</sub> "x35 <sup>3</sup> / <sub>8</sub> "	<b>cm 90x90</b> 35 <sup>3</sup> / <sub>8</sub> "x35 <sup>3</sup> / <sub>8</sub> "	<b>cm 90x270</b> 35 <sup>3</sup> / <sub>8</sub> "x106 <sup>1</sup> / <sub>4</sub> "
<b>Superfici Surfaces</b> <b>Surfaces Oberflächen</b>	● ● ●	● ● ●	● ● ●	● ●	● ●	● ●	● ●
	mm 9	mm 9	mm 9	mm 6	mm 6	mm 6	mm 6

**K** Grandi Lastre **K**ontinua  
**K**ontinua Big Slabs  
 Grandes Dalles **K**ontinua  
**K**ontinua große Platten

● Honed  
 ● **R10 A+B PTV > 36**  
 ● Lucida

Rettificate in un unico calibro Rectified version in a single caliber Rectifiés en un unique calibre Boden Sie in einem einzigen Kaliber

Caratteristiche tecniche e imballi a pagina: Technical features and packing on page: Caractéristiques techniques et emballages à la page: Technische Eigenschaften und Verpackungen auf Seite: **440**

## PEZZI SPECIALI TRIMS ACCESSOIRES FORMSTÜCKE

**Battiscopa Bullnose**  
**Plinthe à bord arrondi**  
**Stehsokkel**  
 cm 7x60- 2<sup>3</sup>/<sub>4</sub>"x23<sup>5</sup>/<sub>8</sub>"



**Gradino Step tread**  
**Nez de marche Stufenplatte**  
 cm 30x60 - 11<sup>3</sup>/<sub>4</sub>"x23<sup>5</sup>/<sub>8</sub>"

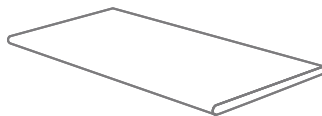

**Gradone (assemblato)**  
 cm 120x33 - 47<sup>1</sup>/<sub>4</sub>"x13"

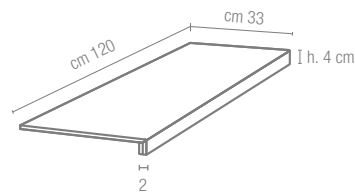

**Angolare (assemblato)**  
 cm 120x33 - 47<sup>1</sup>/<sub>4</sub>"x13"

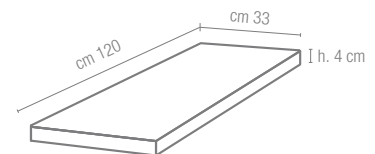

DECORI DECORS DÉCORS DEKORE

**marmosmart**

GRANITOKER

mosaico\*

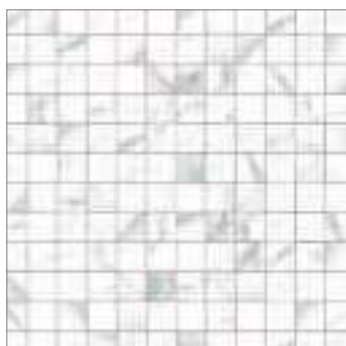

**cm 30x30** - 11<sup>3</sup>/<sub>4</sub>"x11<sup>3</sup>/<sub>4</sub>"  
 tessera **cm 2,3x2,3** - 1"x1"  
 su rete on net sur trame auf Netz

mm 9

mosaico 5x10\*



**cm 30x30** - 11<sup>3</sup>/<sub>4</sub>"x11<sup>3</sup>/<sub>4</sub>"  
 tessera **cm 5x10** - 2"x4"  
 su rete on net sur trame auf Netz

mm 9

\* Disponibile in tutti i colori della serie Available in all the colours of the series Disponible dans tous les couleurs e la série Verfügbar in allen farben



statuarietto smart cm 90x90 - 35<sup>3</sup>/<sub>8</sub>"x35<sup>3</sup>/<sub>8</sub>", fossena smart cm 90x270 - 35<sup>3</sup>/<sub>8</sub>"x106<sup>1</sup>/<sub>4</sub>"

terrazzo grey

# terrazzo

GRESPLUS



terrazzo grey cm 75,5x75,5 - 29<sup>3</sup>/<sub>4</sub>"x29<sup>3</sup>/<sub>4</sub>", cm 37,5x75,5 - 14<sup>3</sup>/<sub>4</sub>"x29<sup>3</sup>/<sub>4</sub>

## COLORI COLOURS COULEURS FARBEN

terrazzo black



terrazzo grey

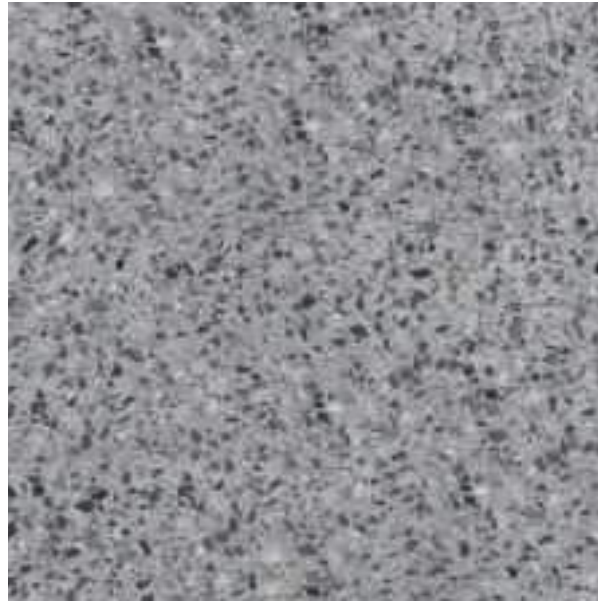

terrazzo pearl

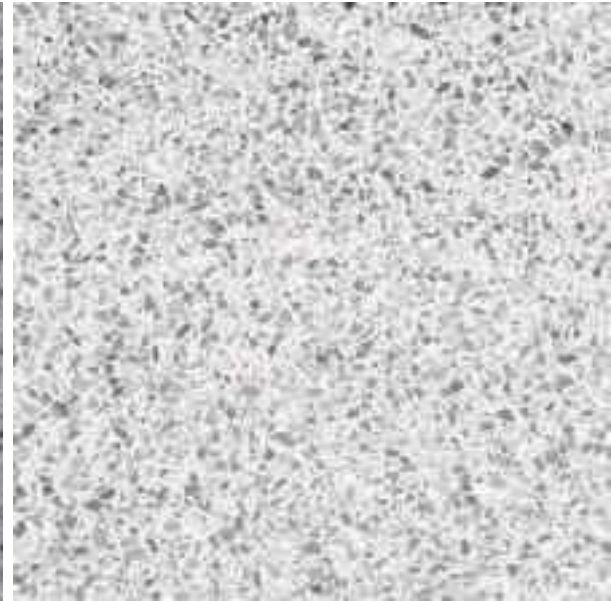

terrazzo beige



terrazzo white

SUPERFICI SURFACES SURFACES OBERFLÄCHEN





**terrazzo**

GRESPLUS

naturale matt  
naturelle matt  
R10

lappata

## FORMATI SIZES FORMATS FORMATE

Formati Sizes Formats Formate	 <b>cm 30x60</b> 11 <sup>3</sup> / <sub>4</sub> "x23 <sup>5</sup> / <sub>8</sub> "	 <b>cm 60x60</b> 23 <sup>5</sup> / <sub>8</sub> "x23 <sup>5</sup> / <sub>8</sub> "	 <b>cm 37,5x75,5</b> 14 <sup>3</sup> / <sub>4</sub> "x29 <sup>3</sup> / <sub>4</sub> "	 <b>cm 75,5x75,5</b> 29 <sup>3</sup> / <sub>4</sub> "x29 <sup>3</sup> / <sub>4</sub> "
Superfici Surfaces Surfaces Oberflächen	● ●	● ●	● ●	● ●
	mm 9	mm 9	mm 10	mm 10

- Naturale Matt Naturelle Matt **R10**
- Lappata

Rettificate in un unico calibro Rectified version in a single caliber Rectifiés en un unique calibre Boden Sie in einem einzigen Kaliber

Caratteristiche tecniche e imballi a pagina: Technical features and packing on page: Caractéristiques techniques et emballages à la page: Technische Eigenschaften und Verpackungen auf Seite: **444**

## PEZZI SPECIALI TRIMS ACCESSOIRES FORMSTÜCKE

**Battiscopa Bullnose**  
**Plinthe à bord arrondi**  
**Stehsockel**  
cm 7x75,5 - 2<sup>3</sup>/<sub>4</sub>"x29<sup>3</sup>/<sub>4</sub>"  
cm 7x60 - 2<sup>3</sup>/<sub>4</sub>"x23<sup>5</sup>/<sub>8</sub>"



**Gradino Step tread**  
**Nez de marche Stufenplatte**  
cm 37,5x75,5 - 14<sup>3</sup>/<sub>4</sub>"x29<sup>3</sup>/<sub>4</sub>"  
cm 30x60 - 11<sup>5</sup>/<sub>8</sub>"x23<sup>5</sup>/<sub>8</sub>"

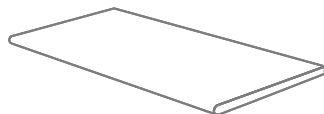

**Gradone (assemblato)**  
cm 75,5x33 - 29<sup>3</sup>/<sub>4</sub>"x13"  
cm 60x33 - 23<sup>5</sup>/<sub>8</sub>"x13"

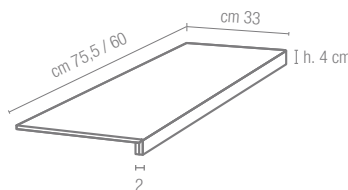

**Angolare (assemblato)**  
cm 75,5x33 - 29<sup>3</sup>/<sub>4</sub>"x13"  
cm 60x33 - 23<sup>5</sup>/<sub>8</sub>"x13"

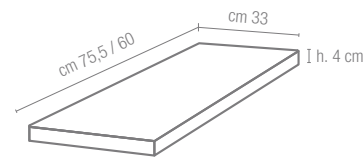

terrazzo white cm 37,5x75,5 - 14<sup>3</sup>/<sub>4</sub>"x29<sup>3</sup>/<sub>4</sub>"  
terrazzo pearl cm 75,5x75,5 - 29<sup>3</sup>/<sub>4</sub>"x29<sup>3</sup>/<sub>4</sub>"



# terrazzo

GRESPLUS



terrazzo beige cm 60x60 - 23<sup>5</sup>/<sub>8</sub>"x23<sup>5</sup>/<sub>8</sub>"

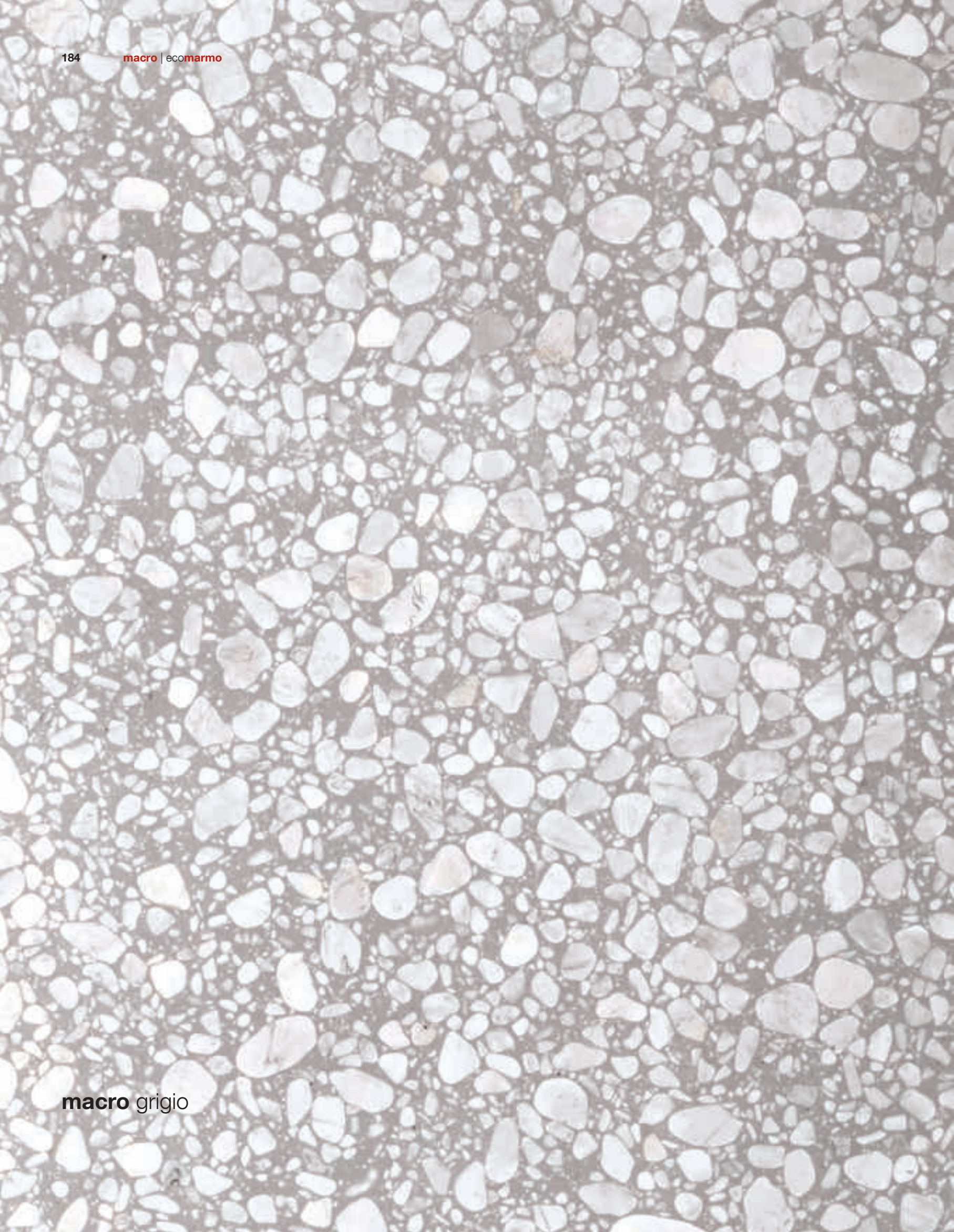

# macro

GRANITOKER



macro grigio *lucida* cm 120x120 - 47<sup>1</sup>/<sub>4</sub>"x47<sup>1</sup>/<sub>4</sub>"

## COLORI COLOURS COULEURS FARBEN

macro carnico



macro moro

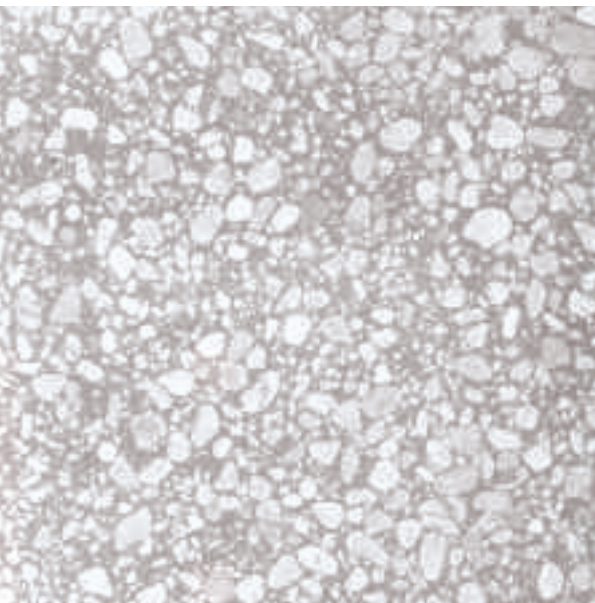
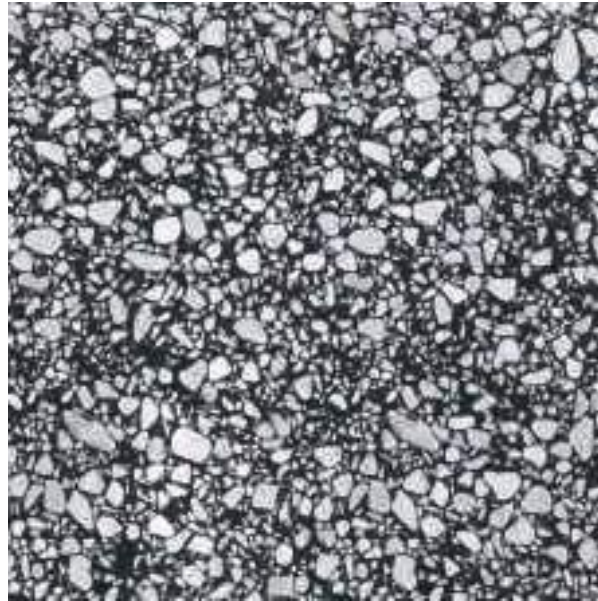





macro grigio

macro bianco

## FORMATI SIZES FORMATS FORMATE

# macro

GRANITOKER

				
<b>Formati Sizes</b> <b>Formats Formate</b>	<b>cm 60x60</b> 23 <sup>5</sup> / <sub>8</sub> "x23 <sup>5</sup> / <sub>8</sub> "	<b>cm 60x120</b> 23 <sup>5</sup> / <sub>8</sub> "x47 <sup>1</sup> / <sub>4</sub> "	<b>cm 120x120</b> 47 <sup>1</sup> / <sub>4</sub> "x47 <sup>1</sup> / <sub>4</sub> "	<b>cm 120x240</b> 47 <sup>1</sup> / <sub>4</sub> "x94 <sup>1</sup> / <sub>2</sub> "
<b>Superfici Surfaces</b> <b>Surfaces Oberflächen</b>	● ●	● ●	● ●	● ●
	mm 10	mm 10	mm 6,5	mm 6,5

K Grandi Lastre K<sub>o</sub>ntinua  
K<sub>o</sub>ntinua Big Slabs  
Grandes Dalles K<sub>o</sub>ntinua  
K<sub>o</sub>ntinua große Platten

● Naturale Matt Naturelle Matt  
● Lucida

Rettificate in un unico calibro Rectified version in a single caliber Rectifiés en un unique calibre Boden Sie in einem einzigen Kaliber

Caratteristiche tecniche e imballi a pagina: Technical features and packing on page: Caractéristiques techniques et emballages à la page: Technische Eigenschaften und Verpackungen auf Seite: **440**

## PEZZI SPECIALI TRIMS ACCESSOIRES FORMSTÜCKE

**Battiscopa Bullnose**  
**Plinthe à bord arrondi**  
**Stehsockel**  
cm 7x60- 2<sup>3</sup>/<sub>4</sub>"x23<sup>5</sup>/<sub>8</sub>"



**Gradino Step tread**  
**Nez de marche Stufenplatte**  
cm 30x60 - 11<sup>5</sup>/<sub>8</sub>"x23<sup>5</sup>/<sub>8</sub>"

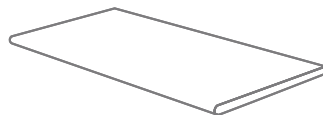

**Gradone (assemblato)**  
cm 120x33 - 47<sup>1</sup>/<sub>4</sub>"x13"

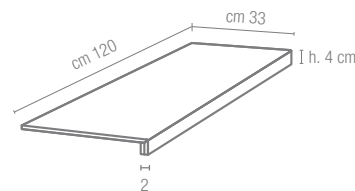

**Angolare (assemblato)**  
cm 120x33 - 47<sup>1</sup>/<sub>4</sub>"x13"

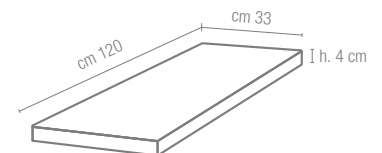



# marte

GRANITOGRES



**crema marfil** cm 60x120 - 23<sup>5</sup>/<sub>8</sub>"x47<sup>1</sup>/<sub>4</sub>"

## COLORI COLOURS COULEURS FARBEN

nero acapulco



grigio maglia



grigio marostica



emperador



ramora brown



bronzetto



# **mar**te

GRANITOGRES

raggio di luna



grigio egeo



thassos



crema marfil



palissandro



botticino

## COLORI COLOURS COULEURS FARBEN

azul bahia



azul macauba



verde guatemala

SUPERFICI SURFACES SURFACES OBERFLÄCHEN

**marte**

GRANITOGRES









**levigata**  
polished  
**polie**  
poliert

**satinata**  
satin finished  
**satinée**  
satinert

**naturale** matt  
naturelle **matt**  
**R9 A**

**bocciardata**  
bouchardée  
gehämmert  
**R11 A+B**

## FORMATI SIZES FORMATS FORMATE

Formati Sizes Formats Formate	 <b>cm 15x15</b> 5 <sup>7</sup> / <sub>8</sub> "x5 <sup>7</sup> / <sub>8</sub> "	 <b>cm 30x30</b> 11 <sup>3</sup> / <sub>4</sub> "x11 <sup>3</sup> / <sub>4</sub> "	 <b>cm 15x60</b> 5 <sup>7</sup> / <sub>8</sub> "x23 <sup>5</sup> / <sub>8</sub> "	 <b>cm 30x60</b> 11 <sup>3</sup> / <sub>4</sub> "x23 <sup>5</sup> / <sub>8</sub> "	 <b>cm 40x40**</b> 15 <sup>3</sup> / <sub>4</sub> "x15 <sup>3</sup> / <sub>4</sub> "	 <b>cm 60x60</b> 23 <sup>5</sup> / <sub>8</sub> "x23 <sup>5</sup> / <sub>8</sub> "	 <b>cm 60x120</b> 23 <sup>5</sup> / <sub>8</sub> "x47 <sup>1</sup> / <sub>4</sub> "
Superfici Surfaces Surfaces Oberflächen	●	● ● ●	● ● ●	● ● ● ●	● ●	● ● ● ●	● ●
 *	mm 9,4	mm 9,4	mm 9,4	mm 9,4	mm 9,4	mm 9,4	mm 9,4

\* Spessore su superficie naturale e satinata Thickness on matt and satined surface  
Epaisseur sur surface mat et satinée Stärke der Fliesen mit Matt - satinierten Oberfläche

\*\* Ad eccezione di: Except for: À l'exception de: Mit Ausnahme von: **Azul Bahia, Azul Macauba, Ramora Brown, Verde Guatemala**

- Naturale Matt Naturelle Matt **R9 A**  
(A richiesta On request  
Sur demande Auf Anfrage **R10**)
- Levigata Polished Polie Poliert
- Satinata Satin Finished Satinée Satiniert
- Boccia data **R11 A+B**

Rettificata in un unico calibro Rectified version in a single caliber Rectifiés en un unique calibre Boden Sie in einem einzigen Kaliber

Caratteristiche tecniche e imballi a pagina: Technical features and packing on page: Caractéristiques techniques et emballages à la page: Technische Eigenschaften und Verpackungen auf Seite: **434**



nero acapulco cm 60x60 - 23<sup>5</sup>/<sub>8</sub>"x23<sup>5</sup>/<sub>8</sub>"

## PEZZI SPECIALI TRIMS ACCESSOIRES FORMSTÜCKE

# marte

GRANITOGRES

**Battiscopa Bullnose**  
**Plinthe à bord arrondi Stehsockel**  
 cm 9x30 - 3 1/2"x11 3/4"  
 cm 9x40 - 3 1/2"x15 3/4"  
 cm 9x60 - 3 1/2"x23 5/8"

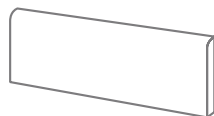

**Zoccolo a raccordo a becco civetta\***  
**Cove base with rounded edge\***  
**Plinthe à gorge bord arrondi\***  
**Hohlkehlsocbel mit abgerundeter Kante\***  
 cm 15x30 - 5 7/8"x11 3/4"

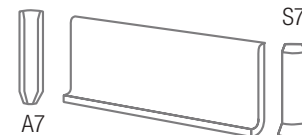

**Gradino Step tread**  
**Nez de marche Stufenplatte**  
 cm 30x30 - 11 3/4"x11 3/4"  
 cm 30x60 - 11 3/4"x23 5/8"  
 cm 30x120 - 11 3/4"x47 1/4"

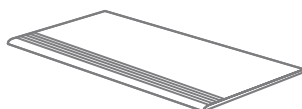

**Listello Listel**  
**Listel Zeierleiste**  
 cm 9x30 - 3 1/2"x11 3/4"  
 cm 9x40 - 3 1/2"x15 3/4"  
 cm 9x60 - 3 1/2"x23 5/8"



**Tozzetto**  
**Insert**  
**Cabochon**  
**Einleger**  
 cm 9x9 - 3 1/2"x3 1/2"



**Gradone toro con bordo antiscivolo**  
**Gradone toro with non-slip edge**  
**Gradone toro avec nez antidérapant**  
**Gradone toro mit rutschsicherer Kante**  
 cm 60x33 - 23 5/8"x13"

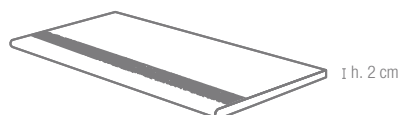

**Angolare toro con bordo antiscivolo**  
**Angolare toro with non-slip edge**  
**Angolare toro avec nez antidérapant**  
**Angolare toro mit rutschsicherer Kante**  
 cm 60x33 - 23 5/8"x13"

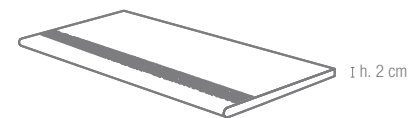

**Gradone toro**  
 cm 60x33 - 23 5/8"x13"  
 cm 120x33 - 47 1/4"x13"



**Angolare toro**  
 cm 60x33 - 23 5/8"x13"  
 cm 120x33 - 47 1/4"x13"



**Gradone (assemblato)**  
 cm 30x33 - 11 3/4"x13"  
 cm 60x33 - 23 5/8"x13"

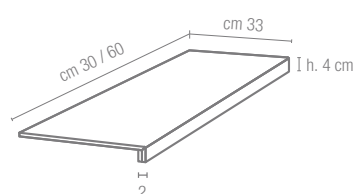

**Angolare (assemblato)**  
 cm 30x33 - 11 3/4"x13"  
 cm 60x33 - 23 5/8"x13"

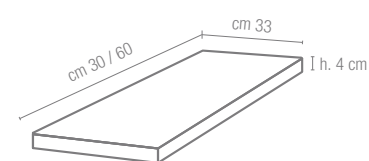

**Art. 9660 Pool Wave**  
 cm 60x25 - 23 5/8"x9 7/8"

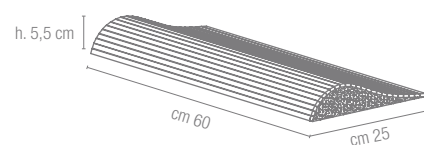

**Art. 9667 Pool Wave**  
 cm 25x29 - 9 7/8"x11 1/2"

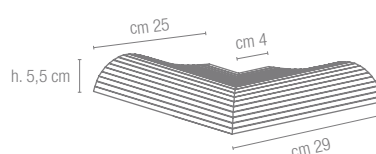

**Art. 9668 Pool Wave**  
 cm 25x29 - 9 7/8"x11 1/2"

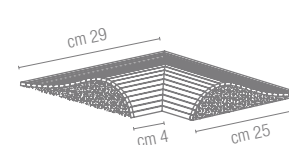

\* Non rettificato Not rectified Non rectifié Nicht rektifiziert

Produzione corrente solo nei colori: Currently produced only in the following colours: Productions courantes seulement dans les couleurs: Aktuelle Produktion nur in den Farben:

**Botticino, Bronzetto, Grigio Egeo, Nero Acapulco, Palissandro, Raggio di Luna, Thassos**

Altri colori a richiesta Other colours available on request Autres couleurs sur demande Weitere Farben auf Wunsch

## DECORI DECORS DÉCORS DEKORE

mosaico fresato\*



**cm 30x30** - 11<sup>3</sup>/<sub>4</sub>"x11<sup>3</sup>/<sub>4</sub>"  
 tessera **cm 3x3** - 1<sup>1</sup>/<sub>8</sub>"x1<sup>1</sup>/<sub>8</sub>"

Superficie naturale e levigata Matt and polished surface  
 Surface naturelle et polie Matte und polierte Oberfläche

mosaico\*



**cm 30x30** - 11<sup>3</sup>/<sub>4</sub>"x11<sup>3</sup>/<sub>4</sub>"  
 tessera **cm 3x3** - 1<sup>1</sup>/<sub>8</sub>"x1<sup>1</sup>/<sub>8</sub>"  
*su rete on net sur trame auf Netz*

Solo superficie levigata Polished surface only  
 Seulement surface polie Nur in polierter Oberfläche

mosaico texture\*

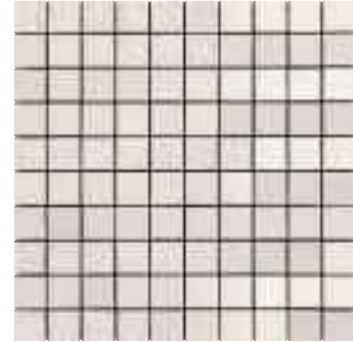

**cm 30x30** - 11<sup>3</sup>/<sub>4</sub>"x11<sup>3</sup>/<sub>4</sub>"  
 tessera **cm 3x3** - 1<sup>1</sup>/<sub>8</sub>"x1<sup>1</sup>/<sub>8</sub>"  
*su rete on net sur trame auf Netz*

Naturale, levigato, bocciardato Matt, polished, bocciardato  
 Naturel, poli, bouchardé Matt, poliert, gehämmert

listelli\*



**cm 30x30** - 11<sup>3</sup>/<sub>4</sub>"x11<sup>3</sup>/<sub>4</sub>"  
 listello **cm 3x30** - 1<sup>1</sup>/<sub>8</sub>"x11<sup>3</sup>/<sub>4</sub>"  
*su rete on net sur trame auf Netz*

Solo superficie levigata Polished surface only  
 Seulement surface polie Nur in polierter Oberfläche

listelli texture\*



**cm 30x30** - 11<sup>3</sup>/<sub>4</sub>"x11<sup>3</sup>/<sub>4</sub>"  
 listello **cm 1,5x30** - 5/8"x11<sup>3</sup>/<sub>4</sub>"  
*su rete on net sur trame auf Netz*

Naturale, levigato, bocciardato Matt, polished, bocciardato  
 Naturel, poli, bouchardé Matt, poliert, gehämmert

\* Disponibile in tutti i colori della serie Available in all the colours of the series Disponible dans tous les couleurs e la série Verfügbar in allen Farben

# **marte**

GRANITOGRES



**listelli texture thassos** cm 30x30 - 11<sup>3</sup>/<sub>4</sub>"x11<sup>3</sup>/<sub>4</sub>"  
**thassos** cm 60x120 - 23<sup>5</sup>/<sub>8</sub>"x47<sup>1</sup>/<sub>4</sub>"



## DECORI DECORS DÉCORS DEKORE

mosaico mix A\*



**cm 30x30** - 11<sup>3</sup>/<sub>4</sub>"x11<sup>3</sup>/<sub>4</sub>"  
 tessera **cm 2,2x2,2** - 7/8"x7/8"  
*su rete on net sur trame auf Netz*

bianco assoluto, azul bahia,  
 azul macauba

mosaico mix B\*



**cm 30x30** - 11<sup>3</sup>/<sub>4</sub>"x11<sup>3</sup>/<sub>4</sub>"  
 tessera **cm 2,2x2,2** - 7/8"x7/8"  
*su rete on net sur trame auf Netz*

bianco assoluto, azul bahia,  
 azul macauba, acciaio

mosaico mix C\*

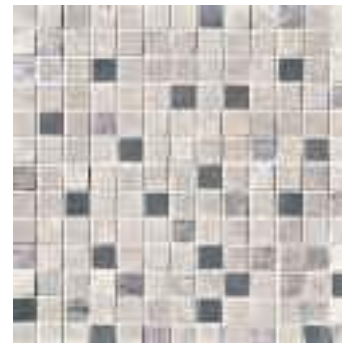

**cm 30x30** - 11<sup>3</sup>/<sub>4</sub>"x11<sup>3</sup>/<sub>4</sub>"  
 tessera **cm 2,2x2,2** - 7/8"x7/8"  
*su rete on net sur trame auf Netz*

grigio egeo, grigio maglia,  
 raggio di luna

mosaico mix D\*



**cm 30x30** - 11<sup>3</sup>/<sub>4</sub>"x11<sup>3</sup>/<sub>4</sub>"  
 tessera **cm 2,2x2,2** - 7/8"x7/8"  
*su rete on net sur trame auf Netz*

grigio egeo, grigio maglia,  
 raggio di luna, acciaio

mosaico mix F\*

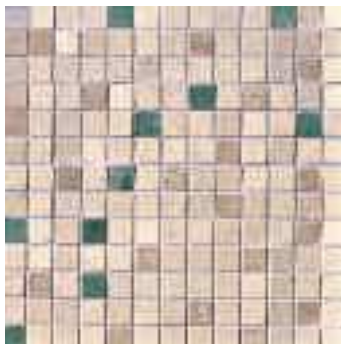

**cm 30x30** - 11<sup>3</sup>/<sub>4</sub>"x11<sup>3</sup>/<sub>4</sub>"  
 tessera **cm 2,2x2,2** - 7/8"x7/8"  
*su rete on net sur trame auf Netz*

botticino, bronzetto, palissandro,  
 verde guatemala



# **marte**

GRANITOGRES



**mosaico texture thassos** cm 30x30 - 11<sup>3</sup>/<sub>4</sub>"x11<sup>3</sup>/<sub>4</sub>"



# onici

GRANITOKER



onice miele cm 120x240 - 47<sup>1</sup>/<sub>4</sub>"x94<sup>1</sup>/<sub>2</sub>", cm 120x120 - 47<sup>1</sup>/<sub>4</sub>"x47<sup>1</sup>/<sub>4</sub>"

## COLORI COLOURS COULEURS FARBEN

onice avorio



onice bianco



onice miele



onice ghiaccio

onice quarzo

## FORMATI SIZES FORMATS FORMATE

# onici

## GRANITOKER

K Grandi Lastre Kontinua  
 K Kontinua Big Slabs  
 Grandes Dalles K Kontinua  
 Kontinua große Platten

Formati Sizes Formats Formate	<b>cm 60x60</b> 23 <sup>5</sup> / <sub>8</sub> "x23 <sup>5</sup> / <sub>8</sub> "	<b>cm 60x120</b> 23 <sup>5</sup> / <sub>8</sub> "x47 <sup>1</sup> / <sub>4</sub> "	<b>cm 90x90</b> 35 <sup>3</sup> / <sub>8</sub> "x35 <sup>3</sup> / <sub>8</sub> "	<b>cm 90x180</b> 35 <sup>3</sup> / <sub>8</sub> "x70 <sup>7</sup> / <sub>8</sub> "	<b>cm 60x120</b> 23 <sup>5</sup> / <sub>8</sub> "x47 <sup>1</sup> / <sub>4</sub> "	<b>cm 120x120</b> 47 <sup>1</sup> / <sub>4</sub> "x47 <sup>1</sup> / <sub>4</sub> "	<b>cm 120x240</b> 47 <sup>1</sup> / <sub>4</sub> "x94 <sup>1</sup> / <sub>2</sub> "	<b>cm 120x278</b> 47 <sup>1</sup> / <sub>4</sub> "x109 <sup>1</sup> / <sub>2</sub> "
Superfici Surfaces Surfaces Oberflächen	● ●	● ●	● ●	● ●	● ●	● ●	● ●	● ●
	mm 10	mm 10	mm 10	mm 10	mm 6,5	mm 6,5	mm 6,5	mm 6,5

● Naturale Matt Naturelle Matt  
 ● Lucida

Rettificate in un unico calibro Rectified version in a single caliber Rectifiés en un unique calibre Boden Sie in einem einzigen Kaliber

Caratteristiche tecniche e imballi a pagina: Technical features and packing on page: Caractéristiques techniques et emballages à la page: Technische Eigenschaften und Verpackungen auf Seite: **440**

## PEZZI SPECIALI TRIMS ACCESSOIRES FORMSTÜCKE

**Battiscopa Bullnose**  
**Plinthe à bord arrondi**  
**Stehsockel**  
**cm 7x60 - 2<sup>3</sup>/<sub>4</sub>"x23<sup>5</sup>/<sub>8</sub>"**



**Gradino Step tread**  
**Nez de marche Stufenplatte**  
**cm 30x60 - 11<sup>3</sup>/<sub>4</sub>"x23<sup>5</sup>/<sub>8</sub>"**

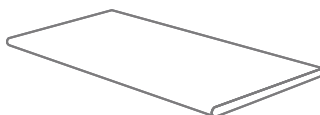

**Angolare (assemblato)**  
**cm 120x33 - 47<sup>1</sup>/<sub>4</sub>"x13"**

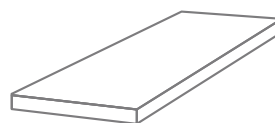

**Gradone (assemblato)**  
**cm 120x33 - 47<sup>1</sup>/<sub>4</sub>"x13"**

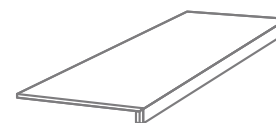

## DECORI DECORS DÉCORS DEKORE

mosaico\*



**cm 30x30** - 11<sup>3</sup>/<sub>4</sub>"x11<sup>3</sup>/<sub>4</sub>"  
tessera **cm 2,3x2,3**

*su rete on net sur trame auf Netz*



mosaico 5x10\*



**cm 30x30** - 11<sup>3</sup>/<sub>4</sub>"x11<sup>3</sup>/<sub>4</sub>"  
tessera **cm 5x10**

*su rete on net sur trame auf Netz*



\* Disponibile in tutti i colori della serie Available in all the colours of the series Disponible dans tous les couleurs e la série Verfügbar in allen Farben



onice avorio cm 120x278 - 47<sup>1</sup>/<sub>4</sub>"x109<sup>1</sup>/<sub>2</sub>"

# onici

GRANITOKER



onice ghiaccio, onice quarzo cm 120x278 - 47<sup>1</sup>/<sub>4</sub>"x109<sup>1</sup>/<sub>2</sub>"

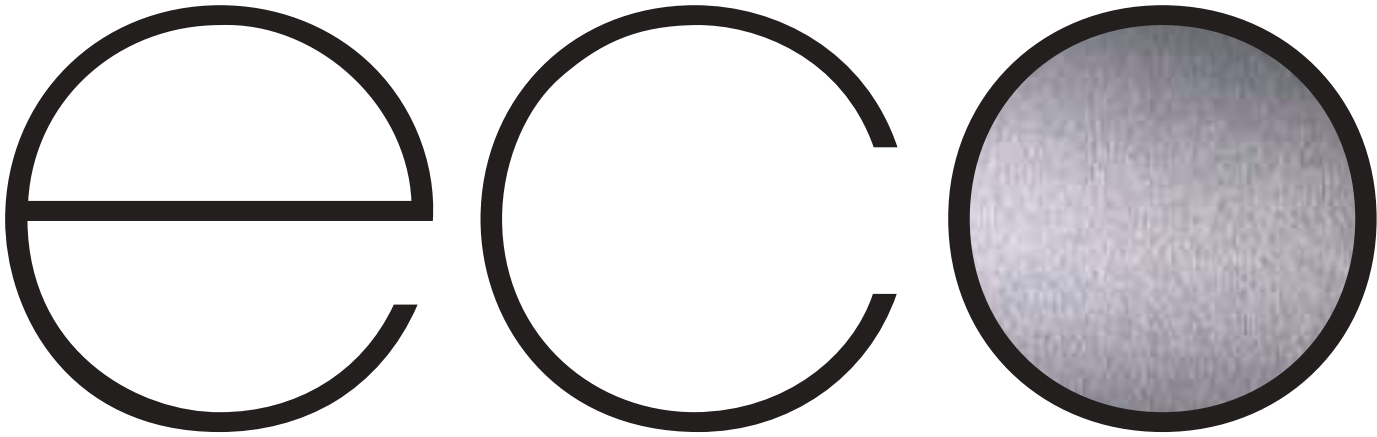



ecometal ecométal ecometall

**metallo**

# ecometallo

210 **kerinox**

214 **metallica**

220 **steeltech**

**METALLO**

Elemento chimico dotato di buona conducibilità termica ed elettrica, elevata tenacità, duttilità e malleabilità che lo qualificano come uno dei materiali maggiormente utilizzati a livello industriale. Caratterizzato dal potere riflettente e dall'opacità alla luce è in grado di formare con l'ossigeno ossidi a carattere più o meno spiccatamente basico.

**METAL**

A very strong, ductile and malleable chemical element with good thermal and electric conductivity that make it one of the most widely used materials for industrial applications. Standing out for its reflective power and opaqueness to light, it can bind to oxygen to form more or less alkaline oxides.



# kerinox

GRANITOKER



kerinox antracite *satinata* cm 90x90 - 35<sup>3</sup>/<sub>8</sub>"x35<sup>3</sup>/<sub>8</sub>"

## COLORI COLOURS COULEURS FARBEN

kerinox antracite



kerinox bianco









kerinox grigio





kerinox sabbia

## FORMATI SIZES FORMATS FORMATE

Formati Sizes Formats Formate		
	<b>cm 60x60</b> 23 <sup>5</sup> / <sub>8</sub> "x23 <sup>5</sup> / <sub>8</sub> "	<b>cm 90x90</b> 35 <sup>3</sup> / <sub>8</sub> "x35 <sup>3</sup> / <sub>8</sub> "
Superfici Surfaces Surfaces Oberflächen		
	mm 10	mm 10
 Media Medium Modérée Mittlere		

Vedi pagina: See page: Voir page : Siehe Seite: **448**

-  Grip **R11 A+B**
-  Satinata Satin Finished Satinée Satiniert
-  Lappata

Rettificate in un unico calibro Rectified version in a single caliber Rectifiés en un unique calibre Boden Sie in einem einzigen Kaliber

Caratteristiche tecniche e imballi a pagina: Technical features and packing on page: Caractéristiques techniques et emballages à la page: Technische Eigenschaften und Verpackungen auf Seite: **440**

## PEZZI SPECIALI TRIMS ACCESSOIRES FORMSTÜCKE

**Battiscopa Bullnose**  
**Plinthe à bord arrondi**  
**Stehsockel**  
cm 7x60 - 2<sup>3</sup>/<sub>4</sub>"x23<sup>5</sup>/<sub>8</sub>"  
cm 7x90 - 2<sup>3</sup>/<sub>4</sub>"x35<sup>3</sup>/<sub>8</sub>"



**Gradino Step tread**  
**Nez de marche Stufenplatte**  
cm 30x60 - 11<sup>3</sup>/<sub>4</sub>"x23<sup>5</sup>/<sub>8</sub>"  
cm 30x90 - 11<sup>3</sup>/<sub>4</sub>"x35<sup>3</sup>/<sub>8</sub>"

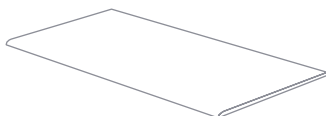

**Gradone (assemblato)**  
cm 60x33 - 23<sup>5</sup>/<sub>8</sub>"x13"  
cm 90x33 - 35<sup>3</sup>/<sub>8</sub>"x13"

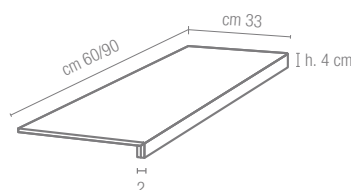

**Angolare (assemblato)**  
cm 60x33 - 23<sup>5</sup>/<sub>8</sub>"x13"  
cm 90x33 - 35<sup>3</sup>/<sub>8</sub>"x13"

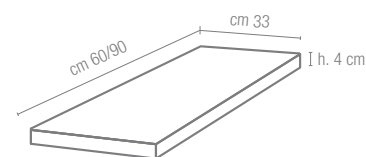

kerinox bianco lappata cm 90x90 - 35<sup>3</sup>/<sub>8</sub>"x35<sup>3</sup>/<sub>8</sub>"





# metallica

GRANITOKER



inox lappato cm 60x60 - 23<sup>5</sup>/<sub>8</sub>"x23<sup>5</sup>/<sub>8</sub>"

## COLORI COLOURS COULEURS FARBEN







inox lappato



zinco-titanio lappato



## FORMATI SIZES FORMATS FORMATE

Formati Sizes Formats Formate		
	<b>cm 30x60</b> 11 <sup>3</sup> / <sub>4</sub> "x23 <sup>5</sup> / <sub>8</sub> "	<b>cm 60x60</b> 23 <sup>5</sup> / <sub>8</sub> "x23 <sup>5</sup> / <sub>8</sub> "
Superfici Surfaces Surfaces Oberflächen		
	mm 10	mm 10
 Media Medium Modérée Mittlere		 Lappata

Vedi pagina: See page: Voir page : Siehe Seite: **448**

Rettificate in un unico calibro Rectified version in a single caliber Rectifiés en un unique calibre Boden Sie in einem einzigen Kaliber

Caratteristiche tecniche e imballi a pagina: Technical features and packing on page: Caractéristiques techniques et emballages à la page: Technische Eigenschaften und Verpackungen auf Seite: **440**

## PEZZI SPECIALI TRIMS ACCESSOIRES FORMSTÜCKE

**Battiscopa Bullnose**  
**Plinthe à bord arrondi**  
**Stehsockel**  
 cm 9x60 - 3<sup>1</sup>/<sub>2</sub>"x23<sup>5</sup>/<sub>8</sub>"



**Gradino Step tread**  
**Nez de marche Stufenplatte**  
 cm 30x60 - 11<sup>3</sup>/<sub>4</sub>"x23<sup>5</sup>/<sub>8</sub>"

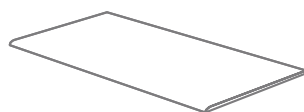

**Gradone (assemblato)**  
 cm 60x33 - 23<sup>5</sup>/<sub>8</sub>"x13"

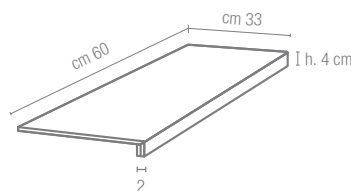

**Angolare (assemblato)**  
 cm 60x33 - 23<sup>5</sup>/<sub>8</sub>"x13"

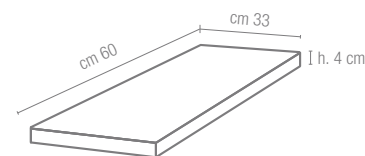

zinco-titanio lappato cm 60x60 - 23<sup>5</sup>/<sub>8</sub>"x23<sup>5</sup>/<sub>8</sub>"



## DECORI DECORS DÉCORS DEKORE

mosaico inox lappato



cm 30x30 - 11<sup>3</sup>/<sub>4</sub>"x11<sup>3</sup>/<sub>4</sub>"  
tessera cm 2,2x2,2- 2<sup>7</sup>/<sub>8</sub>"x2<sup>7</sup>/<sub>8</sub>"  
*su rete on net sur trame auf Netz*

decoro A\*

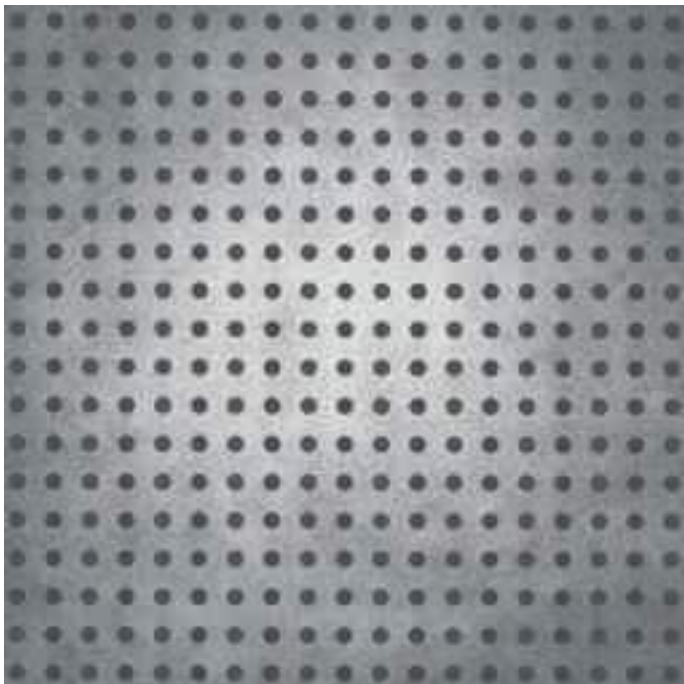

cm 60x60 - 23<sup>5</sup>/<sub>8</sub>"x23<sup>5</sup>/<sub>8</sub>"

decoro B\*



cm 60x60 - 23<sup>5</sup>/<sub>8</sub>"x23<sup>5</sup>/<sub>8</sub>"

\* Disponibile in tutti i colori della serie Available in all the colours of the series Disponible dans tous les couleurs de la série Verfügbar in allen Farben

# metallica

GRANITOKER



zinco-titanio lappato cm 60x60 - 23<sup>5</sup>/<sub>8</sub>"x23<sup>5</sup>/<sub>8</sub>"



# steeltech

GRANITOKER



steeltech corten *lappata*, steeltech beige cm 90x90 - 35<sup>3</sup>/<sub>8</sub>"x35<sup>3</sup>/<sub>8</sub>"

## COLORI COLOURS COULEURS FARBEN

steeltech antracite



steeltech corten



steeltech grigio

















steeltech beige



## FORMATI SIZES FORMATS FORMATE

steeltech

GRANITOKER

Formati Sizes Formats Formate					
	<b>cm 30x60</b> 11 <sup>3</sup> / <sub>4</sub> "x23 <sup>5</sup> / <sub>8</sub> "	<b>cm 60x60</b> 23 <sup>5</sup> / <sub>8</sub> "x23 <sup>5</sup> / <sub>8</sub> "	<b>cm 45x90</b> 17 <sup>3</sup> / <sub>4</sub> "x35 <sup>3</sup> / <sub>8</sub> "	<b>cm 90x90</b> 35 <sup>3</sup> / <sub>8</sub> "x35 <sup>3</sup> / <sub>8</sub> "	<b>cm 60x120</b> 23 <sup>5</sup> / <sub>8</sub> "x47 <sup>1</sup> / <sub>4</sub> "
Superfici Surfaces Surfaces Oberflächen					
	mm 10	mm 10	mm 10	mm 10	mm 10
 Media Medium Modérée Mittlere					 Naturale Matt Naturelle Matt R9  Lappata

Vedi pagina: See page: Voir page : Siehe Seite: 448

Rettificate in un unico calibro Rectified version in a single caliber Rectifiés en un unique calibre Boden Sie in einem einzigen Kaliber

Caratteristiche tecniche e imballi a pagina: Technical features and packing on page: Caractéristiques techniques et emballages à la page: Technische Eigenschaften und Verpackungen auf Seite: 440

## PEZZI SPECIALI TRIMS ACCESSOIRES FORMSTÜCKE

**Battiscopa Bullnose**  
Plinthe à bord arrondi  
Stehsockel  
cm 9x60 - 3<sup>1</sup>/<sub>2</sub>"x23<sup>5</sup>/<sub>8</sub>"  
cm 9x90 - 3<sup>1</sup>/<sub>2</sub>"x35<sup>3</sup>/<sub>8</sub>"



**Gradino Step tread**  
Nez de marche Stufenplatte  
cm 30x60 - 11<sup>3</sup>/<sub>4</sub>"x23<sup>5</sup>/<sub>8</sub>"  
cm 30x90 - 11<sup>3</sup>/<sub>4</sub>"x35<sup>3</sup>/<sub>8</sub>"  
cm 30x120 - 11<sup>3</sup>/<sub>4</sub>"x47<sup>1</sup>/<sub>4</sub>"

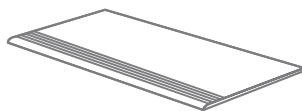

**Gradone (assemblato)**  
cm 90x33 - 35<sup>3</sup>/<sub>8</sub>"x13"

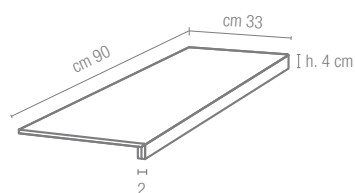

**Angolare (assemblato)**  
cm 90x33 - 35<sup>3</sup>/<sub>8</sub>"x13"

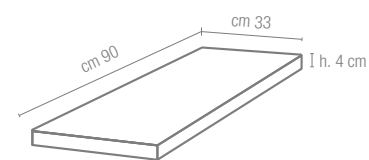
steeltech antracite cm 90x90 - 35<sup>3</sup>/<sub>8</sub>"x35<sup>3</sup>/<sub>8</sub>"

## DECORI DECORS DÉCORS DEKORE

decoro steeltech\*

**cm 90x90** -  $35\frac{3}{8}$ "x $35\frac{3}{8}$ "

Superficie naturale e lappata Matt and lappata surface  
Surface naturelle et lappata Matt und lappata Oberfläche

mosaico 6x6\*



**cm 30x30** -  $11\frac{3}{4}$ "x $11\frac{3}{4}$ "  
tessera **cm 6x6** -  $2\frac{3}{8}$ "x $2\frac{3}{8}$ "  
*su rete on net sur trame auf Netz*

Superficie naturale e lappata  
Matt and lappata surface  
Surface naturelle et lappata  
Matt und lappata Oberfläche

# steeltech

GRANITOKER

pierre cordin

steeltech grigio lappata cm 90x90 - 35<sup>3</sup>/<sub>8</sub>"x35<sup>3</sup>/<sub>8</sub>"  
decoro steeltech corten lappata cm 90x90 - 35<sup>3</sup>/<sub>8</sub>"x35<sup>3</sup>/<sub>8</sub>"

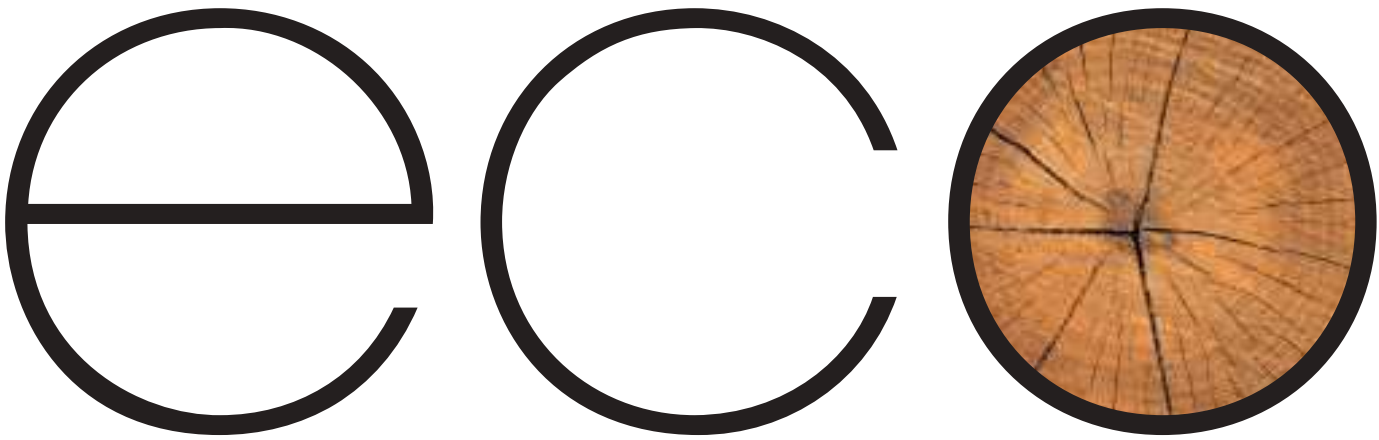

ecowood écobois ökoholz

legno

# ecolegno

- 230 **country wood**
- 236 **class wood**
- 240 **geowood**
- 244 **tavolato**
- 250 **planks**
- 254 **limpha**
- 258 **ulivo**
- 264 **newood**
- 270 **metalwood**

**LEGNO**

Insieme dei tessuti vegetali [xilema] che formano la parte solida del fusto, dei rami e delle radici degli alberi. La parte più vecchia e più interna del tronco è detta durame, la parte più giovane e periferica albarno. Il legno sin dall'antichità ha trovato notevoli applicazioni nella produzione della carta, nell'edilizia, nell'industria manifatturiera.

**WOOD**

The group of vegetable tissues [xylem] that form the solid part of the tree trunk, branches and roots. The oldest and innermost part of the trunk is also known as hardwood, while the youngest and outermost part of the trunk is known as sapwood. Since antiquity, wood has been widely used to make paper, in the building and manufacturing industries, in design.





# country wood

GRANITOKER



country greige cm 20x120 - 77/8"x47 1/4"

## COLORI COLOURS COULEURS FARBEN

country tortora



country marrone



country greige



country bianco







country ice



FORMATI SIZES FORMATS FORMATE

# country wood

GRANITOKER

				
<b>Formati Sizes</b> <b>Formats Formate</b>	<b>cm 20x120</b> 7 <sup>7</sup> / <sub>8</sub> "x47 <sup>1</sup> / <sub>4</sub> "	<b>cm 40x120</b> 15 <sup>3</sup> / <sub>4</sub> "x47 <sup>1</sup> / <sub>4</sub> "	<b>cm 60x120</b> 23 <sup>5</sup> / <sub>8</sub> "x47 <sup>1</sup> / <sub>4</sub> "	<b>cm 25x151</b> 9 <sup>7</sup> / <sub>8</sub> "x59 <sup>1</sup> / <sub>2</sub> "
<b>Superfici Surfaces</b> <b>Surfaces Oberflächen</b>	● ●	●	● ●	● ●
	mm 9	mm 20	mm 9	mm 10



- Naturale Matt Naturelle Matt **R10**
- Grip **R11 A+B**

Vedi pagina: See page: Voir page : Siehe Seite: **448**

Rettificate in un unico calibro Rectified version in a single caliber Rectifiés en un unique calibre Boden Sie in einem einzigen Kaliber

Caratteristiche tecniche e imballi a pagina: Technical features and packing on page: Caractéristiques techniques et emballages à la page: Technische Eigenschaften und Verpackungen auf Seite: **440**

## PEZZI SPECIALI TRIMS ACCESSOIRES FORMSTÜCKE

▲ 2pcs  45°

**Battiscopa Bullnose**  
**Plinthe à bord arrondi**  
**Stehsockel**  
cm 7x120 - 2<sup>3</sup>/<sub>4</sub>"x47<sup>1</sup>/<sub>4</sub>"



**Gradino Step tread**  
**Nez de marche Stufenplatte**  
cm 30x120 - 11<sup>3</sup>/<sub>4</sub>"x47<sup>1</sup>/<sub>4</sub>"

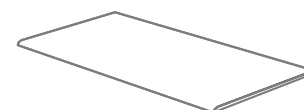

**Art. 9690**  
cm 20x120 - 7<sup>7</sup>/<sub>8</sub>"x47<sup>1</sup>/<sub>4</sub>"

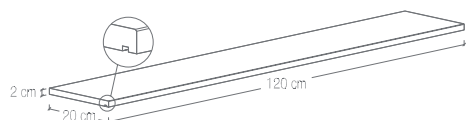

**Art. 9691 ▲**  
cm 60x60 - 23<sup>5</sup>/<sub>8</sub>"x23<sup>5</sup>/<sub>8</sub>"

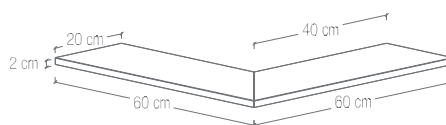

**Art. 9692 ▲**  
cm 60x60 - 23<sup>5</sup>/<sub>8</sub>"x23<sup>5</sup>/<sub>8</sub>"

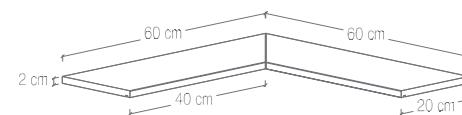

**Art. 9685 Griglia**  
cm 13x40 - 5<sup>1</sup>/<sub>8</sub>"x15<sup>3</sup>/<sub>4</sub>"



**Art. 9686 Griglia angolare ▲**  
cm 13x40 - 5<sup>1</sup>/<sub>8</sub>"x15<sup>3</sup>/<sub>4</sub>"

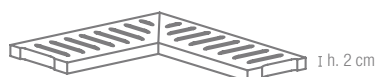

## DECORI DECORS DÉCORS DEKORE

## chevron A\*

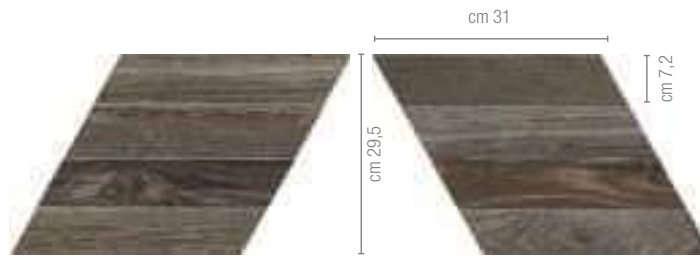

cm 31x29,5 - 12<sup>1</sup>/<sub>4</sub>"x11<sup>5</sup>/<sub>8</sub>" dx / sx  
*su rete on net sur trame auf Netz*



country marrone cm 20x120 - 7<sup>7</sup>/<sub>8</sub>"x47<sup>1</sup>/<sub>4</sub>"  
cm 25x151 - 9<sup>7</sup>/<sub>8</sub>"x59<sup>1</sup>/<sub>2</sub>"

# country wood

GRANITOKER

ur best



country bianco cm 20x120 - 7<sup>7</sup>/<sub>8</sub>"x47<sup>1</sup>/<sub>4</sub>",  
cm 25x151 - 9<sup>7</sup>/<sub>8</sub>"x59<sup>1</sup>/<sub>2</sub>"



# class wood

GRANITOKER



class grey cm 20x120 - 7<sup>7</sup>/<sub>8</sub>"x47<sup>1</sup>/<sub>4</sub>"

## COLORI COLOURS COULEURS FARBEN

class walnut



class brown



class grey



class dove grey





## FORMATI SIZES FORMATS FORMATE

# class wood

GRANITOKER

Formati Sizes  
Formats Formate



**cm 20x120**  
7<sup>7</sup>/<sub>8</sub>"x47<sup>1</sup>/<sub>4</sub>"



**cm 60x120**  
23<sup>5</sup>/<sub>8</sub>"x47<sup>1</sup>/<sub>4</sub>"

Superfici Surfaces  
Surfaces Oberflächen



mm 9

mm 9



Media  
Medium  
Modérée  
Mittlere

Vedi pagina: See page: Voir page : Siehe Seite: **448**

● Naturale Matt Naturelle Matt **R10 A**

Rettificate in un unico calibro Rectified version in a single caliber Rectifiés en un unique calibre Boden Sie in einem einzigen Kaliber

Caratteristiche tecniche e imballi a pagina: Technical features and packing on page: Caractéristiques techniques et emballages à la page: Technische Eigenschaften und Verpackungen auf Seite: **440**

## PEZZI SPECIALI TRIMS ACCESSOIRES FORMSTÜCKE

**Battiscopa Bullnose**  
**Plinthe à bord arrondi**  
**Stehsockel**  
cm 7x120 - 2<sup>3</sup>/<sub>4</sub>"x47<sup>1</sup>/<sub>4</sub>"



**Gradino Step tread**  
**Nez de marche Stufenplatte**  
cm 30x120 - 11<sup>3</sup>/<sub>4</sub>"x47<sup>1</sup>/<sub>4</sub>"

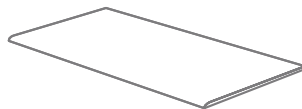

**Gradone (assemblato)**  
cm 120x33 - 47<sup>1</sup>/<sub>4</sub>"x13"

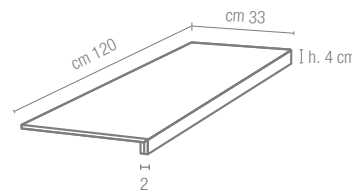

**Angolare (assemblato)**  
cm 120x33 - 47<sup>1</sup>/<sub>4</sub>"x13"

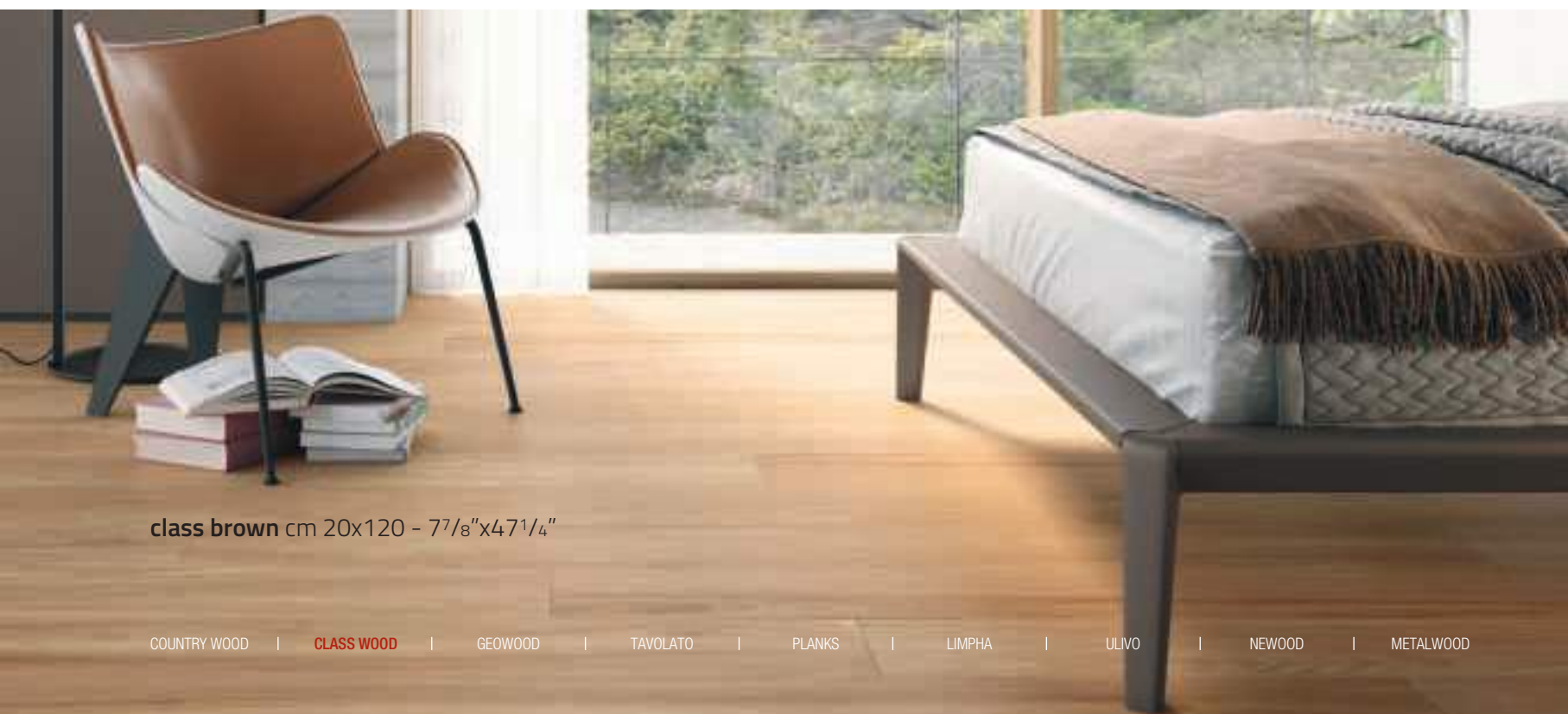
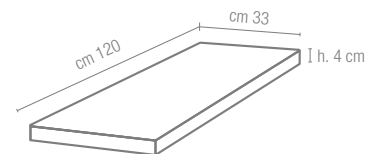

**class brown** cm 20x120 - 7<sup>7</sup>/<sub>8</sub>"x47<sup>1</sup>/<sub>4</sub>"

**geowood** white oak

# geowood

GRANITOKER



**white oak** cm 22,5x180 - 8<sup>7</sup>/<sub>8</sub>"x70<sup>7</sup>/<sub>8</sub>"

## COLORI COLOURS COULEURS FARBEN

koa



iroko



amazique



zebrawood



white oak



## FORMATI SIZES FORMATS FORMATE

# geowood



GRANITOKER

Formati Sizes  
Formats Formate

cm 22,5x180  
87/8"x707/8"

Superfici Surfaces  
Surfaces Oberflächen



mm 10



Media  
Medium  
Modérée  
Mittlere

Vedi pagina: See page: Voir page : Siehe Seite: **448**

● Naturale Matt Naturelle Matt **R9**  
● Grip **R11**

Rettificate in un unico calibro Rectified version in a single caliber Rectifiés en un unique calibre Boden Sie in einem einzigen Kaliber

Caratteristiche tecniche e imballi a pagina: Technical features and packing on page: Caractéristiques techniques et emballages à la page: Technische Eigenschaften und Verpackungen auf Seite: **440**

## PEZZI SPECIALI TRIMS ACCESSOIRES FORMSTÜCKE

**Battiscopa Bullnose**  
**Plinthe à bord arrondi**  
**Stehsockel**

cm 9x180 - 31/2"x707/8"



zebrawood cm 22,5x180 - 87/8"x707/8"

**tavolato** sbiancato

# tavolato

GRANITOKER



**tavolato sbiancato** cm 15x120 - 5<sup>7</sup>/<sub>8</sub>"x47<sup>1</sup>/<sub>4</sub>", 20x120 - 7<sup>7</sup>/<sub>8</sub>"x47<sup>1</sup>/<sub>4</sub>", 30x120 - 11<sup>3</sup>/<sub>4</sub>"x47<sup>1</sup>/<sub>4</sub>"

## COLORI COLOURS COULEURS FARBEN

tavolato  
antracitetavolato  
marrone scurotavolato  
marrone mediotavolato  
marrone chiarotavolato  
grano



FORMATI SIZES FORMATS FORMATE

# tavolato

GRANITOKER

tavolato  
sbiancato



Formati Sizes Formats Formate	<b>cm 15x91</b> 5 <sup>7</sup> / <sub>8</sub> "x35 <sup>3</sup> / <sub>4</sub> "	<b>cm 15x120</b> 5 <sup>7</sup> / <sub>8</sub> "x47 <sup>1</sup> / <sub>4</sub> "	<b>cm 20x120</b> 7 <sup>7</sup> / <sub>8</sub> "x47 <sup>1</sup> / <sub>4</sub> "	<b>cm 30x120</b> 11 <sup>3</sup> / <sub>4</sub> "x47 <sup>1</sup> / <sub>4</sub> "	<b>cm 60x120</b> 23 <sup>5</sup> / <sub>8</sub> "x47 <sup>1</sup> / <sub>4</sub> "
Superfici Surfaces Surfaces Oberflächen	●	●	●	●	●
	mm 8,5*	mm 9	mm 9 mm 9*▲	mm 9	mm 9



● Naturale Matt Naturelle Matt R9

Vedi pagina: See page: Voir page : Siehe Seite: **448**

Rettificate in un unico calibro Rectified version in a single caliber Rectifiés en un unique calibre Boden Sie in einem einzigen Kaliber

\* Non rettificato Unrectified Non rectifié Nicht kalibriert

▲ Solo nei colori: Only in the colours: Seulement dans les couleurs: Nur in die Farben: **Marrone chiaro, Marrone medio, Grano, Sbiancato**

Caratteristiche tecniche e imballi a pagina: Technical features and packing on page:

Caractéristiques techniques et emballages à la page: Technische Eigenschaften und Verpackungen auf Seite: **440**

## PEZZI SPECIALI TRIMS ACCESSOIRES FORMSTÜCKE

**Battiscopa Bullnose**  
Plinthe à bord arrondi  
Stehssockel  
cm 7x120 - 3<sup>3</sup>/<sub>4</sub>"x47<sup>1</sup>/<sub>4</sub>"



**Gradino Step tread**  
Nez de marche Stufenplatte  
cm 30x120 - 11<sup>3</sup>/<sub>4</sub>"x47<sup>1</sup>/<sub>4</sub>"

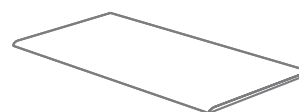

**Gradone (assemblato)**  
cm 120x33 - 47<sup>1</sup>/<sub>4</sub>"x13"

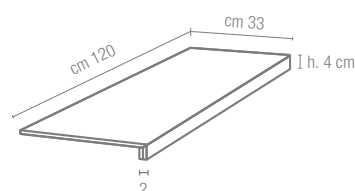

**Angolare (assemblato)**  
cm 120x33 - 47<sup>1</sup>/<sub>4</sub>"x13"

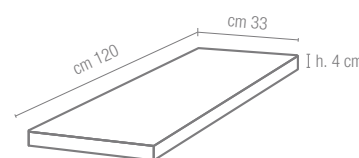

## DECORI DECORS DÉCORS DEKORE

cassettone tavolato A\*



cm 60x60 - 23<sup>5</sup>/<sub>8</sub>"x23<sup>5</sup>/<sub>8</sub>"

chevron B\*

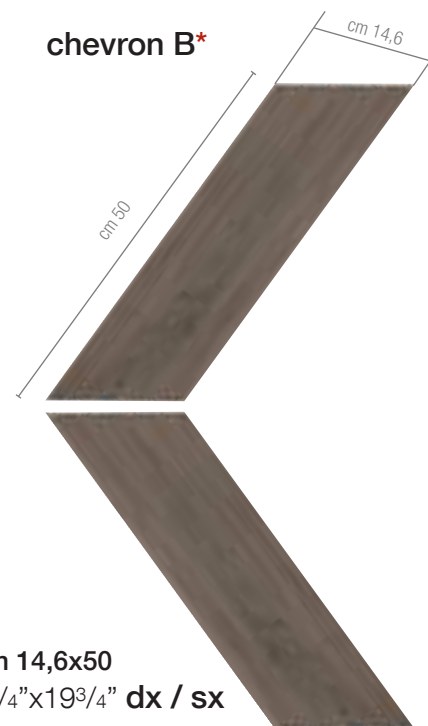

cm 14,6x50  
5<sup>3</sup>/<sub>4</sub>"x19<sup>3</sup>/<sub>4</sub>" dx / sx

chevron A\*

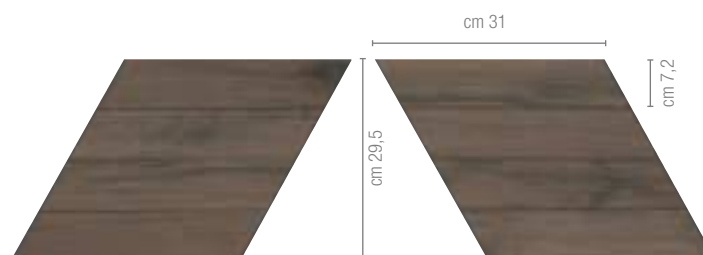

cm 31x29,5 - 12<sup>1</sup>/<sub>4</sub>"x11<sup>5</sup>/<sub>8</sub>" dx / sx  
su rete on net sur trame auf Netz

\* Disponibile in tutti i colori della serie Available in all the colours of the series Disponible dans tous les couleurs e la série Verfügbar in allen Farben

# tavolato

GRANITOKER

**cassettone tavolo A marrone scuro** cm 60x60 -  $23\frac{5}{8}'' \times 23\frac{5}{8}''$ ;  
**tavolato marrone scuro** cm 15x120 -  $5\frac{7}{8}'' \times 47\frac{1}{4}''$ , cm 20x120 -  $7\frac{7}{8}'' \times 47\frac{1}{4}''$ , cm 30x120 -  $11\frac{3}{4}'' \times 47\frac{1}{4}''$



# planks

GRANITOKER



planks beige cm 20x240 - 7<sup>7</sup>/<sub>8</sub>"x94<sup>1</sup>/<sub>2</sub>", cm 30x240 - 11<sup>3</sup>/<sub>4</sub>"x94<sup>1</sup>/<sub>2</sub>"

## COLORI COLOURS COULEURS FARBEN

planks grigio



planks bruno



planks muschio



planks bianco



planks beige







# FORMATI SIZES FORMATS FORMATE

# planks

GRANITOKER

K Grandi Lastre KONTINUA  
 KONTINUA Big Slabs  
 Grandes Dalles KONTINUA  
 KONTINUA große Platten

				
Formati Sizes Formats Formate	<b>cm 20x120</b> 7 <sup>7</sup> / <sub>8</sub> "x47 <sup>1</sup> / <sub>4</sub> "	<b>cm 30x120</b> 11 <sup>3</sup> / <sub>4</sub> "x47 <sup>1</sup> / <sub>4</sub> "	<b>cm 20x240</b> 7 <sup>7</sup> / <sub>8</sub> "x94 <sup>1</sup> / <sub>2</sub> "	<b>cm 30x240</b> 11 <sup>3</sup> / <sub>4</sub> "x94 <sup>1</sup> / <sub>2</sub> "
Superfici Surfaces Surfaces Oberflächen	●	●	●	●
	mm 6,5	mm 6,5	mm 6,5	mm 6,5



● Naturale Matt Naturelle Matt

Vedi pagina: See page: Voir page : Siehe Seite: **448**

Rettificate in un unico calibro Rectified version in a single caliber Rectifiés en un unique calibre Boden Sie in einem einzigen Kaliber

Caratteristiche tecniche e imballi a pagina: Technical features and packing on page: Caractéristiques techniques et emballages à la page: Technische Eigenschaften und Verpackungen auf Seite: **440**

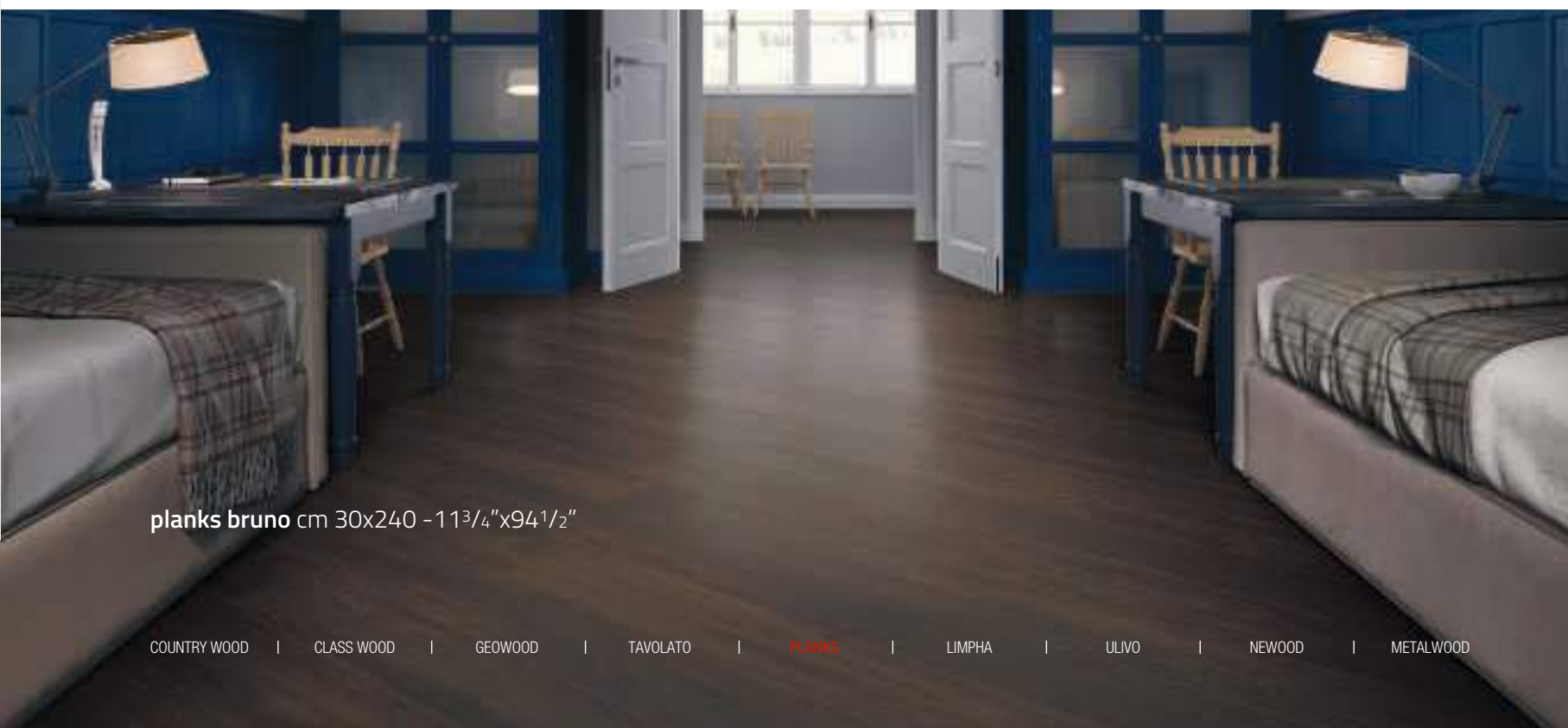

planks bruno cm 30x240 - 11<sup>3</sup>/<sub>4</sub>"x94<sup>1</sup>/<sub>2</sub>"



limpha coral rose



# limpha

GRANITOKER



coral rose cm 120x240 - 47 1/4"x94 1/2"

## COLORI COLOURS COULEURS FARBEN

arborea



gelsomino



coral rose



helix



## FORMATI SIZES FORMATS FORMATE

**limpha**  
GRANITOKER

K Grandi Lastre K<sub>ontinua</sub>  
K<sub>ontinua</sub> Big Slabs  
Grandes Dalles K<sub>ontinua</sub>  
K<sub>ontinua</sub> große Platten

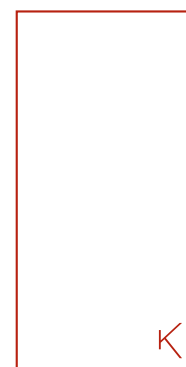

Formati Sizes  
Formats Formate

**cm 120x240**  
47 1/4" x 94 1/2"

Superfici Surfaces  
Surfaces Oberflächen



mm 6,5



● Naturale Matt Naturelle Matt

Vedi pagina: See page: Voir page : Siehe Seite: **448**

Rettificate in un unico calibro Rectified version in a single caliber Rectifiés en un unique calibre Boden Sie in einem einzigen Kaliber

Caratteristiche tecniche e imballi a pagina: Technical features and packing on page: Caractéristiques techniques et emballages à la page: Technische Eigenschaften und Verpackungen auf Seite: **440**

Ogni lastra è unica e diversa dalle altre, ma il particolare disegno grafico consente che se affiancate, si uniscano su ogni lato senza soluzione di continuità, formando un disegno unico e omogeneo.

Every tile is unique and different from the next, but, thanks to the distinctive pattern, once laid, they create a unique design and seamless effect.

Chaque dalle est unique et différente des autres. Si elles sont mises côte à côte, elles s'unissent de chaque côté sans solution de continuité. Le motif graphique particulier permet ainsi de créer un dessin unique et homogène.

Jede Platte ist einzigartig und unterscheidet sich von den anderen. Dennoch ermöglicht das besondere grafische Design ein nahtloses Aneinanderfügen auf jeder Seite und eine einheitliche, homogene Gestaltung.

**bios.**  
**ceramics®**

La collezione Limpha è disponibile anche nella versione senza trattamento Bios Ceramics®. La preferenza andrà espressa al momento dell'ordine.

The Limpha collection is available also in the version without the Bios Ceramics® treatment. You can express your preference upon placing your order.

La collection Limpha est également disponible dans la version sans traitement Bios Ceramics®. La préférence devra être exprimée lors de la commande.

Die kollektion limpha ist auch ohne bios ceramics®-behandlung erhältlich. Die entsprechende entscheidung wird bei der bestellung getroffen.



# ulivo

GRANITOKER



**ulivo noce** cm 20x120 - 7<sup>7</sup>/<sub>8</sub>"x47<sup>1</sup>/<sub>4</sub>", 30x120 - 11<sup>3</sup>/<sub>4</sub>"x47<sup>1</sup>/<sub>4</sub>"

## COLORI COLOURS COULEURS FARBEN

ulivo grigio



ulivo tortora



ulivo noce



ulivo panna



## FORMATI SIZES FORMATS FORMATE

# ulivo

GRANITOKER

<b>Formati Sizes</b> <b>Formats Formate</b>	<b>cm 20x120</b> 7 <sup>7</sup> / <sub>8</sub> "x47 <sup>1</sup> / <sub>4</sub> "	<b>cm 30x120</b> 11 <sup>3</sup> / <sub>4</sub> "x47 <sup>1</sup> / <sub>4</sub> "	<b>cm 60x120</b> 23 <sup>5</sup> / <sub>8</sub> "x47 <sup>1</sup> / <sub>4</sub> "
<b>Superfici Surfaces</b> <b>Surfaces Oberflächen</b>	●	●	●
	mm 9	mm 9	mm 9



Accentuata  
Accentuated  
Importante  
Starke

Vedi pagina: See page: Voir page : Siehe Seite: **448**

● Naturale Matt Naturelle Matt **R10**

Rettificate in un unico calibro Rectified version in a single caliber Rectifiés en un unique calibre Boden Sie in einem einzigen Kaliber

Caratteristiche tecniche e imballi a pagina: Technical features and packing on page: Caractéristiques techniques et emballages à la page: Technische Eigenschaften und Verpackungen auf Seite: **440**

## PEZZI SPECIALI TRIMS ACCESSOIRES FORMSTÜCKE

**Battiscopa Bullnose**  
**Plinthe à bord arrondi**  
**Stehsockel**  
cm 7x120 - 2<sup>3</sup>/<sub>4</sub>"x47<sup>1</sup>/<sub>4</sub>"



**Gradino Step tread**  
**Nez de marche Stufenplatte**  
cm 30x120 - 11<sup>3</sup>/<sub>4</sub>"x47<sup>1</sup>/<sub>4</sub>"

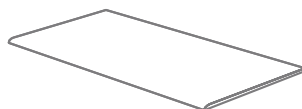

**Gradone (assemblato)**  
cm 120x33 - 47<sup>1</sup>/<sub>4</sub>"x13"

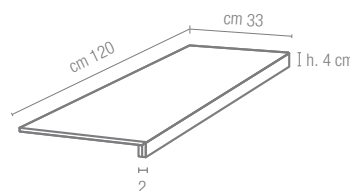

**Angolare (assemblato)**  
cm 120x33 - 47<sup>1</sup>/<sub>4</sub>"x13"

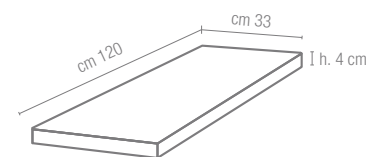

ulivo grigio, ulivo panna cm 20x120 - 7<sup>7</sup>/<sub>8</sub>"x47<sup>1</sup>/<sub>4</sub>"

## DECORI DECORS DÉCORS DEKORE

chevron A\*

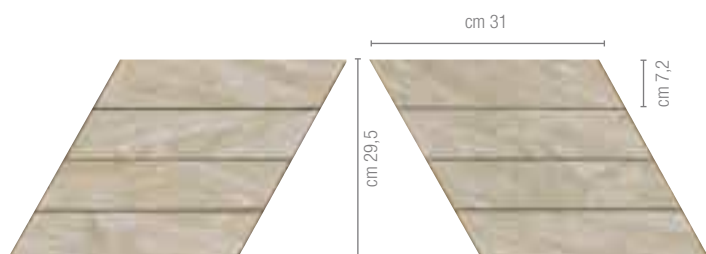

**cm 31x29,5 - 12<sup>1</sup>/<sub>4</sub>"x11<sup>5</sup>/<sub>8</sub>" dx / sx**  
*su rete on net sur trame auf Netz*

chevron B\*

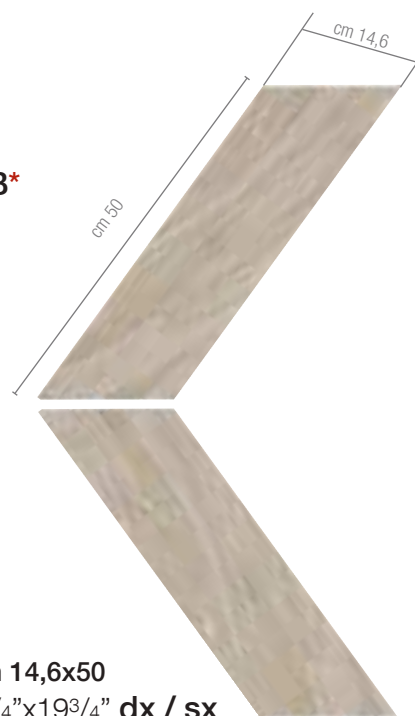

**cm 14,6x50**  
**5<sup>3</sup>/<sub>4</sub>"x19<sup>3</sup>/<sub>4</sub>" dx / sx**

\* Disponibile in tutti i colori della serie Available in all the colours of the series Disponible dans tous les couleurs e la série Verfügbar in allen farben



**ulivo panna chevron B**  
**cm 14,6x50 - 5<sup>3</sup>/<sub>4</sub>"x19<sup>3</sup>/<sub>4</sub>"**



# ulivo

GRANITOKER



ulivo tortora cm 20x120 - 77/8"x47 1/4"



# newood

GRANITOKER



**newood grey, newood black** cm 15x120 - 5<sup>7</sup>/<sub>8</sub>"x47<sup>1</sup>/<sub>4</sub>" , cm 20x120 - 7<sup>7</sup>/<sub>8</sub>"x47<sup>1</sup>/<sub>4</sub>" , cm 15x90 - 5<sup>7</sup>/<sub>8</sub>"x35<sup>3</sup>/<sub>8</sub>"

## COLORI COLOURS COULEURS FARBEN

newood black



newood grey



newood wengé



newood brown



newood cream



# newood

GRANITOKER

newood beige



newood ivory



newood white



## FORMATI SIZES FORMATS FORMATE

Formati Sizes Formats Formate	cm 11x90 4 <sup>3</sup> / <sub>8</sub> "x35 <sup>3</sup> / <sub>8</sub> "	cm 15x90 5 <sup>7</sup> / <sub>8</sub> "x35 <sup>3</sup> / <sub>8</sub> "	cm 22,5x90 8 <sup>7</sup> / <sub>8</sub> "x35 <sup>3</sup> / <sub>8</sub> "	cm 45x90 17 <sup>3</sup> / <sub>4</sub> "x35 <sup>3</sup> / <sub>8</sub> "	cm 15x120 5 <sup>7</sup> / <sub>8</sub> "x47 <sup>1</sup> / <sub>4</sub> "	cm 20x120 7 <sup>7</sup> / <sub>8</sub> "x47 <sup>1</sup> / <sub>4</sub> "	cm 60x120 7 <sup>7</sup> / <sub>8</sub> "x47 <sup>1</sup> / <sub>4</sub> "
Superfici Surfaces Surfaces Oberflächen	● ●	●	●	●	● ●	● ●	● ●
	mm 9	mm 9	mm 9	mm 9	mm 9	mm 9 mm 9 <sup>*▲</sup>	mm 9



Media  
Medium  
Moderée  
Mittlere

Vedi pagina: See page: Voir page: Siehe Seite: 448

● Naturale Matt Naturelle Matt R 10 A+B

● Outdoor R 11 A+B+C

Disponibile nei colori: Available in the colours:

Disponibile dans les couleurs: Verfügbar in den folgenden Farben:  
**Brown, Cream, Grey, Wengé.**

Rettificate in un unico calibro Rectified version in a single caliber Rectifiés en un unique calibre Boden Sie in einem einzigen Kaliber

\* Non rettificato Unrectified Non rectifié Nicht kalibriert

▲ Solo nei colori: Only in the colours: Seulement dans les couleurs: Nur in die Farben: **Beige, Brown, Ivory, White**

Caratteristiche tecniche e imballi a pagina: Technical features and packing on page: Caractéristiques techniques et emballages à la page: Technische Eigenschaften und Verpackungen auf Seite: 440

## PEZZI SPECIALI TRIMS ACCESSOIRES FORMSTÜCKE

**Battiscopa Bullnose**  
Plinthe à bord arrondi  
Stehsockel

cm 9x90 - 3<sup>1</sup>/<sub>2</sub>"x35<sup>3</sup>/<sub>8</sub>"  
cm 7x120 - 2<sup>3</sup>/<sub>4</sub>"x47<sup>1</sup>/<sub>4</sub>"



**Gradino Step tread**  
Nez de marche Stufenplatte

cm 30x120 - 11<sup>3</sup>/<sub>4</sub>"x47<sup>1</sup>/<sub>4</sub>"

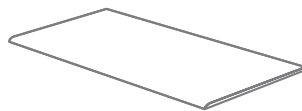

**Gradone (assemblato)**  
cm 120x33 - 47<sup>1</sup>/<sub>4</sub>"x13"

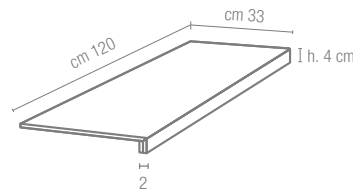

**Angolare (assemblato)**  
cm 120x33 - 47<sup>1</sup>/<sub>4</sub>"x13"

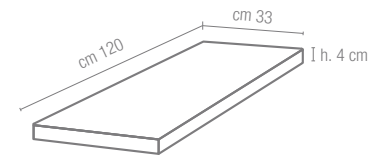

**Bordo - Terminale Gradino Outdoor**

cm 11x90 - 4<sup>3</sup>/<sub>8</sub>"x35<sup>3</sup>/<sub>8</sub>"  
cm 15x120 - 5<sup>7</sup>/<sub>8</sub>"x47<sup>1</sup>/<sub>4</sub>"

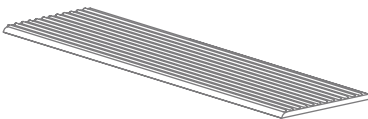

**Art. 9660 Pool Wave**  
cm 60x25 - 23<sup>5</sup>/<sub>8</sub>"x9<sup>7</sup>/<sub>8</sub>"

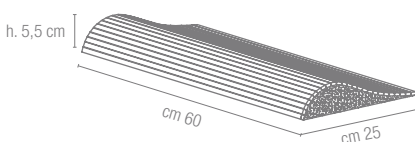

**Art. 9667 Pool Wave**  
cm 25x29 - 9<sup>7</sup>/<sub>8</sub>"x11<sup>1</sup>/<sub>2</sub>"

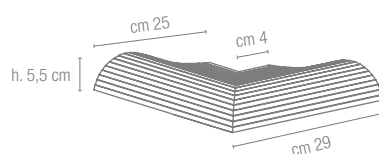

**Art. 9668 Pool Wave**  
cm 25x29 - 9<sup>7</sup>/<sub>8</sub>"x11<sup>1</sup>/<sub>2</sub>"

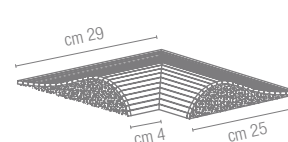

SUPERFICI SURFACES SURFACES OBERFLÄCHEN

**newood**

GRANITOKER

**naturale matt naturelle matt**  
**R10 A+B**

**outdoor R11 A+B+C**





# metalwood

GRANITOKER



**argento, carbonio** cm 20x120 - 7<sup>7</sup>/<sub>8</sub>"x47<sup>1</sup>/<sub>4</sub>", cm 15x120 - 5<sup>7</sup>/<sub>8</sub>"x47<sup>1</sup>/<sub>4</sub>", cm 45x90 - 17<sup>3</sup>/<sub>4</sub>"x45<sup>3</sup>/<sub>8</sub>"

## COLORI COLOURS COULEURS FARBEN

carbonio



silicio



piombo



argento



iridio



# metalwood

GRANITOKER

platino



piombo cm 30x60 - 11<sup>3</sup>/<sub>4</sub>"x23<sup>5</sup>/<sub>8</sub>"

## FORMATI SIZES FORMATS FORMATE

Formati Sizes Formats Formate	<b>cm 10x60</b> 4"x23 <sup>5</sup> / <sub>8</sub> "	<b>cm 30x60</b> 11 <sup>3</sup> / <sub>4</sub> "x23 <sup>5</sup> / <sub>8</sub> "	<b>cm 60x60</b> 23 <sup>5</sup> / <sub>8</sub> "x23 <sup>5</sup> / <sub>8</sub> "	<b>cm 15x90</b> 5 <sup>7</sup> / <sub>8</sub> "x35 <sup>3</sup> / <sub>8</sub> "	<b>cm 45x90</b> 17 <sup>3</sup> / <sub>4</sub> "x35 <sup>3</sup> / <sub>8</sub> "	<b>cm 15x120</b> 5 <sup>7</sup> / <sub>8</sub> "x47 <sup>1</sup> / <sub>4</sub> "	<b>cm 20x120</b> 7 <sup>7</sup> / <sub>8</sub> "x47 <sup>1</sup> / <sub>4</sub> "	<b>cm 60x120</b> 23 <sup>5</sup> / <sub>8</sub> "x47 <sup>1</sup> / <sub>4</sub> "
Superfici Surfaces Surfaces Oberflächen	●	●	●	●	●	●	●	●
	mm 9	mm 9	mm 10	mm 10	mm 10	mm 10	mm 10	mm 10



● Naturale Matt Naturelle Matt **R9 A**

Vedi pagina: See page: Voir page : Siehe Seite: **448**

Rettificate in un unico calibro Rectified version in a single caliber Rectifiés en un unique calibre Boden Sie in einem einzigen Kaliber

Nel caso di combinazioni di formati di spessori diversi, specificarlo espressamente nell'ordine

Please specify in your order if you wish to purchase formats including more than one thickness

Prrière de spécifier dans votre commande si vous souhaitez acheter des formats avec différentes épaisseurs

Bitte weisen Sie im Bestellungsformular ausdrücklich darauf hin, wenn Sie Formatkombinationen mit verschiedenen Stärken wünschen

Caratteristiche tecniche e imballi a pagina: Technical features and packing on page: Caractéristiques techniques et emballages à la page: Technische Eigenschaften und Verpackungen auf Seite: **440**

## PEZZI SPECIALI TRIMS ACCESSOIRES FORMSTÜCKE

**Battiscopa Bullnose**  
**Plinthe à bord arrondi**  
**Stehsockel**  
cm 9x60 - 3<sup>1</sup>/<sub>2</sub>"x23<sup>5</sup>/<sub>8</sub>"  
cm 9x90 - 3<sup>1</sup>/<sub>2</sub>"x35<sup>3</sup>/<sub>8</sub>"



**Gradino Step tread**  
**Nez de marche Stufenplatte**  
cm 30x60 - 11<sup>3</sup>/<sub>4</sub>"x23<sup>5</sup>/<sub>8</sub>"  
cm 30x120 - 11<sup>3</sup>/<sub>4</sub>"x47<sup>1</sup>/<sub>4</sub>"

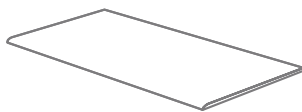

**Tozzetto Insert**  
**Caboçon Einleger**  
cm 10x10 - 4"x4"



**Gradone (assemblato)\***  
cm 60x33 - 23<sup>5</sup>/<sub>8</sub>"x13"  
cm 120x33 - 47<sup>1</sup>/<sub>4</sub>"x13"

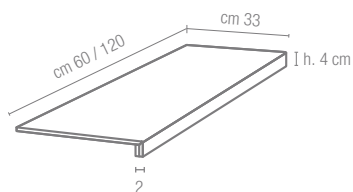

**Angolare (assemblato)\***  
cm 60x33 - 23<sup>5</sup>/<sub>8</sub>"x13"  
cm 120x33 - 47<sup>1</sup>/<sub>4</sub>"x13"

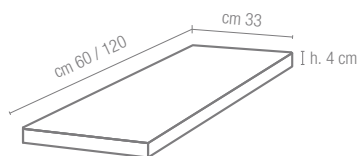

\* Disponibile nei colori Available in the colours Disponible dans les couleurs Verfügbar in den folgenden Farben: **Platino, Iridio, Argento, Piombo.**

Altri colori sono prodotti solo su richiesta. Other colours are produced on demand only. Autres teintes disponibles sur demand. Andere Farben nur auf Anfrage.

## DECORI DECORS DÉCORS DEKORE

## metalwood

GRANITOKER

mix listelli metalwood A



**cm 30x30 - 11<sup>3</sup>/<sub>4</sub>"x11<sup>3</sup>/<sub>4</sub>"**  
 listello **cm 1,4x30 - 1/2"x11<sup>3</sup>/<sub>4</sub>"**  
*su rete on net sur trame auf Netz*  
 silicio, piombo, argento

mix listelli metalwood C



**cm 30x30 - 11<sup>3</sup>/<sub>4</sub>"x11<sup>3</sup>/<sub>4</sub>"**  
 listello **cm 1,4x30 - 1/2"x11<sup>3</sup>/<sub>4</sub>"**  
*su rete on net sur trame auf Netz*  
 argento, piombo, platino

mosaico 6x6\*



**cm 30x30 - 11<sup>3</sup>/<sub>4</sub>"x11<sup>3</sup>/<sub>4</sub>"**  
 tessera **cm 6x6 - 2<sup>3</sup>/<sub>8</sub>"x2<sup>3</sup>/<sub>8</sub>"**  
*su rete on net sur trame auf Netz*

fascia metalwood\*



**cm 10x60 - 4"x23<sup>5</sup>/<sub>8</sub>"**

\* Disponibile in tutti i colori della serie Available in all the colours of the series  
 Disponible dans tous les couleurs de la série Verfügbar in allen Farben



argento cm 10x60 - 4"x23<sup>5</sup>/<sub>8</sub>", carbonio cm 10x60 - 4"x23<sup>5</sup>/<sub>8</sub>"

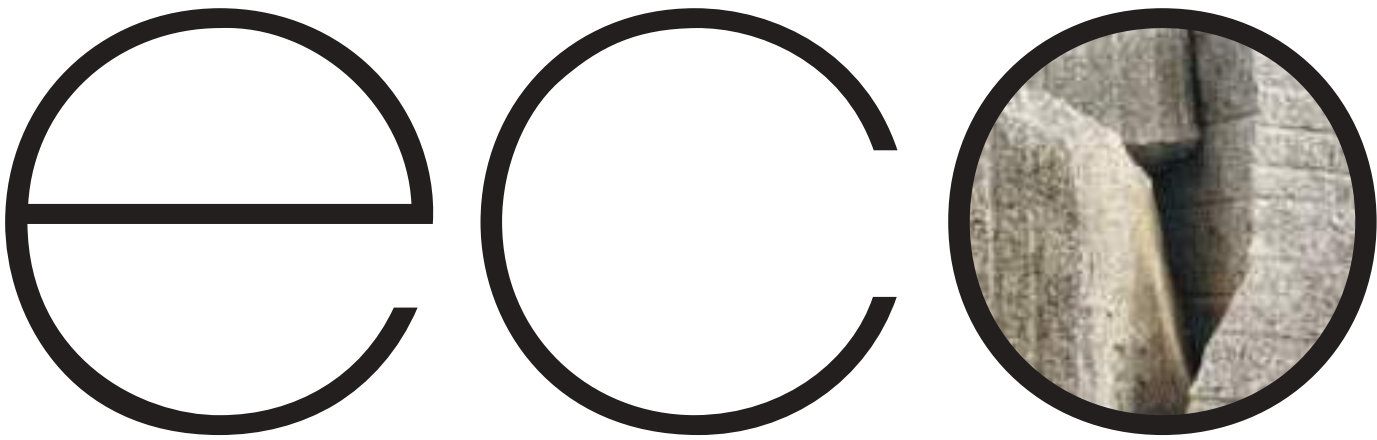

eco**granite** éco**granit** öko**granit**

**granito**

# eco**granito**

280 **granito evo**

284 **granito 1**

290 **granito 2**

294 **granito 3**



**GRANITO**

Roccia fanero cristallina da costruzione e decorazione, compatta e lucidabile, prevalentemente costituita da minerali di durezza Mohs da 6 a 7, come i quarzi, i feldspati e i feldspatoidi. In funzione della loro composizione possono essere distinti: i graniti propriamente detti [rocce magmatiche intrusive acide fanero-cristalline, costituite da quarzo, feldspati sodico potassici e miche]; altre rocce magmatiche intrusive (dioriti, granodioriti, sieniti, gabbri eccetera); rocce magmatiche effusive a struttura porfirica; alcune rocce metamorfiche di analoga composizione come gneiss e serizzi.

**GRANITE**

Crystalline phaneritic rock for decorative and building purposes. It is compact, can be polished and mainly consists of minerals with 6 to 7 Mohs hardness such as quartzes, feldspars and feldspathoids. Depending on their composition, granites include: granite in the strict sense of the term [phaneritic-crystalline intrusive magmatic acid rocks consisting of quartz, soda potash feldspars and micas]; other intrusive magmatic rocks (diorites, granodiorites, syenites, gabbros, etc); magmatic effusive rock with a porphyritic structure; certain metamorphic rocks of similar composition, such as gneiss and paragneiss.





# granito evo

GRANITOGRES



denver cm 30x30 - 11<sup>3</sup>/<sub>4</sub>"x11<sup>3</sup>/<sub>4</sub>"

## COLORI COLOURS COULEURS FARBEN

new york

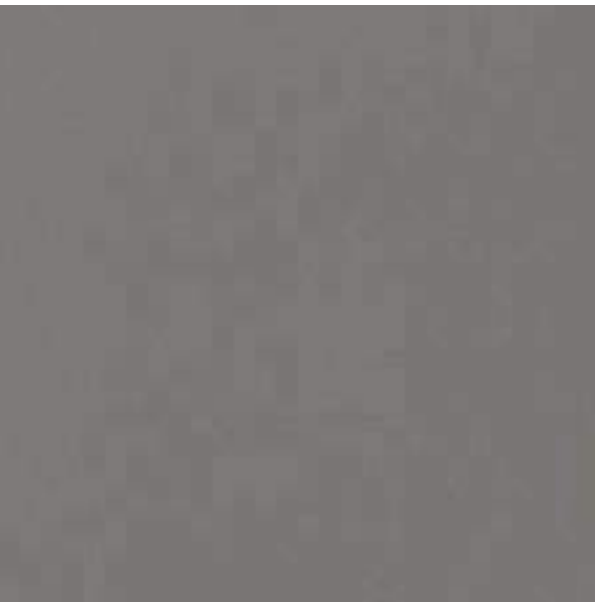

chicago



denver



seattle



tucson







boston

## FORMATI SIZES FORMATS FORMATE

# granito evo

GRANITOGRES

				
<b>Formati Sizes</b> <b>Formats Formate</b>	<b>cm 30x30</b> 11 <sup>3</sup> / <sub>4</sub> "x11 <sup>3</sup> / <sub>4</sub> "	<b>cm 45x45</b> 17 <sup>3</sup> / <sub>4</sub> "x17 <sup>3</sup> / <sub>4</sub> "	<b>cm 30x60</b> 11 <sup>3</sup> / <sub>4</sub> "x23 <sup>5</sup> / <sub>8</sub> "	<b>cm 60x60*</b> 23 <sup>5</sup> / <sub>8</sub> "x23 <sup>5</sup> / <sub>8</sub> "
<b>Superfici Surfaces</b> <b>Surfaces Oberflächen</b>	● ●	●	●	● ●
	mm 7,6	mm 9	mm 9	mm 10 mm 14**



Uniforme  
Uniform  
Uniforme  
Einheitliche

Vedi pagina: See page: Voir page : Siehe Seite: **448**

- Naturale Matt Naturelle Matt **R10 A**
- Secura **R11 A+B**
- Levigata Polished Polie Poliert

\* Rettificate in un unico calibro Rectified version in a single caliber Rectifiés en un unique calibre Boden Sie in einem einzigen Kaliber

\*\* Solo nei colori: Only in the colours: Seulement dans les couleurs : Nur in die Farben: **Boston, Denver, Seattle**  
Solo Naturale Matt only Seulement Naturelle Nur Matt

Caratteristiche tecniche e imballi a pagina: Technical features and packing on page: Caractéristiques techniques et emballages à la page: Technische Eigenschaften und Verpackungen auf Seite: **434**

## PEZZI SPECIALI TRIMS ACCESSOIRES FORMSTÜCKE

**Battiscopa Bullnose**  
**Plinthe à bord arrondi**  
**Stehsockel**

**cm 9x30** - 3<sup>1</sup>/<sub>2</sub>"x11<sup>3</sup>/<sub>4</sub>"  
**cm 9x45** - 3<sup>1</sup>/<sub>2</sub>"x17<sup>3</sup>/<sub>4</sub>"  
**cm 9x60** - 3<sup>1</sup>/<sub>2</sub>"x 23<sup>5</sup>/<sub>8</sub>"



**Zoccolo a raccordo a taglio retto**  
**Cove base - straight top**  
**Plinthe à gorge avec bord vif**  
**Hohlkehlsocbel (scharfkantig)**  
**cm 10x30** - 4"x11<sup>3</sup>/<sub>4</sub>"

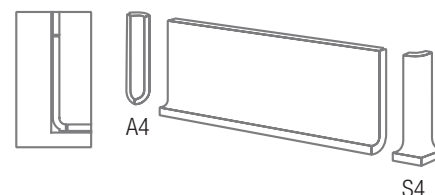

**Gradino Step tread**  
**Nez de marche Stufenplatte**  
**cm 30x30** - 11<sup>3</sup>/<sub>4</sub>"x11<sup>3</sup>/<sub>4</sub>"

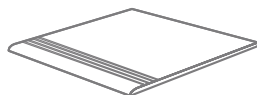

**Zoccolo ad appoggio smussato**  
**Sit-on skirting - bevelled top**  
**Plinthe à talon avec bord arrondi**  
**Aufsetzsockel mit abgerundeter Kante**  
**cm 10x30** - 4"x11<sup>3</sup>/<sub>4</sub>"

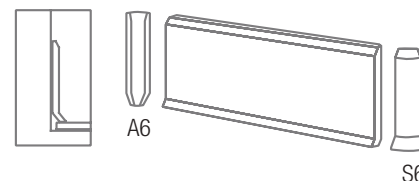



# granito 1

GRANITOGRES



nebraska cm 30x60 - 11<sup>3</sup>/<sub>4</sub>"x23<sup>5</sup>/<sub>8</sub>"

## COLORI COLOURS COULEURS FARBEN

dakota



ontario



giamaica



arkansas



arizona



everest



# granito 1

GRANITOGRES

georgia



labrador



nebraska

nevada

## COLORI COLOURS COULEURS FARBEN

iberia

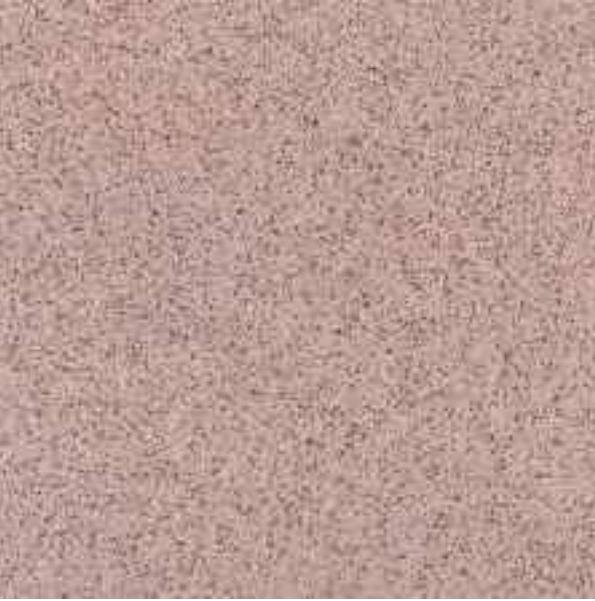





sahara



colorado

## FORMATI SIZES FORMATS FORMATE

				
Formati Sizes Formats Formate	<b>cm 20x20</b> 7 <sup>7</sup> / <sub>8</sub> "x7 <sup>7</sup> / <sub>8</sub> "	<b>cm M 12,5x25**</b> 4 <sup>7</sup> / <sub>8</sub> "x9 <sup>7</sup> / <sub>8</sub> "	<b>cm 30x30</b> 11 <sup>3</sup> / <sub>4</sub> "x11 <sup>3</sup> / <sub>4</sub> "	<b>cm 40x40</b> 15 <sup>3</sup> / <sub>4</sub> "x15 <sup>3</sup> / <sub>4</sub> "
Arizona	●		● ●	
Arkansas	● ●	●	● ● ●	● ●
Colorado	●		● ●	
Dakota	●		● ●	
Everest	●		● ●	
Georgia	●		● ●	
Giamaica			● ●	
Iberia			● ●	
Labrador	●		● ●	
Nebraska	● ●		● ● ●	● ●
Nevada			● ●	
Ontario	● ●		● ● ●	● ●
Sahara	●	●	● ●	● ●
	mm 8	mm 8	mm 8	mm 9



Uniforme  
Uniform  
Uniforme  
Einheitliche

Vedi pagina: See page: Voir page : Siehe Seite: **448**

- Naturale Matt Naturelle Matt **R9 A**
- Levigata Polished Polie Poliert
- Technic **R10**

\* Spessore su superficie naturale Thickness on matt surface Épaisseur sur surface naturelle Stärke der Fliesen mit Mattoberfläche

\*\* Misure di fabbricazione: Worksizes: Cotes de fabrication: Herstellmasse: **cm 11,8x24,3**

Per superfici speciali antiscivolo e spessori maggiorati vedere collezione Technic a pag: For increased thicknesses and special no-slip surfaces see the Technic collection on page:

Pour des surfaces antidérapantes et les épaisseurs majorés, voir collection Technic à la page: Für sonderdrehgeschmiedene Oberflächen und Stärken siehe Kollektion Technic auf Seite: **416**

Caratteristiche tecniche e imballi a pagina: Technical features and packing on page: Caractéristiques techniques et emballages à la page: Technische Eigenschaften und Verpackungen auf Seite: **434**

## PEZZI SPECIALI TRIMS ACCESSOIRES FORMSTÜCKE

**Battiscopa Bullnose**  
**Plinthe à bord arrondi**  
**Stehsokkel**  
cm 9x30 - 3<sup>1</sup>/<sub>2</sub>"x11<sup>3</sup>/<sub>4</sub>"  
cm 9x40 - 3<sup>1</sup>/<sub>2</sub>"x15<sup>3</sup>/<sub>4</sub>"  
cm 10x20 - 4"x7<sup>7</sup>/<sub>8</sub>"

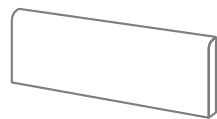

**Zoccolo a raccordo a taglio retto\***  
**Cove base - straight top\***  
**Plinthe à gorge avec bord vif\***  
**Hohlkehlsokkel (scharfkantig)\***  
cm 10x20 - 4"x7<sup>7</sup>/<sub>8</sub>"

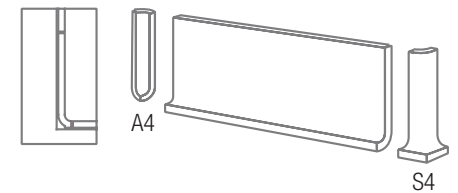

**Gradino Step tread**  
**Nez de marche Stufenplatte**  
cm 30x30 - 11<sup>3</sup>/<sub>4</sub>"x11<sup>3</sup>/<sub>4</sub>"

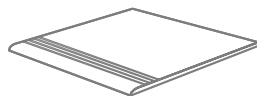

**Zoccolo ad appoggio smussato\***  
**Sit-on skirting - bevelled top\***  
**Plinthe à talon avec bord arrondi\***  
**Aufsetzsockel mit abgerundeter Kante\***  
cm 10x20 - 4"x7<sup>7</sup>/<sub>8</sub>"

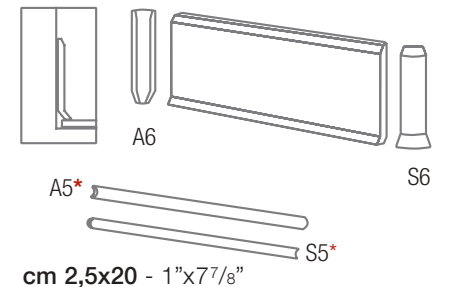

**Listello Listel**  
**Listel Zeierleiste**  
cm 9x30 - 3<sup>1</sup>/<sub>2</sub>"x11<sup>3</sup>/<sub>4</sub>"  
cm 9x40 - 3<sup>1</sup>/<sub>2</sub>"x15<sup>3</sup>/<sub>4</sub>"



**Sguscetta\* Cove\***  
**Gorge\* Rinnleiste\***  
cm 4x20 - 1<sup>5</sup>/<sub>8</sub>"x7<sup>7</sup>/<sub>8</sub>"

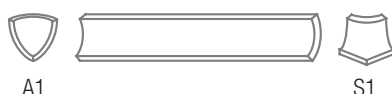

**Tozzetto Insert**  
**Cabochon Einleger**  
cm 9x9 - 3<sup>1</sup>/<sub>2</sub>"x 3<sup>1</sup>/<sub>2</sub>"



\* Produzione corrente solo nei colori: Currently produced only in the following colours: Productions courantes seulement dans les couleurs: Aktuelle Produktion nur in den Farben:

**Arkansas, Nebraska, Ontario**

Altri colori sono prodotti su richiesta Other colours are produced on demand Autres teintes disponibles sur demand Andere Farben nur auf Antrag



# granito 2

GRANITOGRES



milano, tactile cm 30x30 - 11<sup>3</sup>/<sub>4</sub>"x11<sup>3</sup>/<sub>4</sub>"

## COLORI COLOURS COULEURS FARBEN

milano



cortina

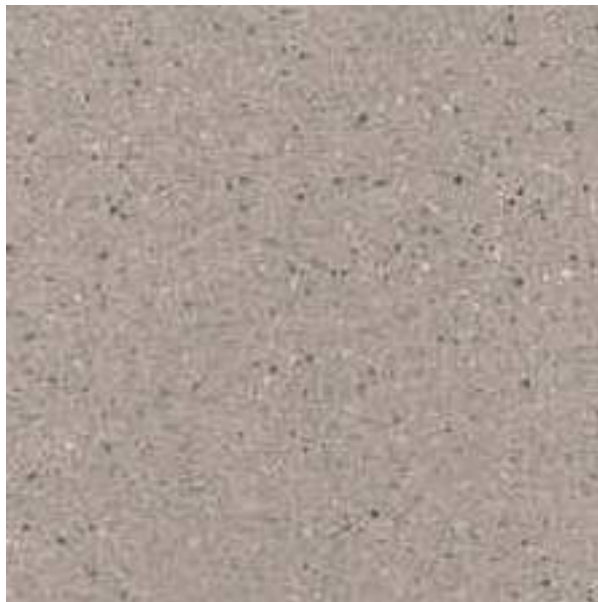

cervinia



siena



gallipoli



amalfi

## FORMATI SIZES FORMATS FORMATE



Formati Sizes  
Formats Formate

**cm 30x30**  
11<sup>3</sup>/<sub>4</sub>"x11<sup>3</sup>/<sub>4</sub>"

Superfici Surfaces  
Surfaces Oberflächen



mm 8,3



Uniforme  
Uniform  
Uniforme  
Einheitliche

● Naturale Matt Naturelle Matt **R10 A**

Vedi pagina: See page: Voir page : Siehe Seite: **448**

Caratteristiche tecniche e imballi a pagina: Technical features and packing on page:  
Caractéristiques techniques et emballages à la page: Technische Eigenschaften und  
Verpackungen auf Seite: **434**

## PEZZI SPECIALI TRIMS ACCESSOIRES FORMSTÜCKE

**Battiscopa Bullnose**  
**Plinthe à bord arrondi**  
**Stehsockel**  
cm 9x30 - 3<sup>1</sup>/<sub>2</sub>"x11<sup>3</sup>/<sub>4</sub>"

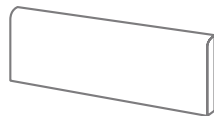

**Gradino Step tread**  
**Nez de marche Stufenplatte**  
cm 30x30 - 11<sup>3</sup>/<sub>4</sub>"x11<sup>3</sup>/<sub>4</sub>"

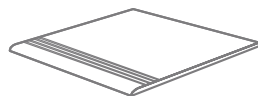

SUPERFICI  
SURFACES  
SURFACES  
OBERFLÄCHEN

# granito 2

GRANITOGRES

levigata polished  
polie poliert

naturale matt  
naturelle matt  
R10 A





# granito 3

GRANITOGRES



casablanca, tokyo, montreal cm 30x30 - 11<sup>3</sup>/<sub>4</sub>"x11<sup>3</sup>/<sub>4</sub>"

## COLORI COLOURS COULEURS FARBEN

budapest



montreal



shanghai



ajaccio



tokyo



casablanca

## FORMATI SIZES FORMATS FORMATE



Formati Sizes  
Formats Formate

**cm 30x30**  
11<sup>3</sup>/<sub>4</sub>"x11<sup>3</sup>/<sub>4</sub>"

Superfici Surfaces  
Surfaces Oberflächen



mm 8,3



Uniforme  
Uniform  
Uniforme  
Einheitliche

● Naturale Matt Naturelle Matt **R10 A**

Vedi pagina: See page: Voir page : Siehe Seite: **448**

Caratteristiche tecniche e imballi a pagina: Technical features and packing on page:  
Caractéristiques techniques et emballages à la page: Technische Eigenschaften und  
Verpackungen auf Seite: **434**

## PEZZI SPECIALI TRIMS ACCESSOIRES FORMSTÜCKE

**Battiscopa Bullnose**  
**Plinthe à bord arrondi**  
**Stehsockel**  
cm 9x30 - 3<sup>1</sup>/<sub>2</sub>"x11<sup>3</sup>/<sub>4</sub>"

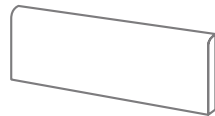

**Gradino Step tread**  
**Nez de marche Stufenplatte**  
cm 30x30 - 11<sup>3</sup>/<sub>4</sub>"x11<sup>3</sup>/<sub>4</sub>"

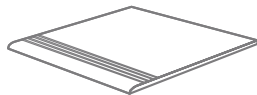

SUPERFICI  
SURFACES  
SURFACES  
OBERFLÄCHEN

# granito 3

GRANITOGRES

levigata polished  
polie poliirt

naturale matt  
naturelle matt  
R10 A

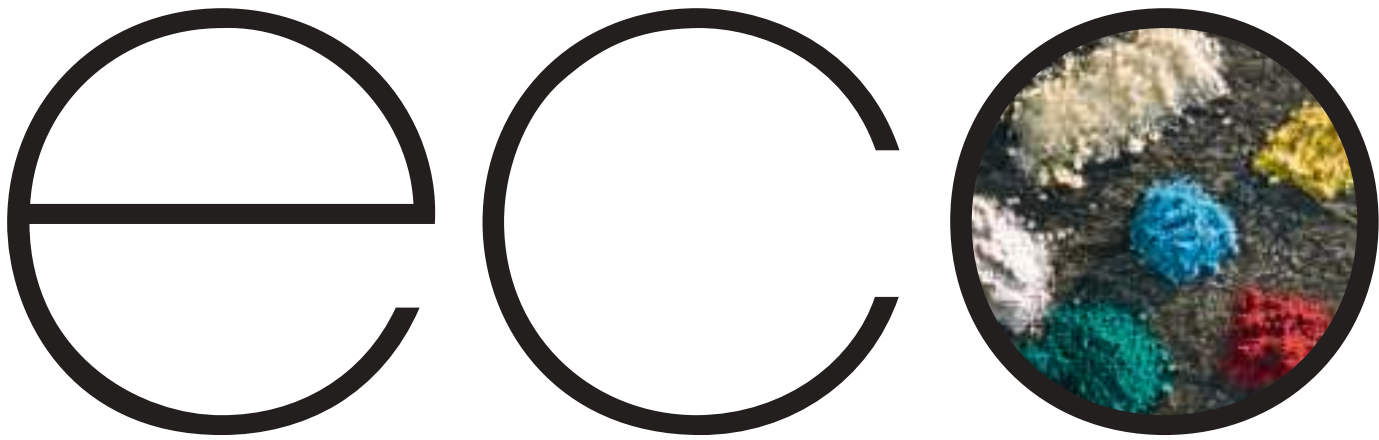

eco**colour** éco**couleur** öko**farbe**

**colore**

# eco**colore**

- 302 **earth**
- 310 **architecture**
- 322 **unicolore**
- 328 **caleidoscopio**
- 334 **elementi**
- 338 **landscape**







# earth by pininfarina

GRANITOKER



earth grigio 4, earth grigio 1 cm 60x120 - 23<sup>5</sup>/<sub>8</sub>"x47<sup>1</sup>/<sub>4</sub>", 30x120 - 11<sup>3</sup>/<sub>4</sub>"x47<sup>1</sup>/<sub>4</sub>, 15x120 - 5<sup>7</sup>/<sub>8</sub>"x47<sup>1</sup>/<sub>4</sub>"

## COLORI COLOURS COULEURS FARBEN

earth blu



earth grigio 4

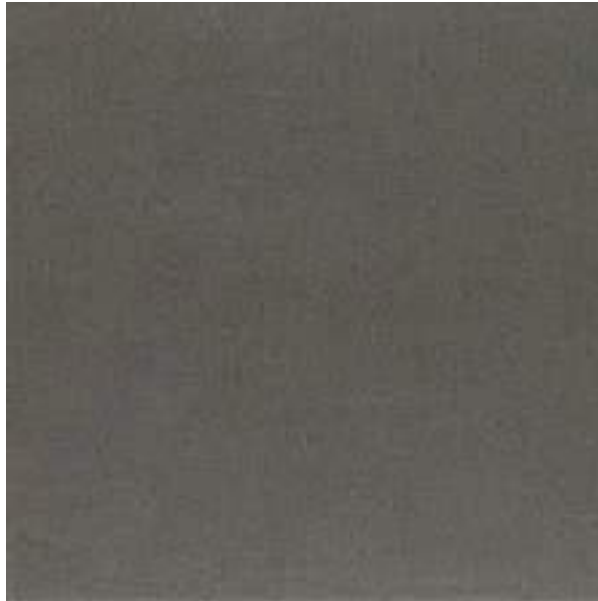

earth grigio 3



earth brunello



earth metalred



earth tortora 1

# earth by pininfarina

GRANITOKER

earth grigio 2





earth grigio 1



earth bianco

## FORMATI SIZES FORMATS FORMATE

Formati Sizes Formats Formate	<b>cm 30x60</b> 11 <sup>3</sup> / <sub>4</sub> "x23 <sup>5</sup> / <sub>8</sub> "	<b>cm 60x60</b> 23 <sup>5</sup> / <sub>8</sub> "x23 <sup>5</sup> / <sub>8</sub> "	<b>cm 15x120</b> 5 <sup>7</sup> / <sub>8</sub> "x47 <sup>1</sup> / <sub>4</sub> "	<b>cm 30x120</b> 11 <sup>3</sup> / <sub>4</sub> "x47 <sup>1</sup> / <sub>4</sub> "	<b>cm 60x120</b> 23 <sup>5</sup> / <sub>8</sub> "x47 <sup>1</sup> / <sub>4</sub> "
Superfici Surfaces Surfaces Oberflächen	●	●	●	●	●
	mm 10	mm 10	mm 10	mm 10	mm 10
 Media Medium Modérée Mittlere					● Naturale Matt Naturelle Matt <b>R10</b>

Vedi pagina: See page: Voir page : Siehe Seite: **448**

Rettificate in un unico calibro Rectified version in a single caliber Rectifiés en un unique calibre Boden Sie in einem einzigen Kaliber

Caratteristiche tecniche e imballi a pagina: Technical features and packing on page: Caractéristiques techniques et emballages à la page: Technische Eigenschaften und Verpackungen auf Seite: **440**

## PEZZI SPECIALI TRIMS ACCESSOIRES FORMSTÜCKE

**Battiscopa Bullnose**  
**Plinthe à bord arrondi**  
**Stehsokkel**  
cm 9x60 - 3<sup>1</sup>/<sub>2</sub>"x23<sup>5</sup>/<sub>8</sub>"



**Terminale Chrome/Silver**  
cm 1x60 - <sup>3</sup>/<sub>8</sub>"x23<sup>5</sup>/<sub>8</sub>"



**Spigolo listello**  
**Chrome/Silver**  
cm 1x3,6 - <sup>3</sup>/<sub>8</sub>"x1<sup>3</sup>/<sub>8</sub>"



**Spigolo terminale**  
**Chrome/Silver**  
cm 1x1 - <sup>3</sup>/<sub>8</sub>"x<sup>3</sup>/<sub>8</sub>"



**Gradone (assemblato)**  
cm 60x33 - 23<sup>5</sup>/<sub>8</sub>"x13"

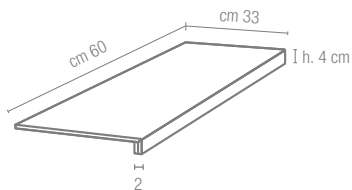

**Angolare (assemblato)**  
cm 60x33 - 23<sup>5</sup>/<sub>8</sub>"x13"

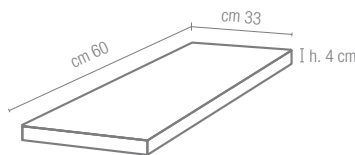

**Gradino Step tread**  
**Nez de marche Stufenplatte**  
cm 30x60 - 11<sup>3</sup>/<sub>4</sub>"x23<sup>5</sup>/<sub>8</sub>"  
cm 30x120 - 11<sup>3</sup>/<sub>4</sub>"x47<sup>1</sup>/<sub>4</sub>"

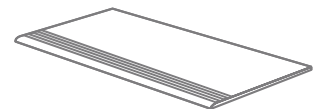

## LOGO

Piastrella con firma in acciaio.  
Disponibile in tutti i formati  
e colori della collezione.

Tile with steel signature.  
Available in all the sizes  
of the collection.

Dalle avec signature en acier.  
Disponibile dans tous  
les formats et dans toutes  
les couleurs de la collection.

Fliese mit Signatur aus Stahl.  
Verfügbar in allen Farben  
und Formaten der Kollektion.

# earth by pininfarina

GRANITOKER

*pininfarina*

*pininfarina*

## DECORI DECORS DÉCORS DEKORE

## line\*



cm 30x60 - 11<sup>3</sup>/<sub>4</sub>"x23<sup>5</sup>/<sub>8</sub>"  
cm 15x120 - 5<sup>7</sup>/<sub>8</sub>"x47<sup>1</sup>/<sub>4</sub>"

## varnish

## listello mirror silver\*



cm 3,6x120 - 1<sup>3</sup>/<sub>8</sub>"x47<sup>1</sup>/<sub>4</sub>"

## listello blu chrome\*\*



cm 3,6x120 - 1<sup>3</sup>/<sub>8</sub>"x47<sup>1</sup>/<sub>4</sub>"

## listello red chrome\*\*



cm 3,6x120 - 1<sup>3</sup>/<sub>8</sub>"x47<sup>1</sup>/<sub>4</sub>"

\* Piastrella con inserto bacchetta argento.  
Disponibile in tutti i colori della serie  
Tile with a silver border strip.  
Available in all the colours of the series  
Dalle avec insert pour baguette argent.  
Disponibile dans toutes les couleurs de la série  
Fliese mit Zierleisteneinsatz aus Silber.  
Verfügbar in allen Farben

\* Cromato Chrome-plated Chromé Chrom

\*\* In vernice micallizzata Made of 'mica' varnish  
En 'mica' peinture Aus 'mica' Anstrich

Listello Logo con firma Pininfarina (un pezzo per scatola)  
With Pininfarina signature (one piece per box)  
Avec signature Pininfarina (une pièce pour boîte)  
Mit Signatur Pininfarina (ein Stück pro Karton)

listello mirror silver,  
line, earth bianco, earth blu  
cm 15x120 - 5<sup>7</sup>/<sub>8</sub>"x47<sup>1</sup>/<sub>4</sub>"  
30x120 - 11<sup>3</sup>/<sub>4</sub>"x47<sup>1</sup>/<sub>4</sub>"  
60x120 - 23<sup>5</sup>/<sub>8</sub>"x47<sup>1</sup>/<sub>4</sub>"  
3,6x120 - 1<sup>3</sup>/<sub>8</sub>"x47<sup>1</sup>/<sub>4</sub>"

listello mirror silver, line, earth blu  
cm 15x120 - 5<sup>7</sup>/<sub>8</sub>"x47<sup>1</sup>/<sub>4</sub>"  
30x120 - 11<sup>3</sup>/<sub>4</sub>"x47<sup>1</sup>/<sub>4</sub>"  
60x120 - 23<sup>5</sup>/<sub>8</sub>"x47<sup>1</sup>/<sub>4</sub>"  
3,6x120 - 1<sup>3</sup>/<sub>8</sub>"x47<sup>1</sup>/<sub>4</sub>"

# earth by pininfarina

GRANITOKER

## wood

**listello radica silver\***



cm 3,6x120 - 1<sup>3</sup>/<sub>8</sub>"x47<sup>1</sup>/<sub>4</sub>"

**listello palissandro silver\***



cm 3,6x120 - 1<sup>3</sup>/<sub>8</sub>"x47<sup>1</sup>/<sub>4</sub>"

**listello daniela silver\***



cm 3,6x120 - 1<sup>3</sup>/<sub>8</sub>"x47<sup>1</sup>/<sub>4</sub>"

\* In legno naturale Made of real wood  
En bois véritable Aus echtem Holz

**Listello Logo** con firma Pininfarina (un pezzo per scatola)  
With **Pininfarina signature** (one piece per box)  
Avec signature Pininfarina (une pièce pour boîte)  
Mit **Signatur Pininfarina** (ein Stück pro Karton)

## leather

**listello nubia chrome\***



cm 3,6x120 - 1<sup>3</sup>/<sub>8</sub>"x47<sup>1</sup>/<sub>4</sub>"

**listello castagna\***



cm 3,6x120 - 1<sup>3</sup>/<sub>8</sub>"x47<sup>1</sup>/<sub>4</sub>"

**listello rojo chrome\***



cm 3,6x120 - 1<sup>3</sup>/<sub>8</sub>"x47<sup>1</sup>/<sub>4</sub>"

\* In vera pelle Made of genuine leather  
En cuir naturel Aus echtem Leder

**Listello Logo** con firma Pininfarina (un pezzo per scatola)  
With **Pininfarina signature** (one piece per box)  
Avec signature Pininfarina (une pièce pour boîte)  
Mit **Signatur Pininfarina** (ein Stück pro Karton)







# architecture

GRANITOGRES



architecture cool grey *matt* cm 90x90 - 35<sup>3</sup>/<sub>8</sub>"x35<sup>3</sup>/<sub>8</sub>"

## COLORI COLOURS COULEURS FARBEN

architecture black matt

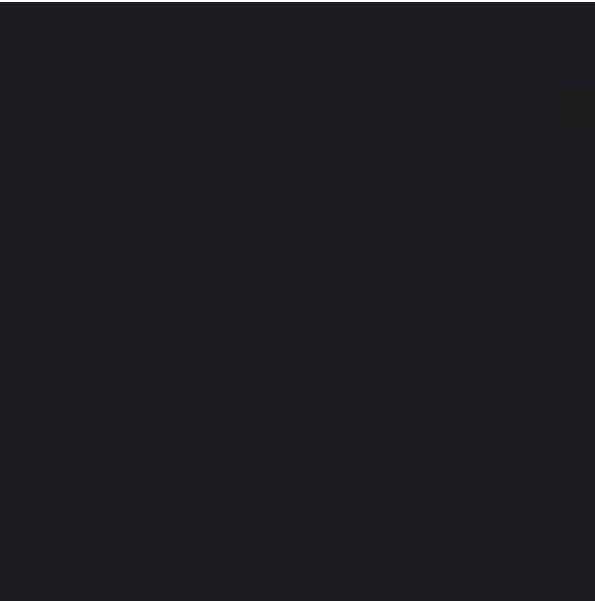

architecture dark grey matt

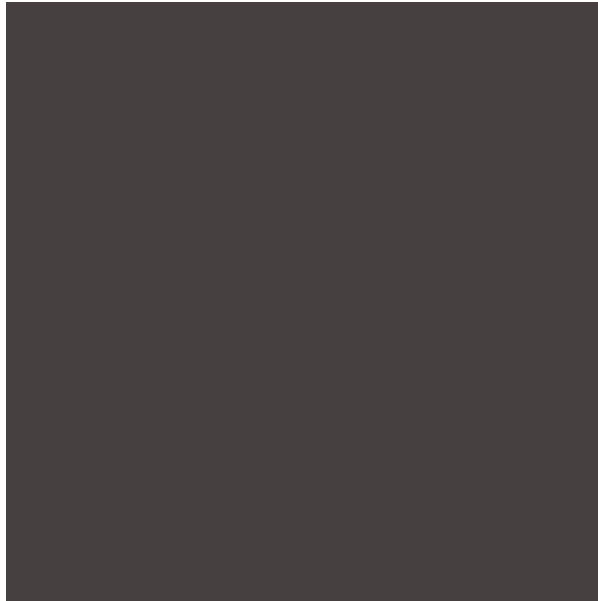

architecture medium grey matt



architecture black gloss



architecture dark grey gloss



architecture medium grey gloss

# architecture

GRANITOGRES

architecture light grey matt



architecture cool grey matt



architecture warm grey matt



architecture light grey gloss

architecture cool grey gloss

architecture warm grey gloss

## COLORI COLOURS COULEURS FARBEN

architecture light brown matt

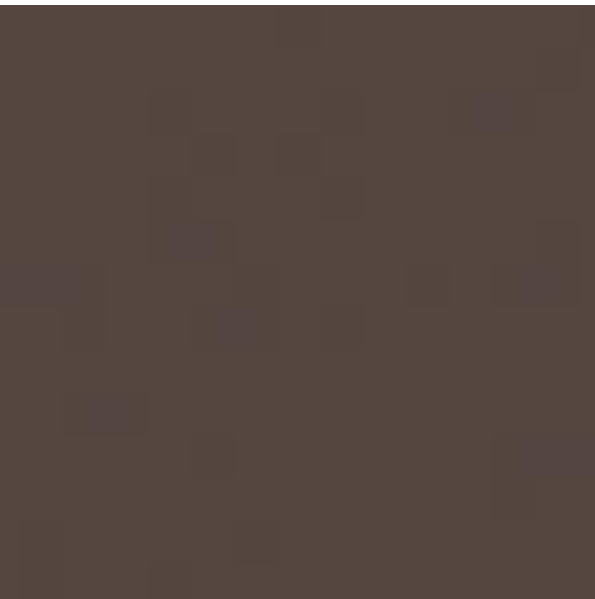

architecture dark ivory matt



architecture light ivory matt

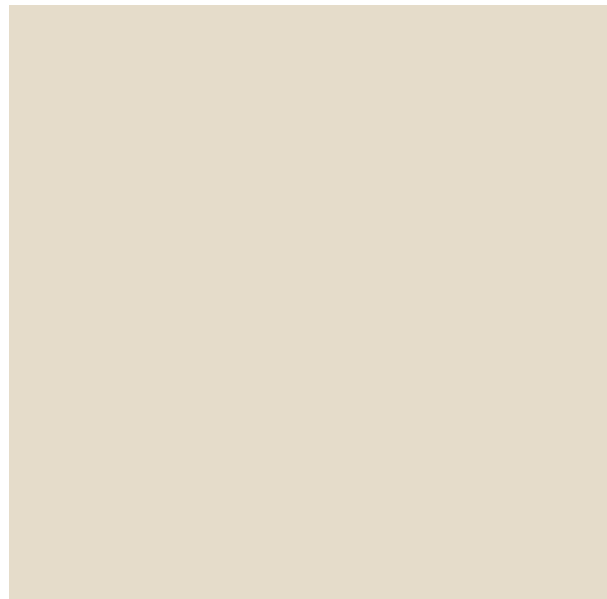

architecture light brown gloss

architecture dark ivory gloss

architecture light ivory gloss

# architecture

GRANITOGRES

architecture beige matt



architecture white matt

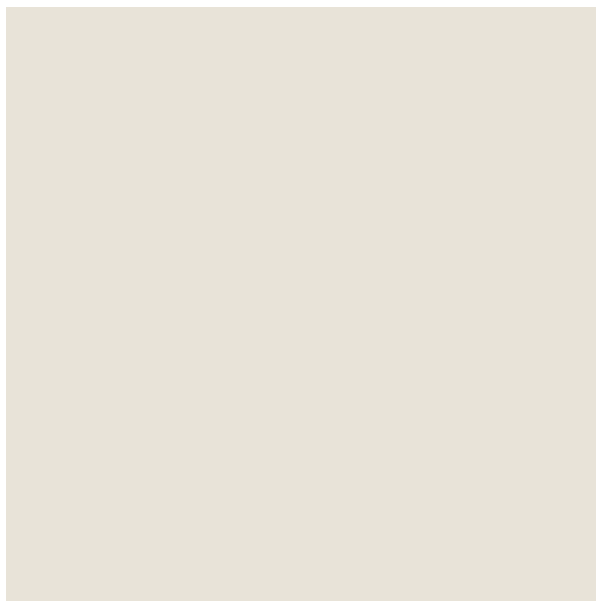

architecture beige gloss

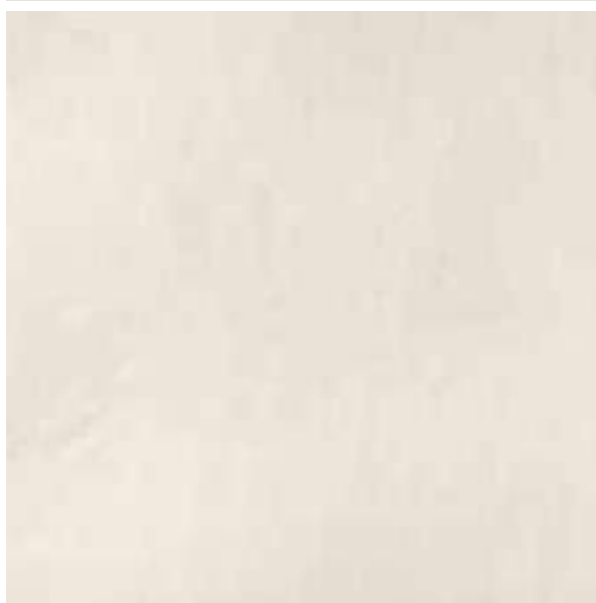

architecture white gloss

## COLORI COLOURS COULEURS FARBEN

**architecture purple matt**



**architecture acid green matt**



**architecture purple gloss**

**architecture acid green gloss**

SUPERFICI SURFACES  
SURFACES OBERFLÄCHEN

**architecture**

GRANITOGRES

levigata polished polie poliirt

naturale matt naturelle matt R9

gloss R9

## FORMATI SIZES FORMATS FORMATE

Formati Sizes Formats Formate	<b>cm 30x30</b> 11 <sup>3</sup> / <sub>4</sub> "x11 <sup>3</sup> / <sub>4</sub> "	<b>cm 15x60</b> 5 <sup>7</sup> / <sub>8</sub> "x23 <sup>5</sup> / <sub>8</sub> "	<b>cm 30x60</b> 11 <sup>3</sup> / <sub>4</sub> "x23 <sup>5</sup> / <sub>8</sub> "	<b>cm 60x60</b> 23 <sup>5</sup> / <sub>8</sub> "x23 <sup>5</sup> / <sub>8</sub> "	<b>cm 15x90*</b> 5 <sup>7</sup> / <sub>8</sub> "x35 <sup>3</sup> / <sub>8</sub> "	<b>cm 45x90*</b> 17 <sup>3</sup> / <sub>4</sub> "x35 <sup>3</sup> / <sub>8</sub> "	<b>cm 90x90*</b> 35 <sup>3</sup> / <sub>8</sub> "x35 <sup>3</sup> / <sub>8</sub> "	<b>cm 60x120</b> 23 <sup>5</sup> / <sub>8</sub> "x47 <sup>1</sup> / <sub>4</sub> "
Superfici Surfaces Surfaces Oberflächen	●	● ●	● ● ●	● ● ●	●	●	●	●
	mm 9,4	mm 9,4	mm 9,4	mm 9,4	mm 10	mm 10	mm 10	mm 9,4



Uniforme  
Uniform  
Uniforme  
Einheitliche

Vedi pagina: See page: Voir page : Siehe Seite: **448**

- Naturale Matt Naturelle Matt **R9**  
(A richiesta On request Sur demand Auf Anfrage **R10**)
- Gloss **R9**
- Levigata Polished Polie Poliert

Rettificate in un unico calibro Rectified version in a single caliber Rectifiés en un unique calibre Boden Sie in einem einzigen Kaliber

\* Ad eccezione di: Except for: À l'exception de: Mit Ausnahme von: **Acid Green, Purple**

Nel caso di combinazioni di formati di spessori diversi, specificarlo espressamente nell'ordine

Please specify in your order if you wish to purchase formats including more than one thickness

Prière de spécifier dans votre commande si vous souhaitez acheter des formats avec différentes épaisseurs

Bitte weisen Sie im Bestellungsformular ausdrücklich darauf hin, wenn Sie Formatkombinationen mit verschiedenen Stärken wünschen

Caratteristiche tecniche e imballi a pagina: Technical features and packing on page: Caractéristiques techniques et emballages à la page: Technische Eigenschaften und Verpackungen auf Seite: **434**

## PEZZI SPECIALI TRIMS ACCESSOIRES FORMSTÜCKE

**Battiscopa Bullnose**  
**Plinthe à bord arrondi**  
**Stehsokkel**  
cm 9x90 - 3<sup>1</sup>/<sub>2</sub>"x35<sup>3</sup>/<sub>8</sub>"  
cm 9x60 - 3<sup>1</sup>/<sub>2</sub>"x23<sup>5</sup>/<sub>8</sub>"



**Gradino Step tread**  
**Nez de marche Stufenplatte**  
cm 30x60 - 11<sup>3</sup>/<sub>4</sub>"x23<sup>5</sup>/<sub>8</sub>"  
cm 30x120 - 11<sup>3</sup>/<sub>4</sub>"x47<sup>1</sup>/<sub>4</sub>"

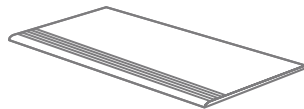

**Gradone (assemblato)**  
cm 60x33 - 23<sup>5</sup>/<sub>8</sub>"x13"

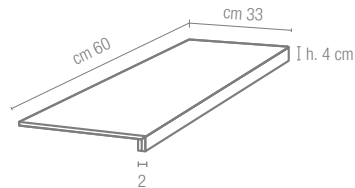

**Angolare (assemblato)**  
cm 60x33 - 23<sup>5</sup>/<sub>8</sub>"x13"

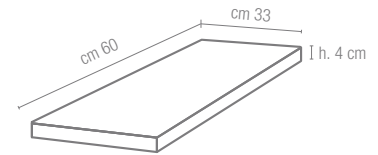

**architecture white,**  
**architecture black**  
cm 30x60 - 11<sup>3</sup>/<sub>4</sub>"x23<sup>5</sup>/<sub>8</sub>"





DECORI DECORS DÉCORS DEKORE

# architecture

GRANITOGRES

**mix listelli  
architecture A**



**cm 30x30 - 11<sup>3</sup>/<sub>4</sub>"x11<sup>3</sup>/<sub>4</sub>"**  
listello **cm 1,4x30 - 1/2"x11<sup>3</sup>/<sub>4</sub>"**  
*su rete on net sur trame auf Netz*  
**beige, dark ivory, light  
ivory, white**  
naturale matt naturelle matt

**mix listelli  
architecture B**



**cm 30x30 - 11<sup>3</sup>/<sub>4</sub>"x11<sup>3</sup>/<sub>4</sub>"**  
listello **cm 1,4x30 - 1/2"x11<sup>3</sup>/<sub>4</sub>"**  
*su rete on net sur trame auf Netz*  
**medium grey, dark grey,  
black**  
naturale matt naturelle matt

**mix listelli  
architecture C**



**cm 30x30 - 11<sup>3</sup>/<sub>4</sub>"x11<sup>3</sup>/<sub>4</sub>"**  
listello **cm 1,4x30 - 1/2"x11<sup>3</sup>/<sub>4</sub>"**  
*su rete on net sur trame auf Netz*  
**warm grey, cool grey,  
light grey, medium grey**  
naturale matt naturelle matt

**mix listelli  
architecture D**



**cm 30x30 - 11<sup>3</sup>/<sub>4</sub>"x11<sup>3</sup>/<sub>4</sub>"**  
listello **cm 1,4x30 - 1/2"x11<sup>3</sup>/<sub>4</sub>"**  
*su rete on net sur trame auf Netz*  
**beige, dark brown,  
light brown**  
naturale matt naturelle matt

**mix listelli\***



**cm 30x30 - 11<sup>3</sup>/<sub>4</sub>"x11<sup>3</sup>/<sub>4</sub>"**  
listello **cm 1,4x30 - 1/2"x11<sup>3</sup>/<sub>4</sub>"**  
*su rete on net sur trame auf Netz*

\* Disponibile in tutti i colori della serie  
Available in all the colours of the series  
Disponibile dans tous les couleurs de la série  
Verfügbar in allen Farben  
Listelli in superficie gloss e naturale  
Listellos in gloss and matt surface  
Listelli en surface naturelle et gloss  
Listelli Gloss und Natur Oberfläche



**mix listelli  
architecture C**  
**cm 30x30 - 11<sup>3</sup>/<sub>4</sub>"x11<sup>3</sup>/<sub>4</sub>"**  
**architecture medium grey gloss**  
**cm 60x60 - 23<sup>5</sup>/<sub>8</sub>"x23<sup>5</sup>/<sub>8</sub>"**

## DECORI DECORS DÉCORS DEKORE

mosaico  
architecture A

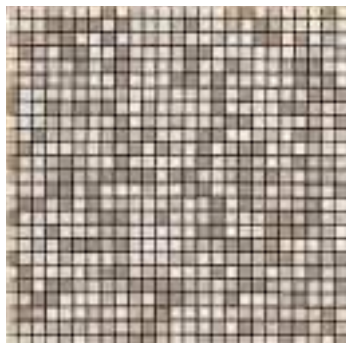

**cm 30x30 - 11<sup>3</sup>/<sub>4</sub>"x11<sup>3</sup>/<sub>4</sub>"**  
tessera **cm 1x1 - 3<sup>3</sup>/<sub>8</sub>"x3<sup>3</sup>/<sub>8</sub>"**  
*su rete on net sur trame auf Netz*  
beige, dark ivory,  
light ivory, white

mosaico  
architecture B

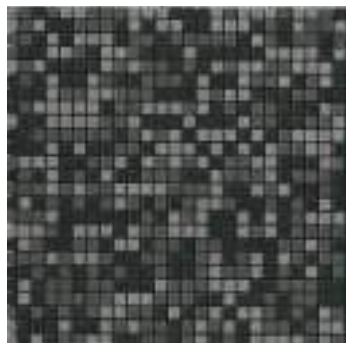

**cm 30x30 - 11<sup>3</sup>/<sub>4</sub>"x11<sup>3</sup>/<sub>4</sub>"**  
tessera **cm 1x1 - 3<sup>3</sup>/<sub>8</sub>"x3<sup>3</sup>/<sub>8</sub>"**  
*su rete on net sur trame auf Netz*  
medium grey,  
dark grey, black

mosaico  
architecture C

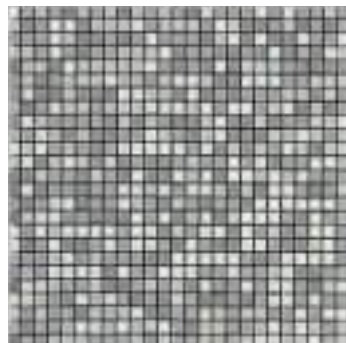

**cm 30x30 - 11<sup>3</sup>/<sub>4</sub>"x11<sup>3</sup>/<sub>4</sub>"**  
tessera **cm 1x1 - 3<sup>3</sup>/<sub>8</sub>"x3<sup>3</sup>/<sub>8</sub>"**  
*su rete on net sur trame auf Netz*  
warm grey, cool grey,  
light grey, white

mosaico  
architecture D

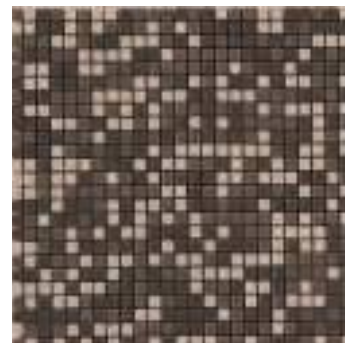

**cm 30x30 - 11<sup>3</sup>/<sub>4</sub>"x11<sup>3</sup>/<sub>4</sub>"**  
tessera **cm 1x1 - 3<sup>3</sup>/<sub>8</sub>"x3<sup>3</sup>/<sub>8</sub>"**  
*su rete on net sur trame auf Netz*  
beige, dark brown,  
light brown

mosaico  
architecture E

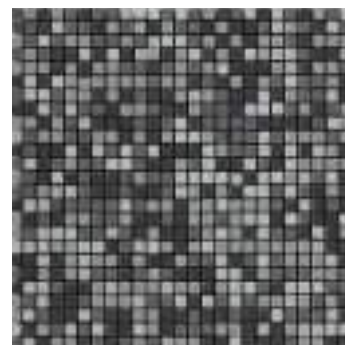

**cm 30x30 - 11<sup>3</sup>/<sub>4</sub>"x11<sup>3</sup>/<sub>4</sub>"**  
tessera **cm 1x1 - 3<sup>3</sup>/<sub>8</sub>"x3<sup>3</sup>/<sub>8</sub>"**  
*su rete on net sur trame auf Netz*  
dark grey, medium grey,  
light grey, cool grey



**mosaico architecture C**  
cm 30x30 - 11<sup>3</sup>/<sub>4</sub>"x11<sup>3</sup>/<sub>4</sub>",  
**architecture cool grey gloss**  
cm 60x60 - 23<sup>5</sup>/<sub>8</sub>"x23<sup>5</sup>/<sub>8</sub>"  
**architecture white matt**  
cm 15x90 - 5<sup>7</sup>/<sub>8</sub>"x35<sup>3</sup>/<sub>8</sub>"

# architecture

GRANITOGRES

architecture dark grey gloss cm 60x60 - 23<sup>5</sup>/<sub>8</sub>"x23<sup>5</sup>/<sub>8</sub>"

**unicolore** bianco assoluto

# unicolore

GRANITOGRES



**bianco assoluto** *levigato polished* cm 60x60 - 23<sup>5</sup>/<sub>8</sub>"x23<sup>5</sup>/<sub>8</sub>", 60x120 - 23<sup>5</sup>/<sub>8</sub>"x47<sup>1</sup>/<sub>4</sub>"

## COLORI COLOURS COULEURS FARBEN

nero



grigio cenere



grigio perla



blu forte



verde



acquamarina

# unicolore

GRANITOGRES

bianco avorio



bianco B



bianco assoluto











rosso mattone



giallo ocra



## FORMATI SIZES FORMATS FORMATE

Formati Sizes Formats Formate	 <b>cm 20x20*</b> 7 <sup>7</sup> / <sub>8</sub> "x7 <sup>7</sup> / <sub>8</sub> "	 <b>cm 30x30</b> 11 <sup>3</sup> / <sub>4</sub> "x11 <sup>3</sup> / <sub>4</sub> "	 <b>cm 40x40</b> 15 <sup>3</sup> / <sub>4</sub> "x15 <sup>3</sup> / <sub>4</sub> "	 <b>cm 15x60</b> 5 <sup>7</sup> / <sub>8</sub> "x23 <sup>5</sup> / <sub>8</sub> "	 <b>cm 30x60**</b> 11 <sup>3</sup> / <sub>4</sub> "x23 <sup>5</sup> / <sub>8</sub> "	 <b>cm 60x60**</b> 23 <sup>5</sup> / <sub>8</sub> "x23 <sup>5</sup> / <sub>8</sub> "	 <b>cm 60x120**</b> 23 <sup>5</sup> / <sub>8</sub> "x47 <sup>1</sup> / <sub>4</sub> "
Acquamarina	●	● ●					
Bianco Assoluto	●	● ●		● ●	● ●	● ●	● ●
Bianco Avorio	● ●	● ● ●	● ●				● ●
Bianco B	● ●	● ● ●	● ●	● ●	● ●	● ●	● ●
Blu Forte	●	● ●					
Giallo Ocra	●	● ●					
Grigio Cenere	● ●	● ● ●					
Grigio Perla	●	● ●					
Nero	●	● ●	● ●				
Rosso Mattone	●	● ●					
Verde	●	● ●					
	mm 8	mm 8	mm 9	mm 9	mm 10 mm 9♦	mm 10	mm 10



Uniforme  
Uniform  
Uniforme  
Einheitliche

Vedi pagina: See page: Voir page : Siehe Seite: **448**

● Naturale Matt Naturelle Matt **R9 A**  
● Levigata Polished Polie Poliert  
● Technic **R10**

\* Spessore su superficie naturale Thickness on matt surface Épaisseur sur surface naturelle Stärke der Fliesen mit Mattoberfläche

\*\* Rettificate in un unico calibro Rectified version in a single caliber Rectifiés en un unique calibre Boden Sie in einem einzigen Kaliber

♦ Solo Only Seulement Nur **Bianco Assoluto**

Per superfici speciali antiscivolo e spessori maggiorati vedere catalogo Technic For increased thicknesses and special no-slip surfaces see the Technic catalogue  
Pour des surfaces antiderapantés et les épaisseurs majorés, voir catalogue Technic Für sonderrutschhemmende Oberflächen und Stärken siehe Katalogue Technic

Caratteristiche tecniche e imballi a pagina: Technical features and packing on page: Caractéristiques techniques et emballages à la page: Technische Eigenschaften und Verpackungen auf Seite: **434**



bianco B, grigio cenere, nero cm 30x30 - 11<sup>3</sup>/<sub>4</sub>"x11<sup>3</sup>/<sub>4</sub>"



## PEZZI SPECIALI TRIMS ACCESSOIRES FORMSTÜCKE

# unicolore

GRANITOGRES

**Battiscopa Bullnose**  
**Plinthe à bord arrondi**  
**Stehsockel**  
cm 9x30 - 3½"x11¾"  
cm 9x40 - 3½"x15¾"  
cm 10x20 - 4"x7⅞"

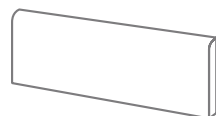

**Zoccolo a raccordo a taglio retto\***  
**Cove base - straight top\***  
**Plinthe à gorge avec bord vif\***  
**Hohlkehlssockel (scharfkantig)\***  
cm 10x20 - 4"x7⅞"

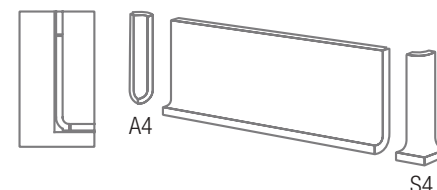

**Gradino Step tread**  
**Nez de marche Stufenplatte**  
cm 30x30 - 11¾"x11¾"

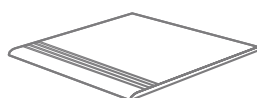

**Zoccolo ad appoggio smussato\***  
**Sit-on skirting - bevelled top\***  
**Plinthe à talon avec bord arrondi\***  
**Aufsetzsockel mit abgerundeter Kante\***  
cm 10x20 - 4"x7⅞"

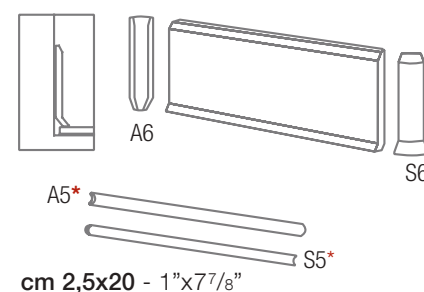

**Listello Listel**  
**Listel Zeierleiste**  
cm 9x30 - 3½"x11¾"  
cm 9x40 - 3½"x15¾"



**Tozzetto Insert**  
**Cabochon Einleger**  
cm 9x9 - 3½"x3½"

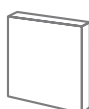

**Sguscetta\* Cove\***  
**Gorge\* Rinnleiste\***  
cm 4x20 - 1⅝"x7⅞"

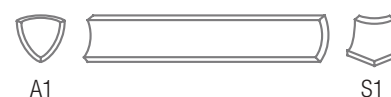

\* Produzione corrente solo nei colori: Currently produced only in the following colours: Productions courantes seulement dans les couleurs: Aktuelle Produktion nur in den Farben:  
**Bianco Avorio, Bianco B, Grigio Cenere**

Altri colori sono prodotti solo su richiesta Other colours are produced on demand Autres teintes disponibles sur demand Andere Farben nur auf Antrag

grigio cenere cm 30x30 - 11¾"x11¾"



# caleidoscopio

ECOGRES



**pistacchio, liquirizia** cm 20x20 - 7<sup>7</sup>/<sub>8</sub>"x7<sup>7</sup>/<sub>8</sub>"

## COLORI COLOURS COULEURS FARBEN

liquirizia

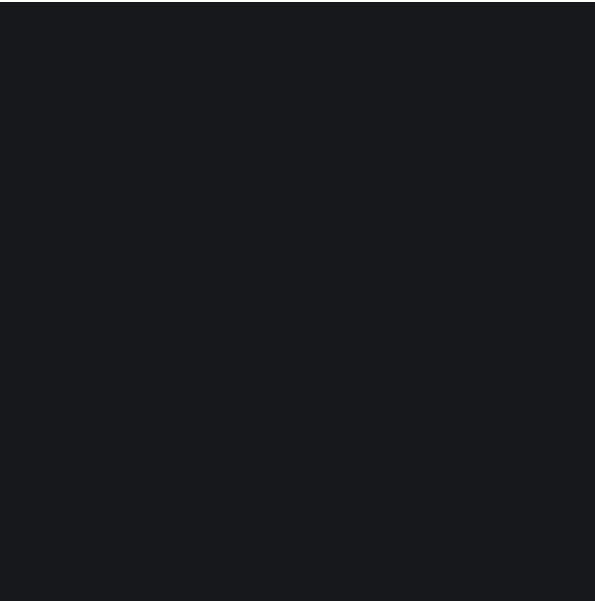

cobalto



marina

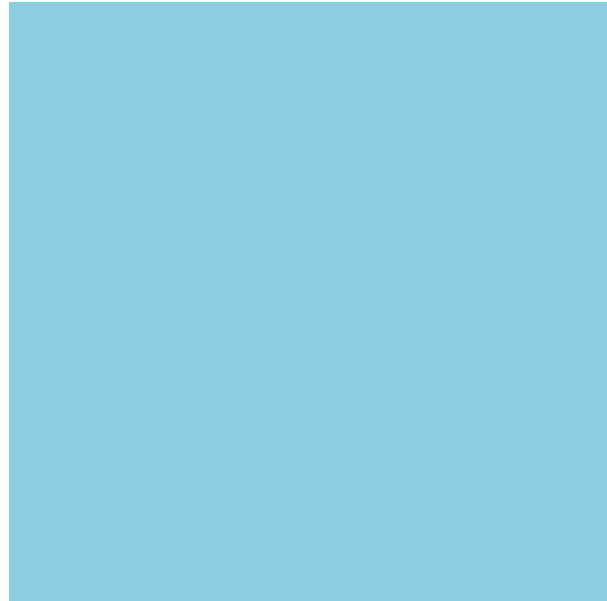

oliva



pistacchio



menta

# caleidoscopio

ECOGRES

cielo

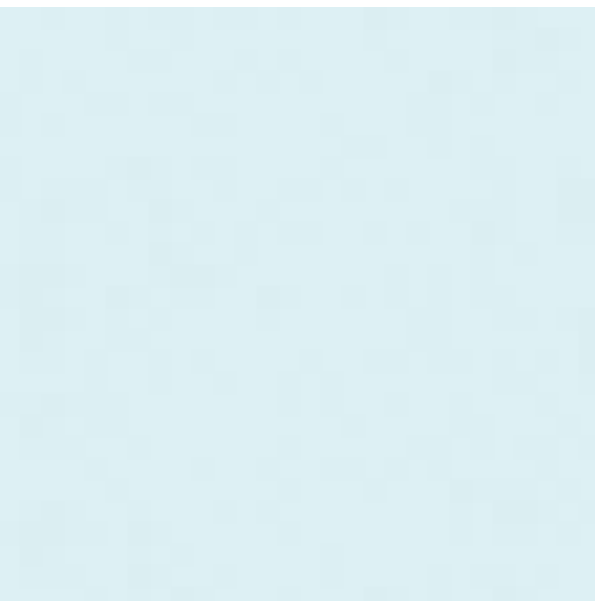

granita



ghiaccio

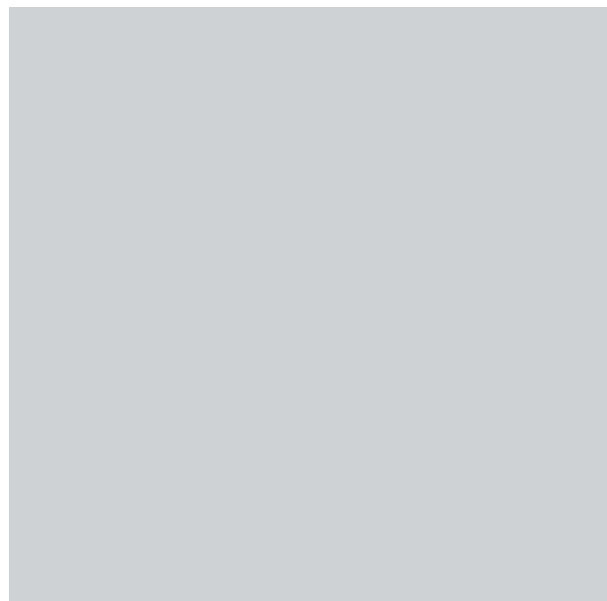

antracite



betulla

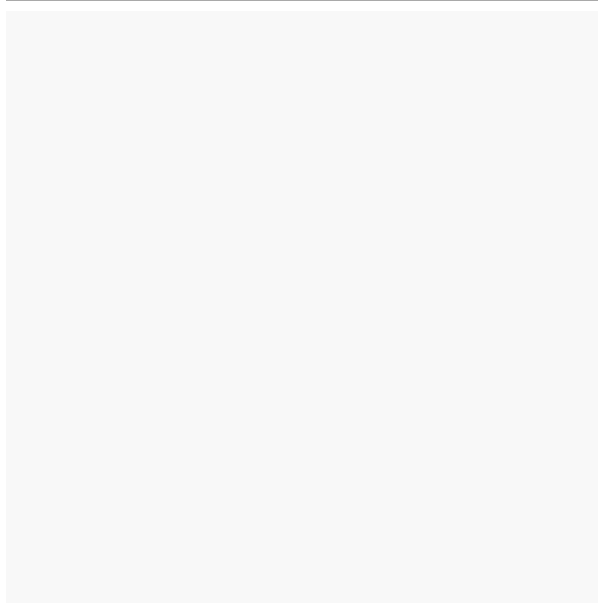

## COLORI COLOURS COULEURS FARBEN

rosso selenio

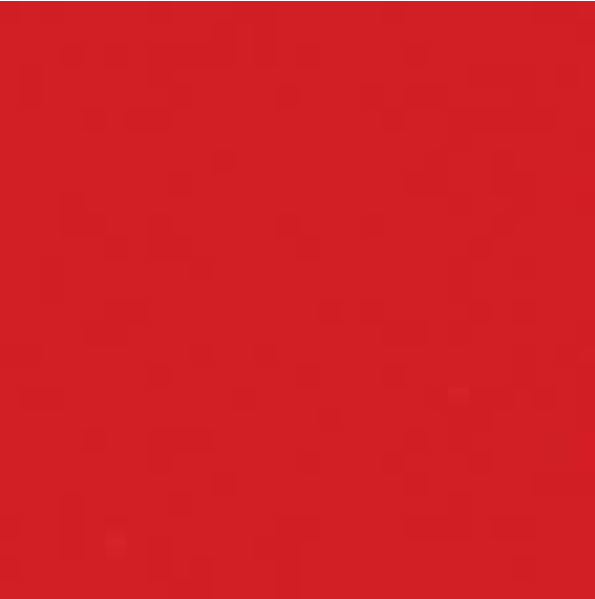

ocra



caramello







avorio

## FORMATI SIZES FORMATS FORMATE

# caleidoscopio

ECOGRES

Formati Sizes Formats Formate		 <b>cm 20x20</b> 7 <sup>7</sup> / <sub>8</sub> "x7 <sup>7</sup> / <sub>8</sub> "
Antracite G3*		●
Avorio G3*		●
Betulla G3*		● ●
Caramel G3*		●
Cielo G3*		●
Cobalto G3*		●
Ghiaccio G3*		●
Granita G3*		● ●
		mm 7,3

Formati Sizes Formats Formate		 <b>cm 20x20</b> 7 <sup>7</sup> / <sub>8</sub> "x7 <sup>7</sup> / <sub>8</sub> "
Liquirizia G2*		●
Marina G3*		●
Menta G3*		●
Ocra G3*		●
Oliva G2*		●
Pistacchio G2*		●
Rosso selenio G2*		●
		mm 7,3



Uniforme  
Uniform  
Uniforme  
Einheitliche

Vedi pagina: See page: Voir page : Siehe Seite: **448**

● Naturale Matt Naturelle Matt  
● Grip **R10**

\* Vedi pagina: See page: Voir page Siehe Seite: **447**

Rettificate in un unico calibro Rectified version in a single calibr Rectifiés en un unique calibre Boden Sie in einem einzigen Kaliber

Caratteristiche tecniche e imballi a pagina: Technical features and packing on page: Caractéristiques techniques et emballages à la page: Technische Eigenschaften und Verpackungen auf Seite: **446**

## PEZZI SPECIALI TRIMS ACCESSOIRES FORMSTÜCKE

**Battiscopa\* Bullnose\***  
**Plinthe à bord arrondi \***  
**Stehsockel\***  
cm 8x33 - 3<sup>1</sup>/<sub>2</sub>"x11<sup>3</sup>/<sub>4</sub>"



**Sguscetta\* Cove\***  
**Gorge\* Rinneleiste\***  
cm 2,5x20 - 1"x7<sup>7</sup>/<sub>8</sub>"

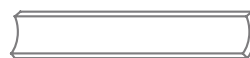

**Conchiglia\*** **Piè d'oca\***  
cm 2,5x2,5 - 1"x 1" cm 2,5x3 - 1"x1<sup>1</sup>/<sub>8</sub>"



\* Produzione corrente solo nei colori: Currently produced only in the following colours: Productions courantes seulement dans les couleurs: Aktuelle Produktion nur in den Farben: **Betulla**

## DECORI DECORS DÉCORS DEKORE

**matita\*\***



cm 2x20 - 3<sup>3</sup>/<sub>4</sub>"x7<sup>7</sup>/<sub>8</sub>"

**london\*\***



cm 3x20 - 1<sup>1</sup>/<sub>8</sub>"x7<sup>7</sup>/<sub>8</sub>"

**spigolo\*\***



cm 3x2 - 1<sup>1</sup>/<sub>8</sub>"x3<sup>3</sup>/<sub>4</sub>"

\*\* Disponibile nei colori: Available in the colours: Disponible dans les couleurs: Verfügbar in den folgenden Farben: **Caramel, Cobalto, Granita, Marina, Menta**





# elementi

GRANITOGRES



**cemento 060 , ebano 070** cm 12,5x25 - 5"x10", cm 12,5x12,5 - 5"x5"

## COLORI COLOURS COULEURS FARBEN

talco 010



avorio 011



cemento 060

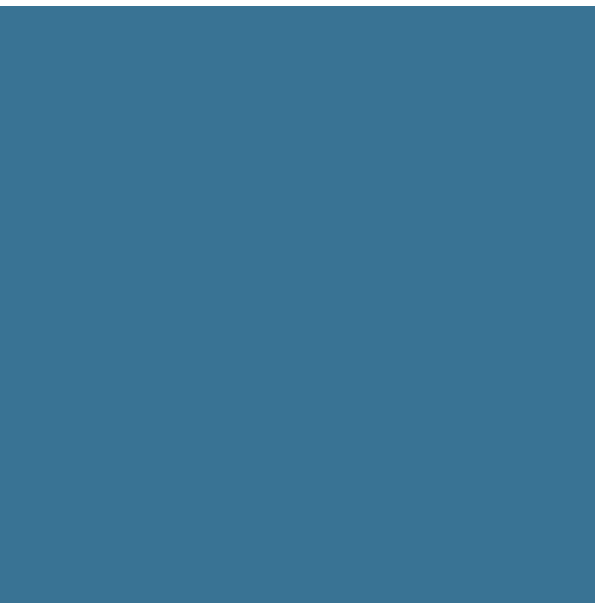
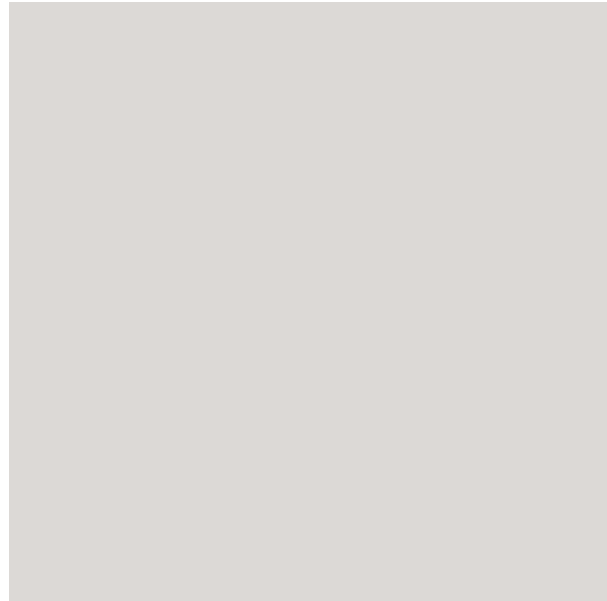

mare 021

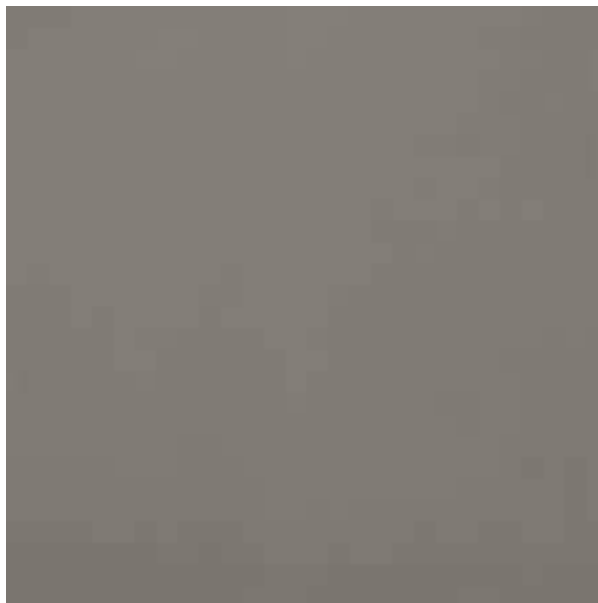

basalto 061







ebano 070

# FORMATI SIZES FORMATS FORMATE

# elementi

## GRANITOGRES

	 <b>1120</b>	 <b>1121 break</b>	 <b>1100</b>	 <b>1000</b>
Formati Sizes Formats Formate	<b>cm M* 12,5x12,5</b> 4 <sup>7</sup> / <sub>8</sub> "x4 <sup>7</sup> / <sub>8</sub> "	<b>cm M* 12,5x12,5 2 pc</b> 4 <sup>7</sup> / <sub>8</sub> "x4 <sup>7</sup> / <sub>8</sub> "	<b>cm M* 12,5x25</b> 4 <sup>7</sup> / <sub>8</sub> "x9 <sup>7</sup> / <sub>8</sub> "	<b>cm M* 25x25</b> 9 <sup>7</sup> / <sub>8</sub> "x9 <sup>7</sup> / <sub>8</sub> "
Talco 010	● ●	●	● ●	● ● ●
Cemento 060			● ●	● ● ●
Basalto 061			● ●	● ●
Ebano 070			● ●	● ●
Avorio 011	● ●	●	● ●	● ●
Mare 021	● ●		● ●	● ●
	mm 8	mm 8	mm 8	mm 8

- Matt
- Pinhead
- Roccia

	Misure nominali Nominal sizes Cotes nominales Nennmasse	Misure di fabbricazione in calibro 0 Real size in cal. 0 Dimension de fabrication calibre 0 Herstellmasse im Kaliber 0
<b>1120</b>	<b>cm M* 12,5x12,5</b> <b>M* 4<sup>7</sup>/<sub>8</sub>"x4<sup>7</sup>/<sub>8</sub>"</b>	<b>mm 118x118</b> 4 <sup>5</sup> / <sub>8</sub> "x4 <sup>4</sup> / <sub>64</sub> "
<b>1121 break**</b>	<b>cm M* 12,5x12,5</b> <b>M* 4<sup>7</sup>/<sub>8</sub>"x4<sup>7</sup>/<sub>8</sub>" x 2 pc</b>	<b>mm 118x118</b> 4 <sup>5</sup> / <sub>8</sub> "x4 <sup>5</sup> / <sub>8</sub> " x 2 pc
<b>1100</b>	<b>cm M* 12,5x25</b> <b>M* 4<sup>7</sup>/<sub>8</sub>"x9<sup>7</sup>/<sub>8</sub>"</b>	<b>mm 118x243</b> 9 <sup>9</sup> / <sub>16</sub> "x9 <sup>9</sup> / <sub>16</sub> "
<b>1000</b>	<b>cm M* 25x25</b> <b>M* 9<sup>7</sup>/<sub>8</sub>"x9<sup>7</sup>/<sub>8</sub>"</b>	<b>mm 243x243</b> 9 <sup>9</sup> / <sub>16</sub> "x9 <sup>9</sup> / <sub>16</sub> "

\* M = formato modulare modular size format modulaire modulformat

\*\* Da separare in cantiere A break on job site À séparer en chantier Spaltplatten auf Baustelle zubereiten



Importante: la modularità dei formati si ottiene con fuga di 7 mm Important: modularity of different sizes is based on 7 mm grouting joints  
 Important: la modularité des formats est calculée avec un joint de 7 mm Wichtig: Für Modulverlegung die empfohlene Fugenbreite ist 7 mm

Caratteristiche tecniche e imballi a pagina: Technical features and packing on page: Caractéristiques techniques et emballages à la page: Technische Eigenschaften und Verpackungen auf Seite: **434**

# SUPERFICI SURFACES SURFACES OBERFLÄCHEN





●  
Matt

DIN 51097 B	XP P 05-010 PN 18	
DIN 51130 R 10 V	XP P 05-010 PC 10	





●  
Pinhead

DIN 51097 C	XP P 05-010 PN 24	
DIN 51130 R 11 V 6	XP P 05-010 PC 20	



●  
Roccia

DIN 51097 C	XP P 05-010 PN 24	
DIN 51130 R 12 V	XP P 05-010 PC 27	



# landscape

GRESPLUS



tundra 100, ocean 202 cm 12,5x25 - 4<sup>7</sup>/<sub>8</sub>"x9<sup>7</sup>/<sub>8</sub>"

## COLORI COLOURS COULEURS FARBEN

tundra 100

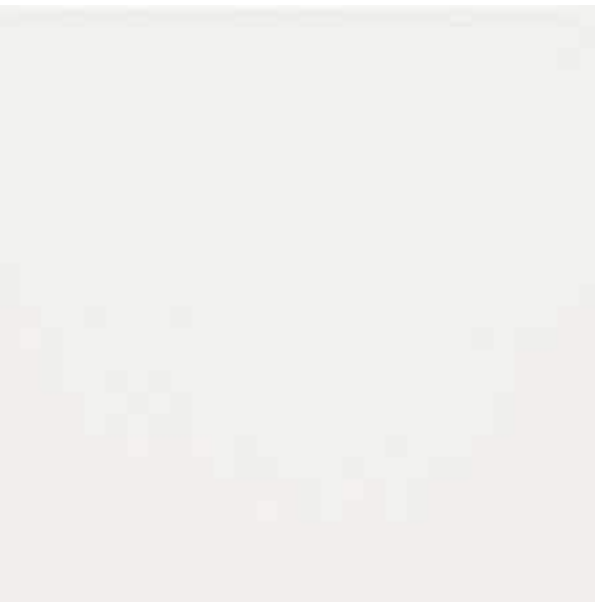

bay 200



beach 101



lava 700



artic 701



bahama 501

# landscape























GRESPLUS



ocean 202



tundra 100, LS mix 820

## FORMATI SIZES FORMATS FORMATE

	 <b>1120</b>	 <b>1121 break</b>	 <b>2100</b>	 <b>1100</b>	 <b>1000</b>
Formati Sizes Formats Formate	<b>cm M* 12,5x12,5</b> 4 <sup>7</sup> / <sub>8</sub> "x4 <sup>7</sup> / <sub>8</sub> "	<b>cm M* 12,5x12,5 2 pc</b> 4 <sup>7</sup> / <sub>8</sub> "x4 <sup>7</sup> / <sub>8</sub> "	<b>cm M* 6,25x25</b> 2 <sup>1</sup> / <sub>2</sub> "x9 <sup>7</sup> / <sub>8</sub> "	<b>cm M* 12,5x25 cm</b> 4 <sup>7</sup> / <sub>8</sub> "x9 <sup>7</sup> / <sub>8</sub> "	<b>cm M 25x25</b> 9 <sup>7</sup> / <sub>8</sub> "x9 <sup>7</sup> / <sub>8</sub> "
Tundra 100					
Beach 101					
Bay 200					
Ocean 202					
Artic 701					
Bahama 501					
Lava 700					
	mm 8	mm 8	mm 8	mm 8	mm 8

	Misure nominali Nominal sizes Cotes nominales Nennmasse	Misure di fabbricazione in calibro 0 Real size in cal. 0 Dimension de fabrication calibre 0 Herstellmasse im Kaliber 0	 Satin  Friction  Grip
<b>1120</b>	<b>cm M* 12,5x12,5</b> M* 4 <sup>7</sup> / <sub>8</sub> "x4 <sup>7</sup> / <sub>8</sub> "	<b>mm 118x118</b> 4 <sup>5</sup> / <sub>8</sub> "x4 <sup>41</sup> / <sub>64</sub> "	
<b>1121 break**</b>	<b>cm M* 12,5x12,5</b> M* 4 <sup>7</sup> / <sub>8</sub> "x4 <sup>7</sup> / <sub>8</sub> " x 2 pc	<b>mm 118x118</b> 4 <sup>5</sup> / <sub>8</sub> "x4 <sup>5</sup> / <sub>8</sub> " x 2 pc	
<b>2100</b>	<b>cm M* 6,5x25</b> M* 2 <sup>1</sup> / <sub>2</sub> "x9 <sup>7</sup> / <sub>8</sub> "	<b>mm 55,5x243</b> 2 <sup>1</sup> / <sub>8</sub> "x9 <sup>9</sup> / <sub>16</sub> "	
<b>1100</b>	<b>cm M* 12,5x25</b> M* 4 <sup>7</sup> / <sub>8</sub> "x9 <sup>7</sup> / <sub>8</sub> "	<b>mm 118x243</b> 4 <sup>5</sup> / <sub>8</sub> "x9 <sup>9</sup> / <sub>16</sub> "	
<b>1000</b>	<b>cm M* 25x25</b> M* 9 <sup>7</sup> / <sub>8</sub> "x9 <sup>7</sup> / <sub>8</sub> "	<b>mm 243x243</b> 9 <sup>9</sup> / <sub>16</sub> "x9 <sup>9</sup> / <sub>16</sub> "	

\* M = formato modulare modular size format modulaire modulformat

\*\* Da separare in cantiere A break on job site À séparer en chantier Spaltplatten auf Baustelle zubereiten

Importante: la modularità dei formati si ottiene con fuga di 7 mm Important: modularity of different sizes is based on 7 mm grouting joints  
Important: la modularité des formats est calculée avec un joint de 7 mm Wichtig: Für Modulverlegung die empfohlene Fugenbreite ist 7 mm

Caratteristiche tecniche e imballi a pagina: Technical features and packing on page: Caractéristiques techniques et emballages à la page: Technische Eigenschaften und Verpackungen auf Seite: **444**

tundra 100, ocean 202, bay 200 cm 25x25 - 10"x10"





# landscape

GRESPLUS

## SUPERFICI SURFACES SURFACES OBERFLÄCHEN



● Satin

DIN 51097  
A

XP P 05-010  
PN 12



● Friction

DIN 51097  
B

XP P 05-010  
PN 18



● Grip

DIN 51097  
C

XP P 05-010  
PN 24



## DECORI DECORS DÉCORS DEKORE

**LS mix 820\***

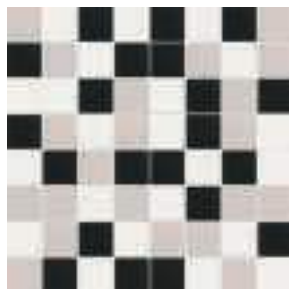

cm M 25x25 - 10"x10"  
Satin  
Tundra 100, Lava 700,  
Artic 701

**LS mix 840\***

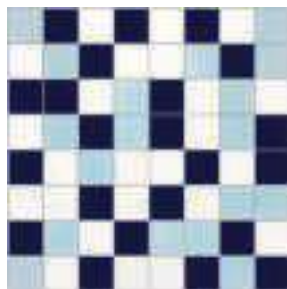

cm M 25x25 - 10"x10"  
Satin  
Tundra 100, Bay 200,  
Ocean 202

**LS uni bay\***



cm M 25x25 - 10"x10"  
Satin, Grip

**LS uni ocean\***



cm M 25x25 - 10"x10"  
Satin, Grip

**LS uni tundra\***

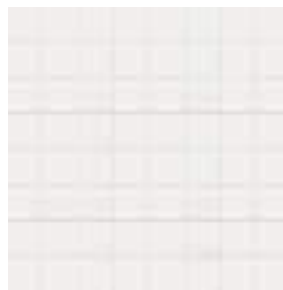

cm M 25x25 - 10"x10"  
Satin, Grip

\* Fornito con carta davanti Supplied with paper on front side Fournie avec papier sur la belle face Geliefert mit Papier auf Vorderseite

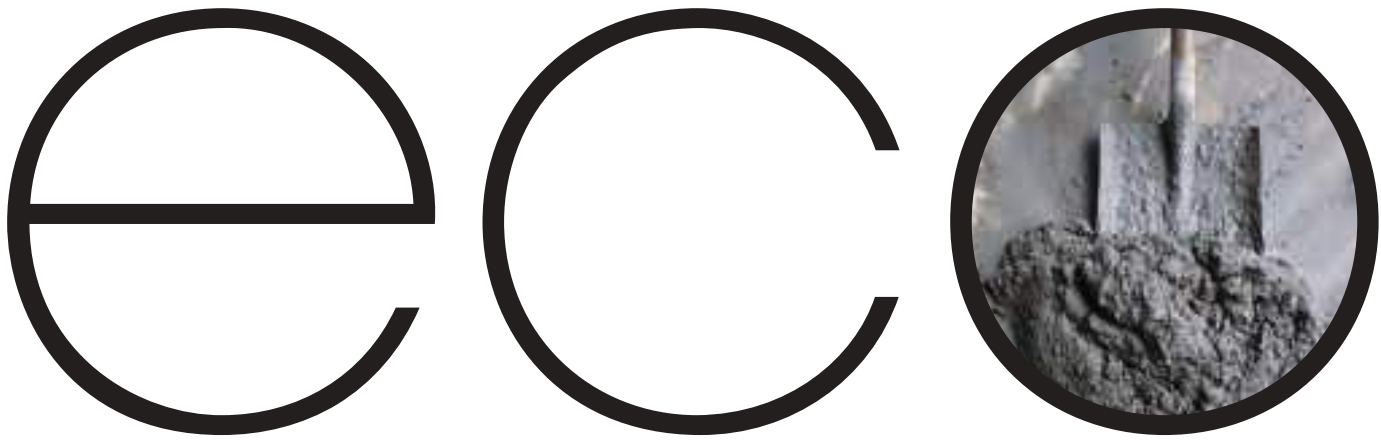

eco**concrete** éco**ciment** öko**zement**

**cemento**

# ecocemento

- 348 **manhattan**
- 354 **r-evolution**
- 360 **beton**
- 368 **cemento**
- 378 **resina**
- 384 **spazio**
- 390 **eco concrete**
- 394 **opus**
- 404 **città**
- 408 **living**

501

**CEMENTO**

Composto di silicati e alluminati di calcio ottenuto attraverso la cottura a elevata temperatura di calcare e argilla o di marna. La materia prima risultante viene macinata e addizionata con altri componenti per specializzarne le prestazioni in funzione dell'impiego. Miscelato con acqua, si idrata e solidifica progressivamente.

**CONCRETE**

Composed of silicates and calcium aluminates, made by cooking limestone and clay or marl at high temperatures. The resulting material is crushed and mixed with other ingredients to make it perform according to its intended use. Mixed with water, it progressively gets hydrated and sets.

84





# manhattan

GRANITOKER



soho cm 90x90 - 35<sup>3</sup>/<sub>8</sub>"x35<sup>3</sup>/<sub>8</sub>"

## COLORI COLOURS COULEURS FARBEN

soho



tribeca



queens



harlem



# manhattan

GRANITOKER



queens cm 90x90 - 35<sup>3</sup>/<sub>8</sub>"x35<sup>3</sup>/<sub>8</sub>"

## FORMATI SIZES FORMATS FORMATE

Formati Sizes Formats Formate	<b>cm 30x60</b> 11 <sup>3</sup> / <sub>4</sub> "x23 <sup>5</sup> / <sub>8</sub> "	<b>cm 60x60</b> 23 <sup>5</sup> / <sub>8</sub> "x23 <sup>5</sup> / <sub>8</sub> "	<b>cm 60x60</b> 23 <sup>5</sup> / <sub>8</sub> "x23 <sup>5</sup> / <sub>8</sub> "	<b>cm 45x45</b> 17 <sup>3</sup> / <sub>4</sub> "x17 <sup>3</sup> / <sub>4</sub> "	<b>cm 45x90</b> 17 <sup>3</sup> / <sub>4</sub> "x35 <sup>3</sup> / <sub>8</sub> "	<b>cm 90x90</b> 35 <sup>3</sup> / <sub>8</sub> "x35 <sup>3</sup> / <sub>8</sub> "	<b>cm 90x90</b> 35 <sup>3</sup> / <sub>8</sub> "x35 <sup>3</sup> / <sub>8</sub> "
Superfici Surfaces Surfaces Oberflächen	● ●	● ●	●	●	● ●	● ●	●
▼ ▲	mm 10 mm 9 mm 9*	mm 10	mm 20	mm 9	mm 10	mm 10	mm 20



Accentuata  
Accentuated  
Importante  
Starke

Vedi pagina: See page: Voir page : Siehe Seite: **448**

● Naturale Matt Naturelle Matt **R9 A**  
● Grip **R11 A**

Rettificate in un unico calibro Rectified version in a single caliber Rectifiés en un unique calibre Boden Sie in einem einzigen Kaliber.

\* Non rettificato Unrectified Non rectifié Nicht kalibriert

Nel caso di combinazioni di formati di spessori diversi, specificarlo espressamente nell'ordine

Please specify in your order if you wish to purchase formats including more than one thickness

Prière de spécifier dans votre commande si vous souhaitez acheter des formats avec différentes épaisseurs

Bitte weisen Sie im Bestellungsformular ausdrücklich darauf hin, wenn Sie Formatkombinationen mit verschiedenen Stärken wünschen

Caratteristiche tecniche e imballi a pagina: Technical features and packing on page: Caractéristiques techniques et emballages à la page: Technische Eigenschaften und Verpackungen auf Seite: **440**

## PEZZI SPECIALI TRIMS ACCESSOIRES FORMSTÜCKE

▲ 2pcs 45°

**Battiscopa Bullnose**  
**Plinthe à bord arrondi**  
**Stehsockel**  
cm 9x90 - 3<sup>1</sup>/<sub>2</sub>"x35<sup>3</sup>/<sub>8</sub>"  
cm 9x60 - 3<sup>1</sup>/<sub>2</sub>"x23<sup>5</sup>/<sub>8</sub>"



**Gradino Step tread**  
**Nez de marche Stufenplatte**  
cm 30x90 - 11<sup>3</sup>/<sub>4</sub>"x35<sup>3</sup>/<sub>8</sub>"  
cm 30x60 - 11<sup>3</sup>/<sub>4</sub>"x23<sup>5</sup>/<sub>8</sub>"

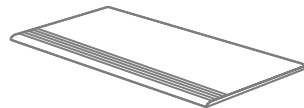

**Gradone (assemblato)**  
cm 90x33 - 35<sup>3</sup>/<sub>8</sub>"x13"

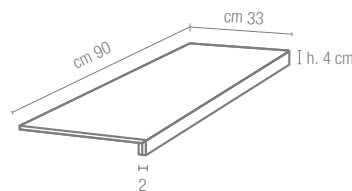

**Angolare (assemblato)**  
cm 90x33 - 35<sup>3</sup>/<sub>8</sub>"x13"

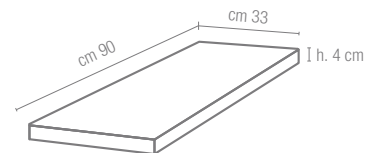

**Art. 9550**  
cm 33x60 - 13"x23<sup>5</sup>/<sub>8</sub>"

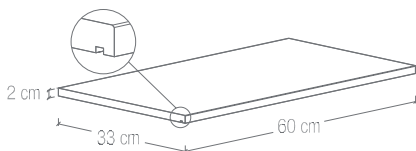

**Art. 9557** ▲  
cm 60x60 - 23<sup>5</sup>/<sub>8</sub>"x23<sup>5</sup>/<sub>8</sub>"

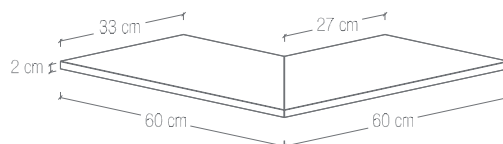

**Art. 9558** ▲  
cm 60x60 - 23<sup>5</sup>/<sub>8</sub>"x23<sup>5</sup>/<sub>8</sub>"

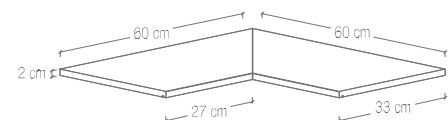

DECORI DECORS DÉCORS DEKORE

# manhattan

GRANITOKER

mosaico 6x6 harlem

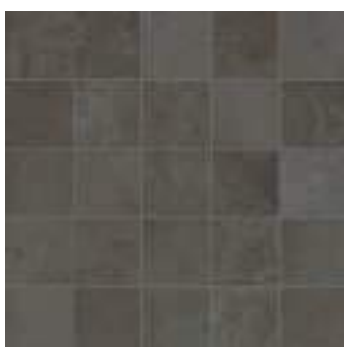

**cm 30x30** - 11<sup>3</sup>/<sub>4</sub>"x11<sup>3</sup>/<sub>4</sub>"  
tessera **cm 6x6** - 2<sup>3</sup>/<sub>8</sub>"x2<sup>3</sup>/<sub>8</sub>"  
*su rete on net sur trame auf Netz*

mosaico 6x6 queens

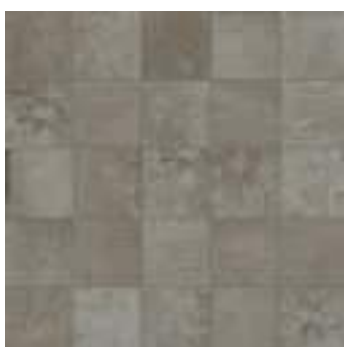

**cm 30x30** - 11<sup>3</sup>/<sub>4</sub>"x11<sup>3</sup>/<sub>4</sub>"  
tessera **cm 6x6** - 2<sup>3</sup>/<sub>8</sub>"x2<sup>3</sup>/<sub>8</sub>"  
*su rete on net sur trame auf Netz*

mosaico 6x6 soho



**cm 30x30** - 11<sup>3</sup>/<sub>4</sub>"x11<sup>3</sup>/<sub>4</sub>"  
tessera **cm 6x6** - 2<sup>3</sup>/<sub>8</sub>"x2<sup>3</sup>/<sub>8</sub>"  
*su rete on net sur trame auf Netz*

mosaico 6x6 tribeca



**cm 30x30** - 11<sup>3</sup>/<sub>4</sub>"x11<sup>3</sup>/<sub>4</sub>"  
tessera **cm 6x6** - 2<sup>3</sup>/<sub>8</sub>"x2<sup>3</sup>/<sub>8</sub>"  
*su rete on net sur trame auf Netz*



tribeca cm 90x90 - 35<sup>3</sup>/<sub>8</sub>"x35<sup>3</sup>/<sub>8</sub>"



# r-evolution

GRANITOKER



light pink cm 90x90 - 35<sup>3</sup>/<sub>8</sub>"x35<sup>3</sup>/<sub>8</sub>", cm 90x180 - 35<sup>3</sup>/<sub>8</sub>"x70<sup>7</sup>/<sub>8</sub>"

## COLORI COLOURS COULEURS FARBEN

r-evolution black



r-evolution dark grey



r-evolution blue



r-evolution terra



r-evolution tortora



r-evolution sand

# r-evolution

GRANITOKER

r-evolution azure



r-evolution green



r-evolution light pink



r-evolution grey





r-evolution white



r-evolution total white

## FORMATI SIZES FORMATS FORMATE

Formati Sizes Formats Formate	<b>cm 30x60</b> 11 <sup>3</sup> / <sub>4</sub> "x23 <sup>5</sup> / <sub>8</sub> "	<b>cm 60x60</b> 23 <sup>5</sup> / <sub>8</sub> "x23 <sup>5</sup> / <sub>8</sub> "	<b>cm 45x90</b> 17 <sup>3</sup> / <sub>4</sub> "x35 <sup>3</sup> / <sub>8</sub> "	<b>cm 30x120</b> 11 <sup>3</sup> / <sub>4</sub> "x47 <sup>1</sup> / <sub>4</sub> "	<b>cm 60x120</b> 23 <sup>5</sup> / <sub>8</sub> "x47 <sup>1</sup> / <sub>4</sub> "	<b>cm 90x90</b> 35 <sup>3</sup> / <sub>8</sub> "x35 <sup>3</sup> / <sub>8</sub> "	<b>cm 90x180</b> 35 <sup>3</sup> / <sub>8</sub> "x70 <sup>7</sup> / <sub>8</sub> "
Superfici Surfaces Surfaces Oberflächen	● ●	● ●	● ●*	●	● ●	● ●*	●
 	mm 10 mm 9**	mm 10	mm 10	mm 10	mm 10	mm 10	mm 10



Vedi pagina: See page: Voir page : Siehe Seite: **448**

- Naturale Matt Naturelle Matt
- Naturale Matt Naturelle Matt **R10 A+B PTV>36**
- \* Naturale Matt Naturelle Matt **R10 A+B PTV>36**  
su richiesta on request sur demande Auf Anfrage können

Rettificate in un unico calibro Rectified version in a single caliber Rectifiés en un unique calibre Boden Sie in einem einzigen Kaliber

\*\* Solo superficie Naturale Matt surface only Seulement surface naturelle Nur in der Matt Oberfläche

Consigliata per residenziale e commerciale leggero Suitable for residential or light commercial Conseillé pour résidentielle et commerciale à circulation légère Geeignet für wohn oder leichte kommerzielle

Caratteristiche tecniche e imballi a pagina: Technical features and packing on page: Caractéristiques techniques et emballages à la page: Technische Eigenschaften und Verpackungen auf Seite: **440**

## PEZZI SPECIALI TRIMS ACCESSOIRES FORMSTÜCKE

**Battiscopa Bullnose**  
Plinthe à bord arrondi  
Stehsockel  
cm 7x60 - 2<sup>3</sup>/<sub>4</sub>"x23<sup>5</sup>/<sub>8</sub>"  
cm 7x90 - 2<sup>3</sup>/<sub>4</sub>"x35<sup>3</sup>/<sub>8</sub>"



**Gradino Step tread**  
Nez de marche Stufenplatte  
cm 30x60 - 11<sup>3</sup>/<sub>4</sub>"x23<sup>5</sup>/<sub>8</sub>"  
cm 30x120 - 11<sup>3</sup>/<sub>4</sub>"x47<sup>1</sup>/<sub>4</sub>"

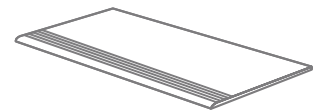

**Gradone (assemblato)**  
cm 120x33 - 47<sup>1</sup>/<sub>4</sub>"x13"

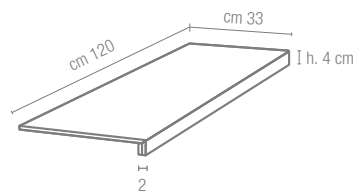

**Angolare (assemblato)**  
cm 120x33 - 47<sup>1</sup>/<sub>4</sub>"x13"

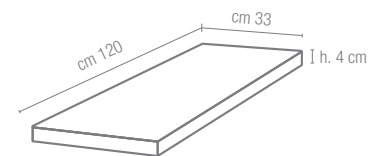

r-evolution blue cm 60x120 - 23<sup>5</sup>/<sub>8</sub>"x47<sup>1</sup>/<sub>4</sub>"  
stripes D cm 60x120 - 23<sup>5</sup>/<sub>8</sub>"x47<sup>1</sup>/<sub>4</sub>"  
mosaico 6x6 blue cm 30x30 - 11<sup>3</sup>/<sub>4</sub>"x11<sup>3</sup>/<sub>4</sub>"



# r-evolution

GRANITOKER

## DECORI DECORS DÉCORS DEKORE

stripes\*\*



cm 60x120 - 23<sup>5</sup>/<sub>8</sub>" x 47<sup>1</sup>/<sub>4</sub>"

bacchetta r-evo\*\*\*

cm 60x0,5 - 23<sup>5</sup>/<sub>8</sub>" x 1<sup>1</sup>/<sub>4</sub>"

r-evo row\*



cm 30x60 - 11<sup>3</sup>/<sub>4</sub>" x 23<sup>5</sup>/<sub>8</sub>"

Abbinabile a Combined with Combiné avec Kombiniert mit

inserto r-evo\*\*\*

cm 16,5x0,5 - 6<sup>1</sup>/<sub>2</sub>" x 1<sup>1</sup>/<sub>4</sub>"

mosaico 6x6\*



cm 30x30 - 11<sup>3</sup>/<sub>4</sub>" x 11<sup>3</sup>/<sub>4</sub>"  
tessera cm 6x6 - 2<sup>3</sup>/<sub>8</sub>" x 2<sup>3</sup>/<sub>8</sub>"  
su rete on net sur trame auf Netz

esagoni\*



cm 30x28,9 - 11<sup>3</sup>/<sub>4</sub>" x 11<sup>3</sup>/<sub>8</sub>"  
su rete on net sur trame auf Netz

\* Disponibile in tutti i colori della serie Available in all the colours of the series Disponible dans toutes les couleurs de la série Verfügbar in allen Farben

\*\* Disponibile nei colori: Available in the colours: Disponible dans les couleurs : Verfügbar in den folgenden Farben: **A** (Total White/Black), **B** (White/Grey), **C** (Sand/Tortora), **D** (Total White/Blue)

\*\*\* Disponibile nei colori: Available in the colours: Disponible dans les couleurs : Verfügbar in den folgenden Farben: **Black, Blue, Dark Grey, Green, Light Pink, Terra**



# beton

GRANITOKER



beton ivory cm 75,5x151 - 29<sup>3</sup>/<sub>4</sub>"x59<sup>1</sup>/<sub>2</sub>"

## COLORI COLOURS COULEURS FARBEN

beton dark



beton pearl



beton mud



beton sand



beton ivory



# beton

GRANITOKER



beton dark cm 75,5x75,5 - 29<sup>3</sup>/<sub>4</sub>"x29<sup>3</sup>/<sub>4</sub>"

## FORMATI SIZES FORMATS FORMATE

Formati Sizes Formats Formate	<b>cm 30x60</b> 11 <sup>3</sup> / <sub>4</sub> "x23 <sup>5</sup> / <sub>8</sub> "	<b>cm 60x60</b> 23 <sup>5</sup> / <sub>8</sub> "x23 <sup>5</sup> / <sub>8</sub> "	<b>cm 37,5x75,5</b> 14 <sup>3</sup> / <sub>4</sub> "x29 <sup>3</sup> / <sub>4</sub> "	<b>cm 75,5x75,5</b> 29 <sup>3</sup> / <sub>4</sub> "x29 <sup>3</sup> / <sub>4</sub> "	<b>cm 75,5x151</b> 29 <sup>3</sup> / <sub>4</sub> "x59 <sup>1</sup> / <sub>2</sub> "
Superfici Surfaces Surfaces Oberflächen	●	●	●	●	●
 	mm 10 mm 9	mm 10	mm 10 mm 9	mm 10	mm 10



Media  
Medium  
Modérée  
Mittlere

Vedi pagina: See page: Voir page : Siehe Seite: **448**

● Naturale Matt Naturelle Matt **R10**

Rettificate in un unico calibro Rectified version in a single caliber Rectifiés en un unique calibre Boden Sie in einem einzigen Kaliber

Caratteristiche tecniche e imballi a pagina: Technical features and packing on page: Caractéristiques techniques et emballages à la page: Technische Eigenschaften und Verpackungen auf Seite: **440**



beton sand cm 75,5x151 - 29<sup>3</sup>/<sub>4</sub>"x59<sup>1</sup>/<sub>2</sub>"

## PEZZI SPECIALI TRIMS ACCESSOIRES FORMSTÜCKE

**Battiscopa Bullnose**  
Plinthe à bord arrondi  
Stehsockel  
cm 7x75,5 - 2<sup>3</sup>/<sub>4</sub>"x29<sup>3</sup>/<sub>4</sub>"  
cm 7x60 - 2<sup>3</sup>/<sub>4</sub>"x23<sup>5</sup>/<sub>8</sub>"



**Gradino Step tread**  
Nez de marche Stufenplatte  
cm 37,5x75,5 - 14<sup>3</sup>/<sub>4</sub>"x29<sup>3</sup>/<sub>4</sub>"  
cm 30x60 - 11<sup>3</sup>/<sub>4</sub>"x23<sup>5</sup>/<sub>8</sub>"

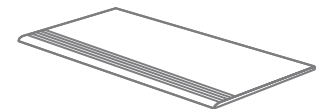

**Gradone (assemblato)**  
cm 75,5x33 - 29<sup>3</sup>/<sub>4</sub>"x13"

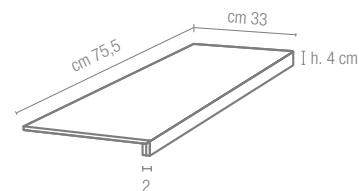

**Angolare (assemblato)**  
cm 75,5x33 - 29<sup>3</sup>/<sub>4</sub>"x13"

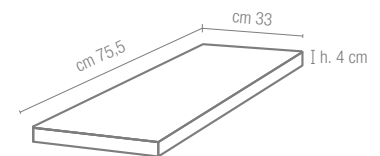

# beton

GRANITOKER



beton pearl cm 75,5x151 - 29<sup>3</sup>/<sub>4</sub>"x59<sup>1</sup>/<sub>2</sub>"

## DECORI DECORS DÉCORS DEKORE

mosaico 6x6\*



cm 30x30 - 11<sup>3</sup>/<sub>4</sub>"x11<sup>3</sup>/<sub>4</sub>"  
 tessera cm 6x6 - 2<sup>3</sup>/<sub>8</sub>"x2<sup>3</sup>/<sub>8</sub>"  
 su rete on net sur trame auf Netz

mosaico tessuto

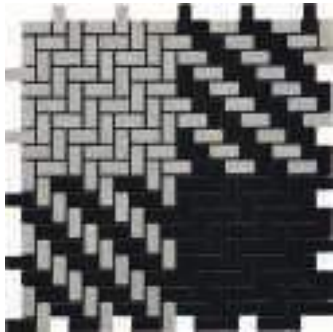

cm 25,1x25,1 - 9<sup>7</sup>/<sub>8</sub>"x9<sup>7</sup>/<sub>8</sub>"  
 1. pearl+dark - 2. mud+ivory

affresco\*



cm 75,5x151 - 29<sup>3</sup>/<sub>4</sub>"x59<sup>1</sup>/<sub>2</sub>"  
 decorato a mano hand decorated décoré à la main Handbemalt

\* Disponibile in tutti i colori della serie Available in all the colours of the series Disponible dans tous les couleurs de la série Verfügbar in allen farben



# beton

GRANITOKER

affresco beton sand cm 75,5x151 - 29<sup>3</sup>/<sub>4</sub>"x59<sup>1</sup>/<sub>2</sub>", beton sand cm 75,5x151 - 29<sup>3</sup>/<sub>4</sub>"x59<sup>1</sup>/<sub>2</sub>"  
beton pearl cm 75,5x151 - 29<sup>3</sup>/<sub>4</sub>"x59<sup>1</sup>/<sub>2</sub>"

**cemento** rasato antracite

# cemento

GRANITOKER



rasato antracite cm 60x120 - 23<sup>5</sup>/<sub>8</sub>"x47<sup>1</sup>/<sub>4</sub>"

## COLORI COLOURS COULEURS FARBEN

cassero antracite



cassero grigio



cassero beige



rasato antracite

rasato grigio

rasato beige

# cemento

GRANITOKER

**cassero bianco**

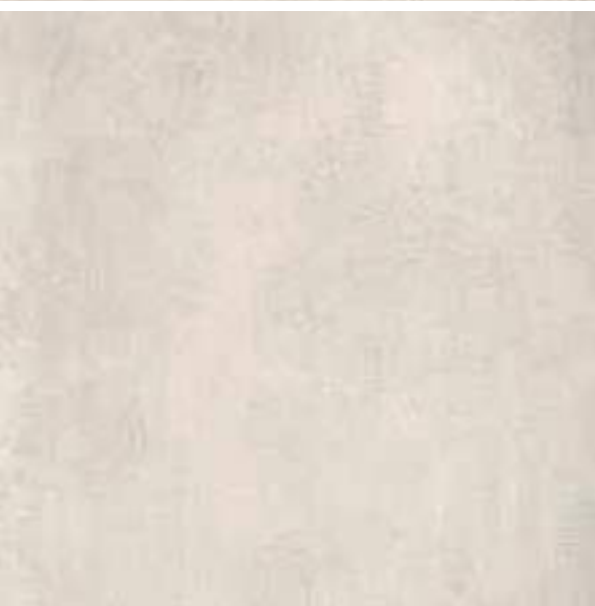











**rasato bianco**



**rasato grigio** cm 60x60 - 23<sup>5</sup>/<sub>8</sub>"x23<sup>5</sup>/<sub>8</sub>",  
**cassero grigio** cm 60x120 - 23<sup>5</sup>/<sub>8</sub>"x47<sup>1</sup>/<sub>4</sub>"

## FORMATI SIZES FORMATS FORMATE

					
Formati Sizes Formats Formate	<b>cm 30x60</b> 11 <sup>3</sup> / <sub>4</sub> "x23 <sup>5</sup> / <sub>8</sub> "	<b>cm 60x60</b> 23 <sup>5</sup> / <sub>8</sub> "x23 <sup>5</sup> / <sub>8</sub> "	<b>cm 37,5x75,5</b> 14 <sup>3</sup> / <sub>4</sub> "x29 <sup>3</sup> / <sub>4</sub> "	<b>cm 75,5x75,5</b> 29 <sup>3</sup> / <sub>4</sub> "x29 <sup>3</sup> / <sub>4</sub> "	<b>cm 60x120</b> 23 <sup>5</sup> / <sub>8</sub> "x47 <sup>1</sup> / <sub>4</sub> "
Superfici Surfaces Surfaces Oberflächen					
	mm 10 mm 9 mm 9*	mm 10	mm 10 mm 9	mm 10	mm 10



Media  
Medium  
Modérée  
Mittlere

Vedi pagina: See page: Voir page : Siehe Seite: **448**

 Cassero **R10**  
 Cassero  
 Rasato **R9**

Rettificate in un unico calibro Rectified version in a single caliber Rectifiés en un unique calibre Boden Sie in einem einzigen Kaliber

\* Non rettificato Unrectified Non rectifié Nicht kalibriert

Caratteristiche tecniche e imballi a pagina: Technical features and packing on page: Caractéristiques techniques et emballages à la page: Technische Eigenschaften und Verpackungen auf Seite: **440**



rasato grigio, cassero grigio cm 60x120 - 23<sup>5</sup>/<sub>8</sub>"x47<sup>1</sup>/<sub>4</sub>"  
 listelli cemento grigio cm 30x30 - 11<sup>3</sup>/<sub>4</sub>"x11<sup>3</sup>/<sub>4</sub>"

K Grandi Lastre K<sub>ontinua</sub>  
 K<sub>ontinua</sub> Big Slabs  
 Grandes Dalles K<sub>ontinua</sub>  
 K<sub>ontinua</sub> große Platten

# cemento

GRANITOKER

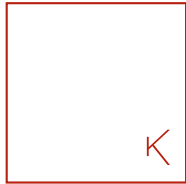

**cm 120x120**  
 47<sup>1</sup>/<sub>4</sub>"x47<sup>1</sup>/<sub>4</sub>"



mm 6,5  
 mm 10

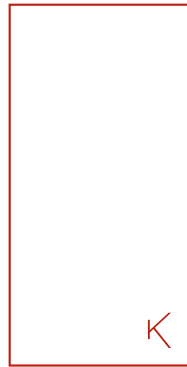

**cm 120x240**  
 47<sup>1</sup>/<sub>4</sub>"x94<sup>1</sup>/<sub>2</sub>"



mm 6,5

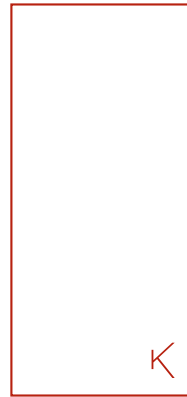

**cm 120x260**  
 47<sup>1</sup>/<sub>4</sub>"x102<sup>3</sup>/<sub>8</sub>"



mm 6,5

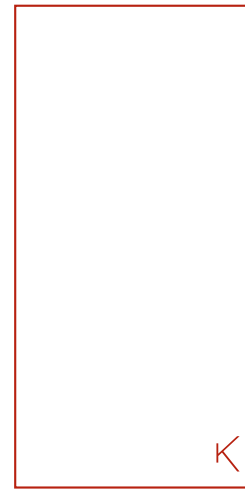

**cm 160x320 \***  
 63"x126"



mm 12

\* Non rettificato Unrectified Non rectifié Nicht kalibriert  
 \*\* Superficie non strutturata Untextured surface Surface non structurée Nicht-strukturierte Oberfläche

## PEZZI SPECIALI TRIMS ACCESSOIRES FORMSTÜCKE

**Battiscopa Bullnose**  
**Plinthe à bord arrondi**  
**Stehsockel**  
 cm 9x60 - 3<sup>1</sup>/<sub>2</sub>"x23<sup>5</sup>/<sub>8</sub>"  
 cm 7x75,5 - 2<sup>3</sup>/<sub>4</sub>"x29<sup>3</sup>/<sub>4</sub>"



**Gradino Step tread**  
**Nez de marche Stufenplatte**  
 cm 30x60 - 11<sup>3</sup>/<sub>4</sub>"x23<sup>5</sup>/<sub>8</sub>"  
 cm 30x120 - 11<sup>3</sup>/<sub>4</sub>"x47<sup>1</sup>/<sub>4</sub>"

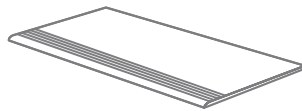

**Gradone (assemblato)**  
 cm 60x33 - 23<sup>5</sup>/<sub>8</sub>"x13"  
 cm 120x33 - 47<sup>1</sup>/<sub>4</sub>"x13"

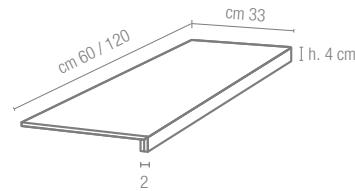

**Angolare (assemblato)**  
 cm 60x33 - 23<sup>5</sup>/<sub>8</sub>"x13"  
 cm 120x33 - 47<sup>1</sup>/<sub>4</sub>"x13"

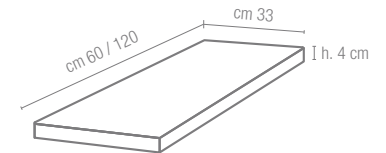

## DECORI DECORS DÉCORS DEKORE

## listelli cemento\*



**cm 30x30** - 11<sup>3</sup>/<sub>4</sub>"x11<sup>3</sup>/<sub>4</sub>"

listello **cm 1,4x30** - 1/2"x11<sup>3</sup>/<sub>4</sub>"  
*su rete on net sur trame auf Netz*

Solo superficie cassero Cassero surface only  
 Seulement surface cassero  
 Nur in der "Cassero" Oberfläche

## mosaico cemento\*



**cm 30x30** - 11<sup>3</sup>/<sub>4</sub>"x11<sup>3</sup>/<sub>4</sub>"

tessera **cm 5,7x2,5** - 2<sup>1</sup>/<sub>4</sub>"x1"  
*su rete on net sur trame auf Netz*

Solo superficie cassero Cassero surface only  
 Seulement surface cassero  
 Nur in der "Cassero" Oberfläche

## mosaico tessuto



**cm 25,1x25,1** - 9<sup>7</sup>/<sub>8</sub>"x9<sup>7</sup>/<sub>8</sub>"

**1. Rasato Antracite + Rasato Grigio**  
**2. Rasato Grigio + Rasato Bianco**  
*su rete on net sur trame auf Netz*

Solo superficie rasato Rasato surface only  
 Seulement surface rasato Nur in der "Rasato" Oberfläche.

## mosaico 6x6\*



**cm 30x30** - 11<sup>3</sup>/<sub>4</sub>"x11<sup>3</sup>/<sub>4</sub>"

tessera **cm 6x6** - 2<sup>3</sup>/<sub>8</sub>"x2<sup>3</sup>/<sub>8</sub>"

Superficie cassero e rasato Cassero and rasato surface  
 Surface cassero et rasato

Nur in der "cassero" und "rasato" Oberfläche.

▽ mm 10    ▽ K<sub>ontinua</sub> mm 6,5

\* Disponibile in tutti i colori della serie Available in all the colours of the series Disponible dans tous les couleurs e la série Verfügbar in allen Farben



# cemento

GRANITOKER

## composizione A\*



**cm 30x60 - 11<sup>3</sup>/<sub>4</sub>"x23<sup>5</sup>/<sub>8</sub>"**  
*su rete on net sur trame auf Netz*

Solo superficie cassero Cassero surface only  
 Seulement surface cassero Nur in der "Cassero" Oberfläche

## rug cemento\*



**cm 60x60 - 23<sup>5</sup>/<sub>8</sub>"x23<sup>5</sup>/<sub>8</sub>"**

Solo superficie rasato Rasato surface only  
 Seulement surface rasato Nur in der "Rasato" Oberfläche

## DECORI DECORS DÉCORS DEKORE

blue falls



cm 120x240 - 47<sup>1</sup>/<sub>4</sub>"x 94<sup>1</sup>/<sub>2</sub>"

—  
▲ KONTINUA mm 6,5

# cemento

GRANITOKER



**cassero grigio** cm 120x240 - 47<sup>1</sup>/<sub>4</sub>"x94<sup>1</sup>/<sub>2</sub>"  
**blue falls** cm 120x240 - 47<sup>1</sup>/<sub>4</sub>"x94<sup>1</sup>/<sub>2</sub>"

resina grey

# resina

GRANITOKER



resina grey cm 90x180 - 35<sup>3</sup>/<sub>8</sub>"x70<sup>7</sup>/<sub>8</sub>"

## COLORI COLOURS COULEURS FARBEN

resina black



resina havana



resina tobacco



resina grey



resina white







# resina

GRANITOKER



**resina black** cm 90x180 - 35<sup>3</sup>/<sub>8</sub>"x70<sup>7</sup>/<sub>8</sub>", cm 45x90 - 17<sup>3</sup>/<sub>4</sub>"x35<sup>3</sup>/<sub>8</sub>" , cm 90x90 - 35<sup>3</sup>/<sub>8</sub>" 35<sup>3</sup>/<sub>8</sub>"

## FORMATI SIZES FORMATS FORMATE

					
<b>Formati Sizes</b> <b>Formats Formate</b>	<b>cm 60x60</b> 23 <sup>5</sup> / <sub>8</sub> "x23 <sup>5</sup> / <sub>8</sub> "	<b>cm 45x90</b> 17 <sup>3</sup> / <sub>4</sub> "x35 <sup>3</sup> / <sub>8</sub> "	<b>cm 90x90</b> 35 <sup>3</sup> / <sub>8</sub> "x35 <sup>3</sup> / <sub>8</sub> "	<b>cm 60x120</b> 23 <sup>5</sup> / <sub>8</sub> "x47 <sup>1</sup> / <sub>4</sub> "	<b>cm 90x180</b> 35 <sup>3</sup> / <sub>8</sub> "x70 <sup>7</sup> / <sub>8</sub> "
<b>Superfici Surfaces</b> <b>Surfaces Oberflächen</b>	●	●	●	●	●
	mm 10	mm 10	mm 10	mm 10	mm 10



Leggera  
Minimal  
Légère  
Leichte

● Naturale Matt Naturelle Matt **R9**

Vedi pagina: See page: Voir page : Siehe Seite: **448**

Rettificate in un unico calibro Rectified version in a single caliber Rectifiés en un unique calibre Boden Sie in einem einzigen Kaliber

Caratteristiche tecniche e imballi a pagina: Technical features and packing on page: Caractéristiques techniques et emballages à la page: Technische Eigenschaften und Verpackungen auf Seite: **440**

## PEZZI SPECIALI TRIMS ACCESSOIRES FORMSTÜCKE

**Battiscopa Bullnose**  
**Plinthe à bord arrondi**  
**Stehsockel**  
cm 9x90 - 3<sup>1</sup>/<sub>2</sub>"x35<sup>3</sup>/<sub>8</sub>"  
cm 9x60 - 3<sup>1</sup>/<sub>2</sub>"x23<sup>5</sup>/<sub>8</sub>"



**Gradino Step tread**  
**Nez de marche Stufenplatte**  
cm 30x90 - 11<sup>3</sup>/<sub>4</sub>"x35<sup>3</sup>/<sub>8</sub>"  
cm 30x60 - 11<sup>3</sup>/<sub>4</sub>"x23<sup>5</sup>/<sub>8</sub>"

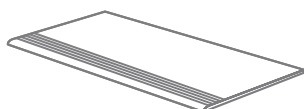

**Gradone (assemblato)**  
cm 120x33 - 47<sup>1</sup>/<sub>4</sub>"x13"  
cm 90x33 - 35<sup>3</sup>/<sub>8</sub>"x13"

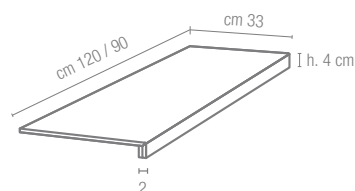

**Angolare (assemblato)**  
cm 120x33 - 47<sup>1</sup>/<sub>4</sub>"x13"  
cm 90x33 - 35<sup>3</sup>/<sub>8</sub>"x13"

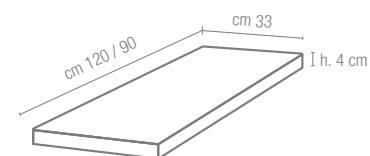



# DECORI DECORS DÉCORS DEKORE

# resina

GRANITOKER

**mosaico 6x6\***

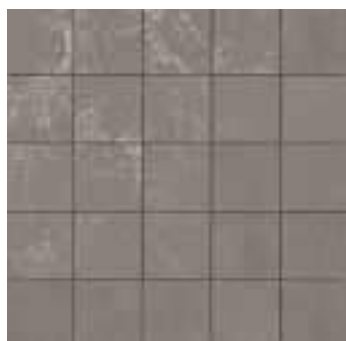

**cm 30x30** - 11<sup>3</sup>/<sub>4</sub>"x11<sup>3</sup>/<sub>4</sub>"  
 tessera **cm 6x6** - 2<sup>3</sup>/<sub>8</sub>"x2<sup>3</sup>/<sub>8</sub>"  
 su rete on net sur trame auf Netz

**mosaico penta**



**cm 31,6x63,2** - 12<sup>1</sup>/<sub>2</sub>"x23<sup>7</sup>/<sub>8</sub>"  
 black + havana + tabacco

**coprispigolo\***



**cm 1,2x45** - 3<sup>3</sup>/<sub>8</sub>"x17<sup>3</sup>/<sub>4</sub>"

\* Disponibile in tutti i colori della serie Available in all the colours of the series Disponible dans tous les couleurs de la série Verfügbar in allen Farben.

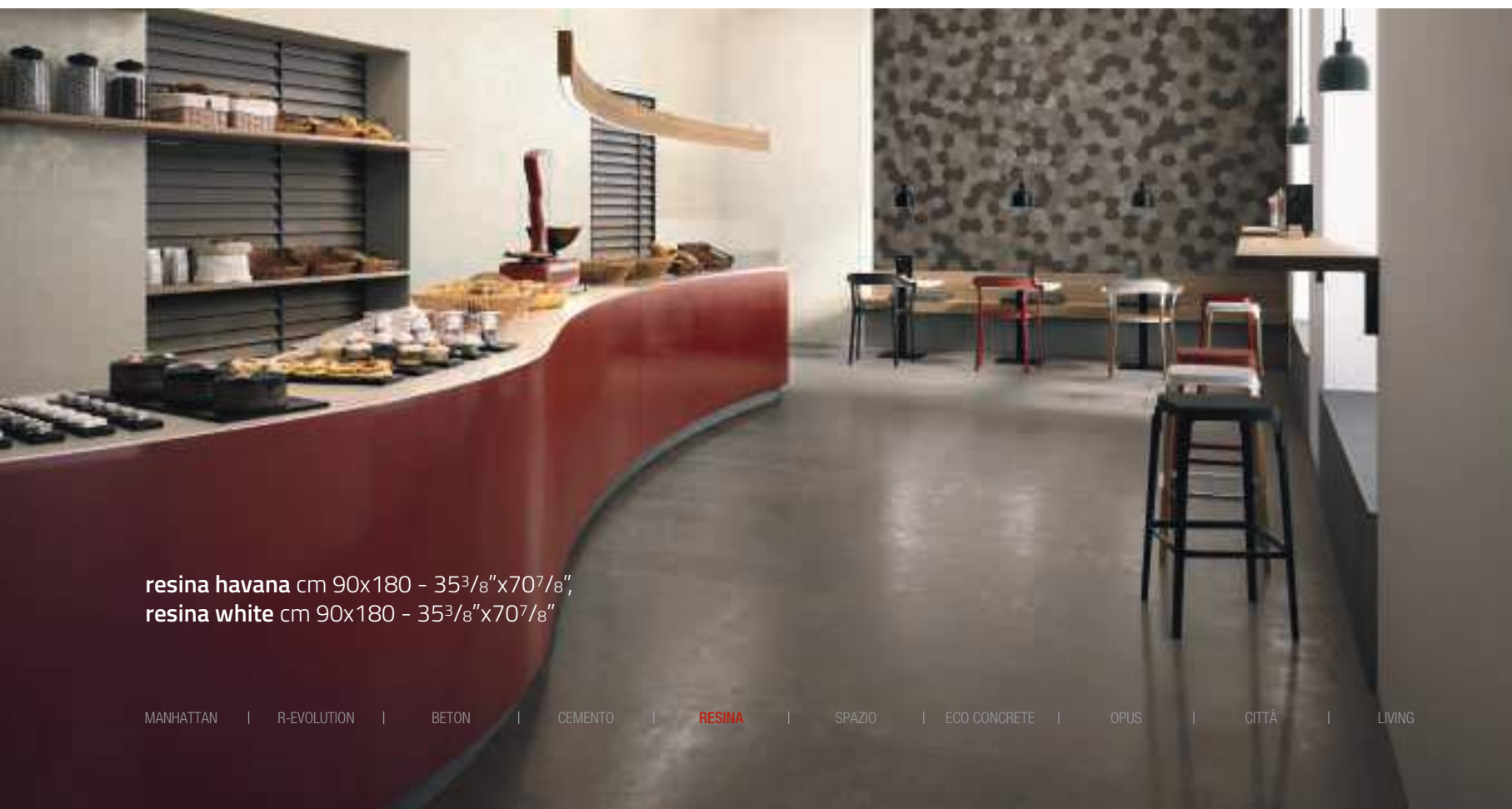

**resina havana** cm 90x180 - 35<sup>3</sup>/<sub>8</sub>"x70<sup>7</sup>/<sub>8</sub>"  
**resina white** cm 90x180 - 35<sup>3</sup>/<sub>8</sub>"x70<sup>7</sup>/<sub>8</sub>"



# spazio

PIETRE NATIVE



**spazio antracite** cm 60x60 - 23<sup>5</sup>/<sub>8</sub>"x23<sup>5</sup>/<sub>8</sub>"

## COLORI COLOURS COULEURS FARBEN

spazio antracite



spazio tabacco



spazio tortora



spazio perla



spazio argento



spazio beige

# spazio

PIETRE NATIVE

spazio grigio





spazio bianco



spazio bianco cm 60x60 - 23<sup>5</sup>/<sub>8</sub>"x23<sup>5</sup>/<sub>8</sub>"

## FORMATI SIZES FORMATS FORMATE

Formati Sizes Formats Formate	<b>cm 30x30</b> 11 <sup>3</sup> / <sub>4</sub> "x11 <sup>3</sup> / <sub>4</sub> "	<b>cm 30x60</b> 11 <sup>3</sup> / <sub>4</sub> "x23 <sup>5</sup> / <sub>8</sub> "	<b>cm 60x60</b> 23 <sup>5</sup> / <sub>8</sub> "x23 <sup>5</sup> / <sub>8</sub> "	<b>cm 37,5x75,5</b> 14 <sup>3</sup> / <sub>4</sub> "x29 <sup>3</sup> / <sub>4</sub> "	<b>cm 75,5x75,5</b> 29 <sup>3</sup> / <sub>4</sub> "x29 <sup>3</sup> / <sub>4</sub> "	<b>cm 75,5x151</b> 29 <sup>3</sup> / <sub>4</sub> "x59 <sup>1</sup> / <sub>2</sub> "
Superfici Surfaces Surfaces Oberflächen	●	●	●	●	●	●
 	mm 9	mm 10 mm 9	mm 10 mm 14*	mm 10 mm 9	mm 10	mm 10



Vedi pagina: See page: Voir page : Siehe Seite: **448**

● Naturale Matt Naturelle Matt **R10**

Rettificate in un unico calibro Rectified version in a single caliber Rectifiés en un unique calibre Boden Sie in einem einzigen Kaliber

\* Solo nei colori: Only in the colours: Seulement dans les couleurs : Nur in die Farben: **Antracite, Argento, Beige, Bianco, Grigio, Tortora, Tabacco**

Caratteristiche tecniche e imballi a pagina: Technical features and packing on page: Caractéristiques techniques et emballages à la page: Technische Eigenschaften und Verpackungen auf Seite: **438**

## PEZZI SPECIALI TRIMS ACCESSOIRES FORMSTÜCKE

**Battiscopa Bullnose**  
**Plinthe à bord arrondi**  
**Stehssockel**  
cm 9x30 - 3<sup>1</sup>/<sub>2</sub>"x11<sup>3</sup>/<sub>4</sub>"  
cm 9x60 - 3<sup>1</sup>/<sub>2</sub>"x23<sup>5</sup>/<sub>8</sub>"  
cm 7x75,5 - 2<sup>3</sup>/<sub>4</sub>"x29<sup>3</sup>/<sub>4</sub>"



**Gradino Step tread**  
**Nez de marche Stufenplatte**  
cm 30x30 - 11<sup>3</sup>/<sub>4</sub>"x11<sup>3</sup>/<sub>4</sub>"  
cm 30x60 - 11<sup>3</sup>/<sub>4</sub>"x23<sup>5</sup>/<sub>8</sub>"

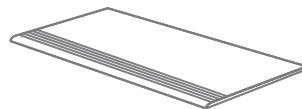

**Gradone (assemblato)**  
cm 60x33 - 23<sup>5</sup>/<sub>8</sub>"x13"

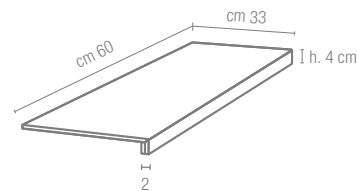

**Angolare (assemblato)**  
cm 60x33 - 23<sup>5</sup>/<sub>8</sub>"x13"

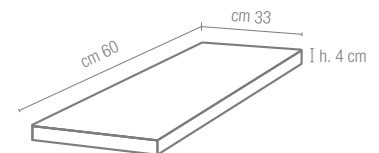

DECORI DECORS DÉCORS DEKORE

**spazio**

PIETRE NATIVE

**mix listelli spazio A**



**cm 30x30 - 11<sup>3</sup>/<sub>4</sub>"x11<sup>3</sup>/<sub>4</sub>"**  
listello **cm 1,4x30 - 1/2"x11<sup>3</sup>/<sub>4</sub>"**  
*su rete on net sur trame auf Netz*  
**bianco, argento, grigio**

**mix listelli spazio B**

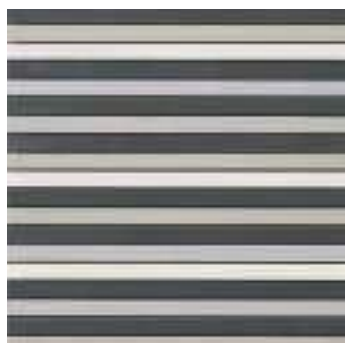

**cm 30x30 - 11<sup>3</sup>/<sub>4</sub>"x11<sup>3</sup>/<sub>4</sub>"**  
listello **cm 1,4x30 - 1/2"x11<sup>3</sup>/<sub>4</sub>"**  
*su rete on net sur trame auf Netz*  
**antracite, grigio, bianco, argento**

**mix listelli spazio C**



**cm 30x30 - 11<sup>3</sup>/<sub>4</sub>"x11<sup>3</sup>/<sub>4</sub>"**  
listello **cm 1,4x30 - 1/2"x11<sup>3</sup>/<sub>4</sub>"**  
*su rete on net sur trame auf Netz*  
**beige, tortora, perla**

**mosaico 6x6\***



**cm 30x30 - 11<sup>3</sup>/<sub>4</sub>"x11<sup>3</sup>/<sub>4</sub>"**  
tessera **cm 6x6 - 2<sup>3</sup>/<sub>8</sub>"x2<sup>3</sup>/<sub>8</sub>"**  
*su rete on net sur trame auf Netz*

\* Disponibile in tutti i colori della serie  
Available in all the colours of the series  
Disponibile dans tous les couleurs de la série  
Verfügbar in allen Farben

**mix listelli spazio C**

**cm 30x30 - 11<sup>3</sup>/<sub>4</sub>"x11<sup>3</sup>/<sub>4</sub>"**  
**spazio beige cm 30x30 - 11<sup>3</sup>/<sub>4</sub>"x11<sup>3</sup>/<sub>4</sub>" ,**  
**cm 60x60 - 23<sup>5</sup>/<sub>8</sub>"x23<sup>5</sup>/<sub>8</sub>"**





# eco concrete

GRESPLUS



eco grigio cm 60x60 - 23<sup>5</sup>/<sub>8</sub>"x23<sup>5</sup>/<sub>8</sub>"

## COLORI COLOURS COULEURS FARBEN

eco antracite



eco beige



eco bianco

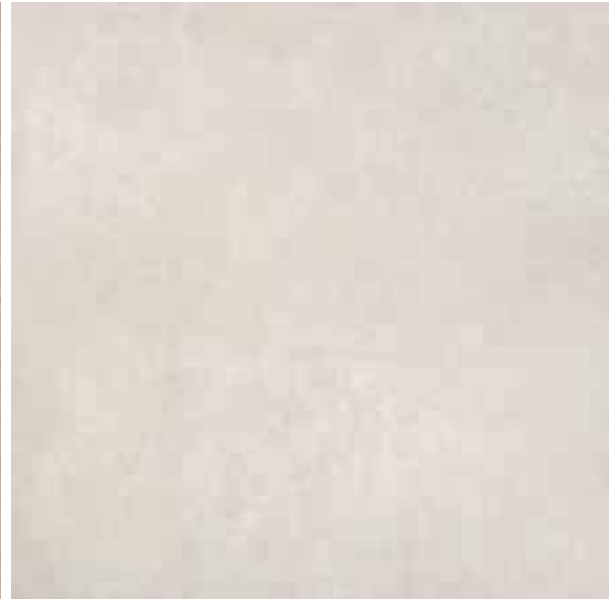

eco cenere







eco grigio

FORMATI SIZES FORMATS FORMATE

# eco concrete

GRESPLUS

				
<b>Formati Sizes</b> <b>Formats Formate</b>	<b>cm 45x45</b> 17 <sup>3</sup> / <sub>4</sub> "x 17 <sup>3</sup> / <sub>4</sub> "	<b>cm 30x60</b> 11 <sup>3</sup> / <sub>4</sub> "x23 <sup>5</sup> / <sub>8</sub> "	<b>cm 60x60</b> 23 <sup>5</sup> / <sub>8</sub> "x23 <sup>5</sup> / <sub>8</sub> "	<b>cm 60x120</b> 23 <sup>5</sup> / <sub>8</sub> "x23 <sup>5</sup> / <sub>8</sub> "
<b>Superfici Surfaces</b> <b>Surfaces Oberflächen</b>	●*	● ●	● ●	●
	mm 8	mm 8	mm 9	mm 9



Media  
Medium  
Modérée  
Mittlere

Vedi pagina: See page: Voir page : Siehe Seite: **448**

Rettificate in un unico calibro Rectified version in a single caliber Rectifiés en un unique calibre Boden Sie in einem einzigen Kaliber

Caratteristiche tecniche e imballi a pagina: Technical features and packing on page: Caractéristiques techniques et emballages à la page: Technische Eigenschaften und Verpackungen auf Seite: **444**

- Naturale Matt Naturelle Matt **R10 A+B**
- \* Soft **R9**  
Non rettificato Unrectified  
Non rectifié Nicht kalibriert
- Grip **R11 A+B**

PEZZI SPECIALI TRIMS ACCESSOIRES FORMSTÜCKE

▲ 2pcs  45°

**Battiscopa Bullnose**  
**Plinthe à bord arrondi**  
**Stehsockel**  
cm 9x60 - 3<sup>1</sup>/<sub>2</sub>"x23<sup>5</sup>/<sub>8</sub>"  
cm 9x45 - 3<sup>1</sup>/<sub>2</sub>"x17<sup>3</sup>/<sub>4</sub>"



**Gradino Step tread**  
**Nez de marche**  
**Stufenplatte**  
cm 30x60 - 11<sup>3</sup>/<sub>4</sub>"x23<sup>5</sup>/<sub>8</sub>"

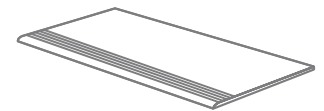

**Art. 9660 Pool Wave**  
cm 60x25 - 23<sup>5</sup>/<sub>8</sub>"x9<sup>7</sup>/<sub>8</sub>"

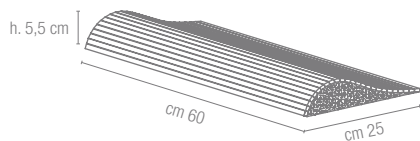

**Art. 9667 Pool Wave ▲**  
cm 25x29 - 9<sup>7</sup>/<sub>8</sub>"x11<sup>1</sup>/<sub>2</sub>"

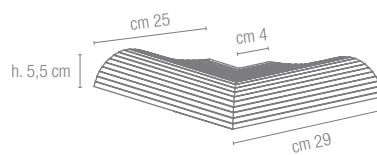

**Art. 9668 Pool Wave ▲**  
cm 25x29 - 9<sup>7</sup>/<sub>8</sub>"x11<sup>1</sup>/<sub>2</sub>"

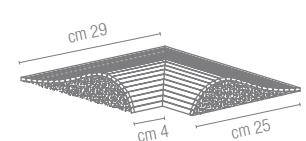

DECORI DECORS DÉCORS DEKORE

**mosaico 6x6\***



**cm 30x30 - 11<sup>3</sup>/<sub>4</sub>"x11<sup>3</sup>/<sub>4</sub>"**  
**tessera cm 6x6 - 2<sup>3</sup>/<sub>8</sub>"x2<sup>3</sup>/<sub>8</sub>"**

\* Su rete. Disponibile in tutti i colori della serie  
On net. Available in all the colours of the series  
Sur trame. Disponible dans tous les couleurs de la série  
Auf Netz. Verfügbar in allen Farben



# opus

GRANITOKER



**opus grigio** cm 20x20 - 7<sup>7</sup>/<sub>8</sub>"x7<sup>7</sup>/<sub>8</sub>", **cementina grigia mix** cm 20x20 - 7<sup>7</sup>/<sub>8</sub>"x7<sup>7</sup>/<sub>8</sub>"

## COLORI COLOURS COULEURS FARBEN

opus beige



opus grigio



# FORMATI SIZES FORMATS FORMATE

**opus**  
GRANITOKER

Formati Sizes  
Formats Formate

□  
**cm 20x20**  
7<sup>7</sup>/<sub>8</sub>"x7<sup>7</sup>/<sub>8</sub>"

Superfici Surfaces  
Surfaces Oberflächen

●



mm 9



Accentuata  
Accentuated  
Importante  
Starke

● Naturale Matt Naturelle Matt **R9**

Vedi pagina: See page: Voir page : Siehe Seite: **448**

Caratteristiche tecniche e imballi a pagina: Technical features and packing on page: Caractéristiques techniques et emballages à la page: Technische Eigenschaften und Verpackungen auf Seite: **440**

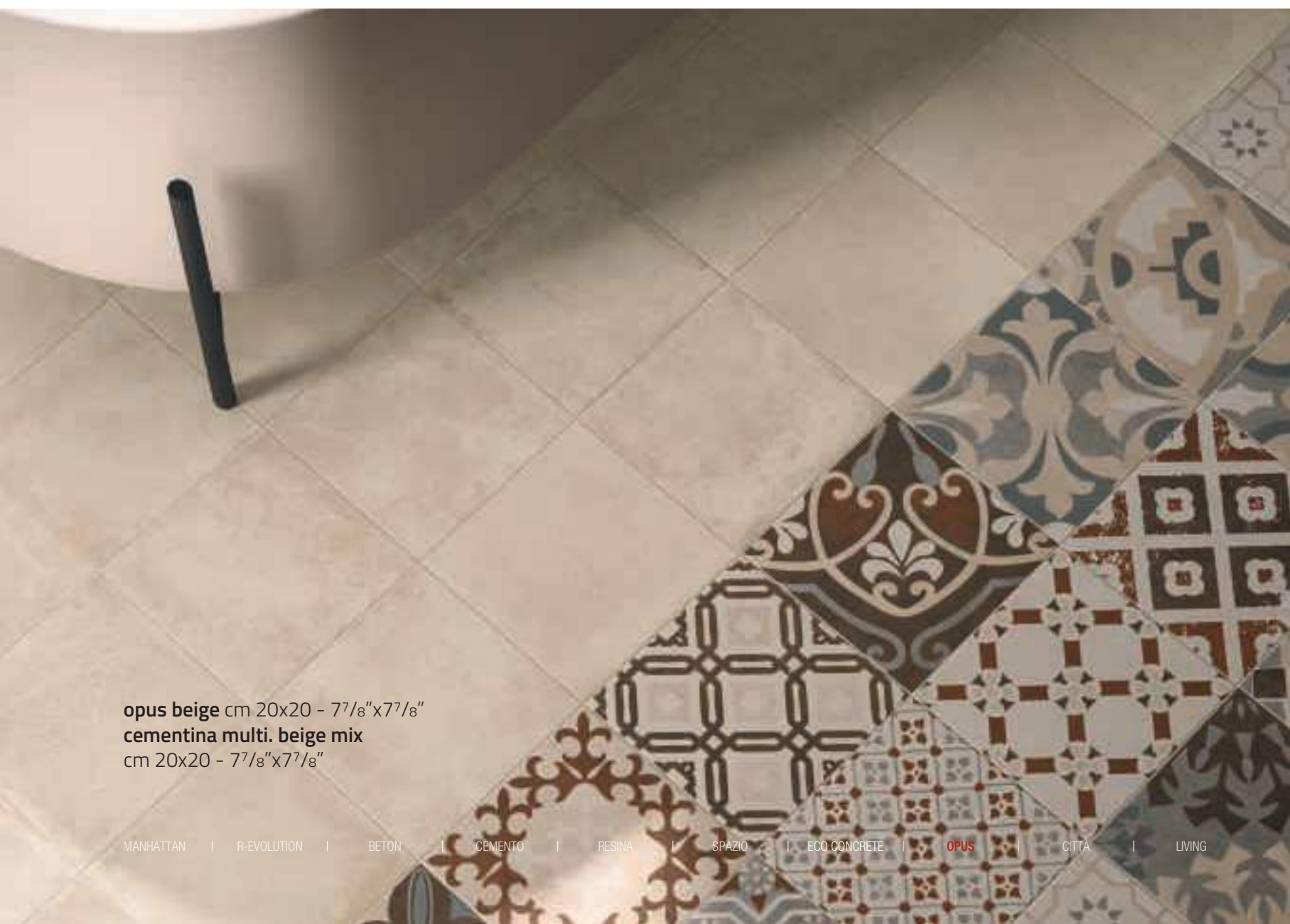

**opus beige** cm 20x20 - 7<sup>7</sup>/<sub>8</sub>"x7<sup>7</sup>/<sub>8</sub>"  
**cementina multi. beige mix**  
cm 20x20 - 7<sup>7</sup>/<sub>8</sub>"x7<sup>7</sup>/<sub>8</sub>"

# DECORI DECORS DÉCORS DEKORE

**cementina multi. beige A\***



cm 20x20 - 7<sup>7</sup>/<sub>8</sub>"x7<sup>7</sup>/<sub>8</sub>"

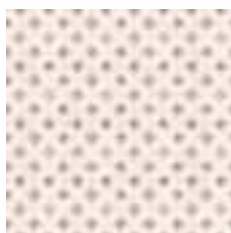

**cementina multi. beige B\***



cm 20x20 - 7<sup>7</sup>/<sub>8</sub>"x7<sup>7</sup>/<sub>8</sub>"



**cementina multi. beige C\***

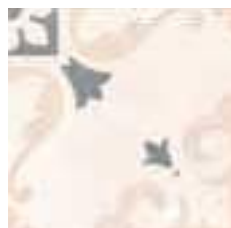

cm 20x20 - 7<sup>7</sup>/<sub>8</sub>"x7<sup>7</sup>/<sub>8</sub>"



**cementina multi. beige D\***



cm 20x20 - 7<sup>7</sup>/<sub>8</sub>"x7<sup>7</sup>/<sub>8</sub>"



**cementina multi. beige mix\*\***

cm 20x20 - 7<sup>7</sup>/<sub>8</sub>"x7<sup>7</sup>/<sub>8</sub>"



\* Ordinabili singolarmente (minimo 1 scatola) Option to choose specific designs (min. one box) Possibilité de commande séparée (1 boîte minimum) Einzeln bestellbar (mindestens 1 Karton)

\*\* Non ordinabili singolarmente (ogni scatola contiene un mix di soggetti diversi) Specific designs not available (each box contains a mix of different designs)  
Pas de possibilité de commande séparée (chaque boîte contient un mélange de décors différents) Nicht einzeln bestellbar (jeder Karton enthält eine Mischung unterschiedlicher Elemente)



# opus

GRANITOKER

cementina multi. beige mix cm 20x20 - 7<sup>7</sup>/<sub>8</sub>"x7<sup>7</sup>/<sub>8</sub>"

## DECORI DECORS DÉCORS DEKORE

cementina  
multi. grigia A\*cm 20x20 - 7<sup>7</sup>/<sub>8</sub>"x7<sup>7</sup>/<sub>8</sub>"cementina  
multi. grigia B\*cm 20x20 - 7<sup>7</sup>/<sub>8</sub>"x7<sup>7</sup>/<sub>8</sub>"cementina  
multi. grigia C\*cm 20x20 - 7<sup>7</sup>/<sub>8</sub>"x7<sup>7</sup>/<sub>8</sub>"cementina  
multi. grigia D\*cm 20x20 - 7<sup>7</sup>/<sub>8</sub>"x7<sup>7</sup>/<sub>8</sub>"

cementina multi. grigia mix\*\*

cm 20x20 - 7<sup>7</sup>/<sub>8</sub>"x7<sup>7</sup>/<sub>8</sub>"

\* Ordinabili singolarmente (minimo 1 scatola) Option to choose specific designs (min. one box) Possibilité de commande séparée (1 boîte minimum) Einzeln bestellbar (mindestens 1 Karton)

\*\* Non ordinabili singolarmente (ogni scatola contiene un mix di soggetti diversi) Specific designs not available (each box contains a mix of different designs)

Pas de possibilité de commande séparée (chaque boîte contient un mélange de décors différents) Nicht einzeln bestellbar (jeder Karton enthält eine Mischung unterschiedlicher Elemente)

# opus

GRANITOKER



opus grigio cm 20x20 - 7<sup>7</sup>/<sub>8</sub>"x7<sup>7</sup>/<sub>8</sub>", cementina multi. grigia mix cm 20x20 - 7<sup>7</sup>/<sub>8</sub>"x7<sup>7</sup>/<sub>8</sub>"

## DECORI DECORS DÉCORS DEKORE

cementina grigia mix\*

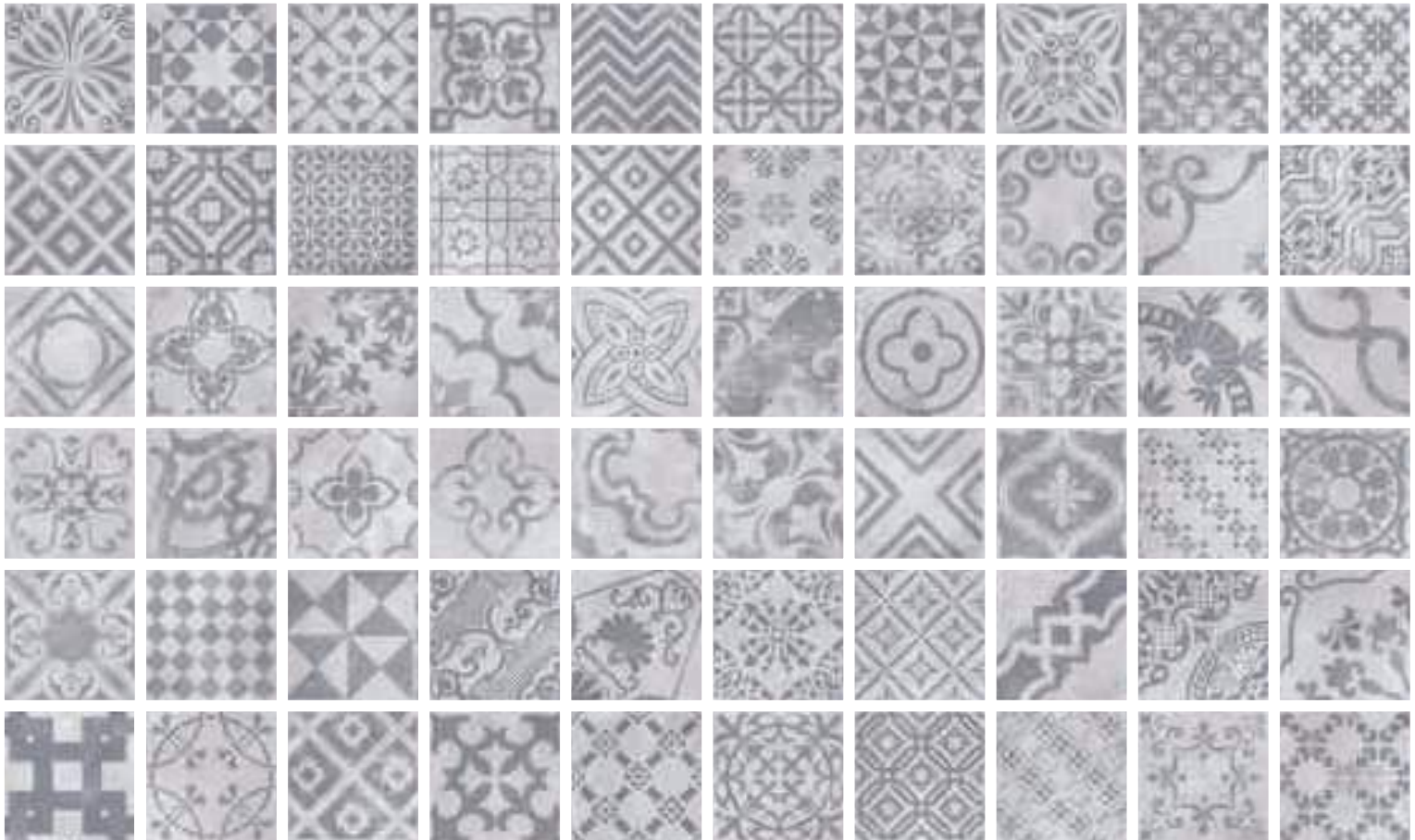
cm 20x20 - 7<sup>7</sup>/<sub>8</sub>"x7<sup>7</sup>/<sub>8</sub>"

\* Non ordinabili singolarmente (ogni scatola contiene un mix di soggetti diversi) Specific designs not available (each box contains a mix of different designs)

Pas de possibilité de commande séparée (chaque boîte contient un mélange de décors différents) Nicht einzeln bestellbar (jeder Karton enthält eine Mischung unterschiedlicher Elemente)

# opus

GRANITOKER



opus grigio cm 20x20 - 77/8"x77/8", cementina grigia mix cm 20x20 - 77/8"x77/8"



# città

GRESPLUS



**berlino, stoccolma. mosca** cm 30x60 - 11<sup>3</sup>/<sub>4</sub>"x23<sup>5</sup>/<sub>8</sub>"

## COLORI COLOURS COULEURS FARBEN

berlino



stoccolma



mosca



londra



atene



lisbona



## FORMATI SIZES FORMATS FORMATE

**città**  
GRESPLUS

praga



Formati Sizes Formats Formate	<b>cm 45x45</b> 17 <sup>3</sup> / <sub>4</sub> "x 17 <sup>3</sup> / <sub>4</sub> "	<b>cm 30x60</b> 11 <sup>3</sup> / <sub>4</sub> "x23 <sup>5</sup> / <sub>8</sub> "	<b>cm 60x60</b> 23 <sup>5</sup> / <sub>8</sub> "x23 <sup>5</sup> / <sub>8</sub> "
Superfici Surfaces Surfaces Oberflächen	●	●	●
	mm 8*	mm 8 mm 8*	mm 9



Media  
Medium  
Modérée  
Mittlere

● Naturale Matt Naturelle Matt

Vedi pagina: See page: Voir page : Siehe Seite: **448**

Rettificate in un unico calibro Rectified version in a single caliber  
Rectifiés en un unique calibre Boden Sie in einem einzigen Kaliber

\* Non rettificato Unrectified Non rectifié Nicht kalibriert

Caratteristiche tecniche e imballi a pagina: Technical features and packing on page:  
Caractéristiques techniques et emballages à la page Technische: Eigenschaften und Verpackungen auf Seite: **444**

## PEZZI SPECIALI TRIMS ACCESSOIRES FORMSTÜCKE

**Battiscopa Bullnose**  
**Plinthe à bord arrondi**  
**Stehsockel**  
cm 9x45 - 3<sup>1</sup>/<sub>2</sub>"x17<sup>3</sup>/<sub>4</sub>"  
cm 9x60 - 3<sup>1</sup>/<sub>2</sub>"x23<sup>5</sup>/<sub>8</sub>"



**Gradino Step tread**  
**Nez de marche**  
**Stufenplatte**  
cm 30x60 - 11<sup>3</sup>/<sub>4</sub>"x23<sup>5</sup>/<sub>8</sub>"

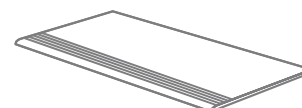



# living

ECOGRES



living noisette cm 33x33 - 13"x13"

## COLORI COLOURS COULEURS FARBEN

living black



living grey



living white



living noisette







living beige



living ice

## FORMATI SIZES FORMATS FORMATE

**living**  
ECOGRES

Formati Sizes Formats Formate	 <b>cm 33x33</b> 13"x13"	 <b>cm 41,5x41,5</b> 16 <sup>3</sup> / <sub>8</sub> "x16 <sup>3</sup> / <sub>8</sub> "	 <b>cm 30x60</b> 1 <sup>3</sup> / <sub>4</sub> "x23 <sup>5</sup> / <sub>8</sub> "
Living Black G3*	●	●	●
Living Grey G4*	●	●	●
Living Noisette G4*	●	●	●
Living Beige G4*	●	●	●
Living Ice G4*	●	●	●
Living White G4*	●	●	●
	mm 8	mm 8	mm 8

\* Vedi pagina: See page: Voir page : Siehe Seite: **447**

● Naturale Matt Naturelle Matt **R9**

Nel caso di combinazioni di formati di spessori diversi, specificarlo espressamente nell'ordine  
Please specify in your order if you wish to purchase formats including more than one thickness  
Prière de spécifier dans votre commande si vous souhaitez acheter des formats avec différentes épaisseurs  
Bitte weisen Sie im Bestellungsformular ausdrücklich darauf hin, wenn Sie Formatkombinationen mit verschiedenen Stärken wünschen

Caratteristiche tecniche e imballi a pagina: Technical features and packing on page:  
Caractéristiques techniques et emballages à la page: Technische Eigenschaften und Verpackungen auf Seite: **446**

## PEZZI SPECIALI TRIMS ACCESSOIRES FORMSTÜCKE

**Battiscopa Bullnose**  
**Plinthe à bord arrondi Stehsockel**  
cm 8x33 - 3<sup>1</sup>/<sub>2</sub>"x13"  
cm 8x41,5 - 3<sup>1</sup>/<sub>2</sub>"x16<sup>3</sup>/<sub>8</sub>"  
cm 9x60 - 3<sup>1</sup>/<sub>2</sub>"x23<sup>5</sup>/<sub>8</sub>"



**Gradino Step tread**  
**Nez de marche Stufenplatte**  
cm 30x60 - 11<sup>3</sup>/<sub>4</sub>"x23<sup>5</sup>/<sub>8</sub>"

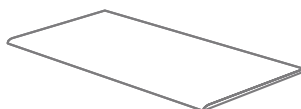

**Gradino Step tread**  
**Nez de marche Stufenplatte**  
cm 33x33 - 13"x13"

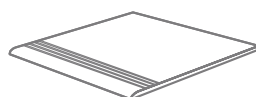

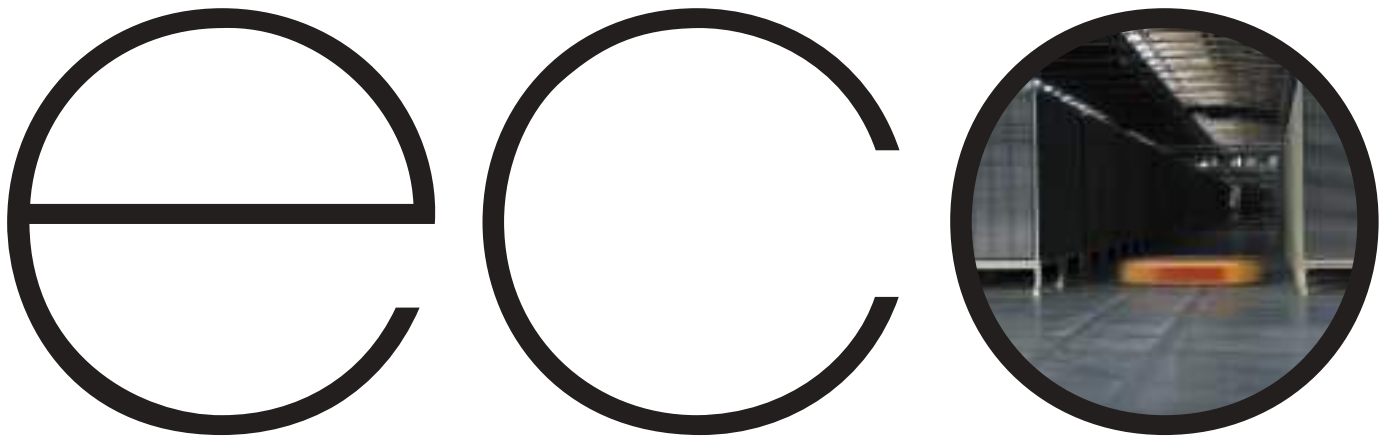

ecotechnique écotechnique ökotechnik

**tecnico**

ecot**tecnico**

416 **technic**

426 **tactile**



**TECNICO**

Materiale, prodotto, componente dotato di proprietà e caratteristiche prestazionali individuate o definite in rapporto alla sua origine e all'impiego a cui è destinato, che ne determinano il livello e il conseguente grado di specializzazione. Le proprietà e le caratteristiche sono valutabili secondo unità di misura, grandezze, capacità e procedure di prova rilevabili attraverso specifiche unanimemente condivise.

**TECHNICAL**

Material, product or component possessing properties and performance specifications identified or defined depending on their origin and the use for which they have been designed, and that determine their level and consequent degree of specialisation. The properties and characteristics can be evaluated according to units of measurement, magnitudes, capacities and test procedures established by universally accepted specifications.





# technic

GRANITOGRES



nebraska cm 20x20 - 77/8"x77/8"

## COLORI COLOURS COULEURS FARBEN

grigio cenere



bianco avorio



bianco B



nebraska



arkansas



ontario

Pavimenti  
Floors  
Revêtement sol  
Bodenfliesen

Caratteristiche tecniche ed estetiche a pagina: Technical and aesthetics features on page:  
Caractéristiques techniques et esthétiques à la page : Technische und ästhetische Eigenschaften auf Seite: **434**

# technic

GRANITOGRES

Landscape tundra 100 satin lucida

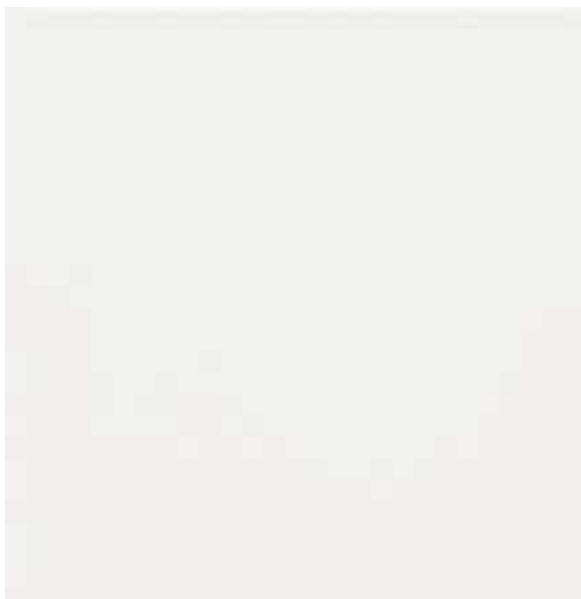

Landscape beach 101 satin



bianco b *secura* cm 20x20 - 7<sup>7</sup>/<sub>8</sub>"x7<sup>7</sup>/<sub>8</sub>"

Rivestimenti smaltati  
 Glazed tiles  
 Revêtement émaillé  
 Fliesen aus glasiertem Feinsteinzeug

## COLORI COLOURS COULEURS FARBEN

technic R10



roccia R12 (A+B+C)



profil R12 - V8 (A+B+C)



reticolo R12 - V4 (A+B+C)

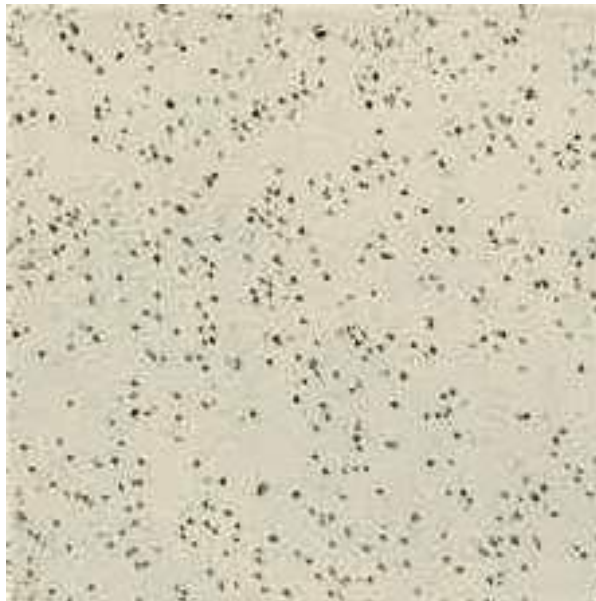

carbo R12



sicura R11 (A+B)

# technic

GRANITOGRES

bugnato R11 - V6 (A+B+C)

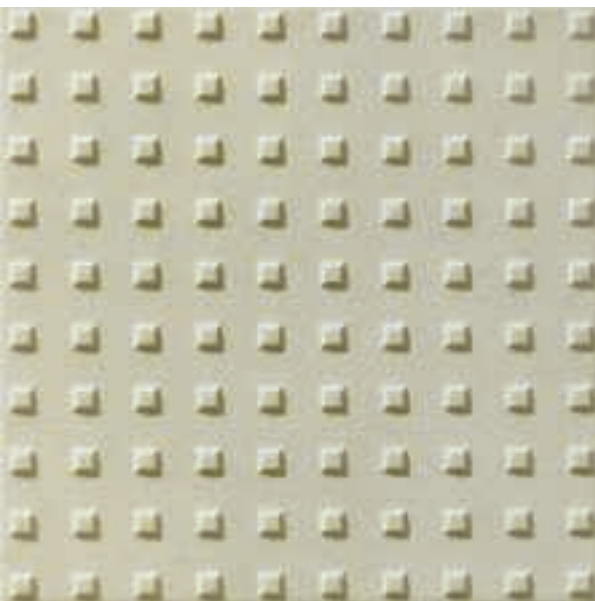













































pavè R11 - V4 (A+B+C)



safe R13 (A+B+C)

## FORMATI SIZES FORMATS FORMATE

GRES PORCELLANATO NON SMALTATO UNGLAZED PORCELAIN STONEWARE GRÉS CÉRAME NON ÉMAILLÉ UNGLASIERTE FEINSTEINZEUGFLIESEN

Formati Sizes Formats Formate	 cm 20x20 7 <sup>7</sup> / <sub>8</sub> "x7 <sup>7</sup> / <sub>8</sub> "	 cm 20x20 7 <sup>7</sup> / <sub>8</sub> "x7 <sup>7</sup> / <sub>8</sub> "	 cm 20x20 7 <sup>7</sup> / <sub>8</sub> "x7 <sup>7</sup> / <sub>8</sub> "	 cm 12,5x25 11 <sup>3</sup> / <sub>4</sub> "x11 <sup>3</sup> / <sub>4</sub> "	 cm 30x30 11 <sup>3</sup> / <sub>4</sub> "x11 <sup>3</sup> / <sub>4</sub> "	 cm 30x30 11 <sup>3</sup> / <sub>4</sub> "x11 <sup>3</sup> / <sub>4</sub> "	 cm 30x30 11 <sup>3</sup> / <sub>4</sub> "x11 <sup>3</sup> / <sub>4</sub> "
	mm 8	mm 12	mm 14	mm 8	mm 8	mm 11,2	mm 14
Unicolore Grigio Cenere							
Unicolore Bianco avorio							
Unicolore Bianco B							
Granito 1 Ontario							
Granito 1 Nebraska							
Granito 1 Arkansas							

 Roccia **R12**     Pavé **R11**     Carbo **R12**  
 Bugnato **R11**     Secura **R11**     Reticolo **R12**  
 Profil **R12**     Technic **R10**     Safe **R13**

Caratteristiche tecniche e imballi a pagina: Technical features and packing on page: Caractéristiques techniques et emballages à la page: Technische Eigenschaften und Verpackungen auf Seite: **434**

## PEZZI SPECIALI TRIMS ACCESSOIRES FORMSTÜCKE

**Battiscopa Bullnose**  
Plinthe à bord arrondi  
**Stehsokkel**  
cm 9x30 - 3<sup>1</sup>/<sub>2</sub>"x11<sup>3</sup>/<sub>4</sub>"  
cm 10x20 - 4"x7<sup>7</sup>/<sub>8</sub>"



**Zoccolo a raccordo a taglio retto**  
Cove base - straight top  
**Plinthe à gorge avec bord vif**  
**Hohlkehlsokkel (scharfkantig)**  
cm 10x20 - 4"x7<sup>7</sup>/<sub>8</sub>"

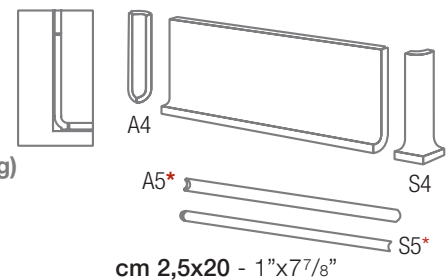

**Gradino Step tread**  
Nez de marche **Stufenplatte**  
cm 30x30 - 11<sup>3</sup>/<sub>4</sub>"x11<sup>3</sup>/<sub>4</sub>"

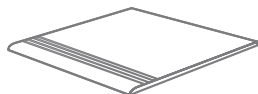

**Sguscezza Cove**  
Gorge Rinnleiste  
cm 4x20 - 1<sup>1</sup>/<sub>2</sub>"x7<sup>7</sup>/<sub>8</sub>"

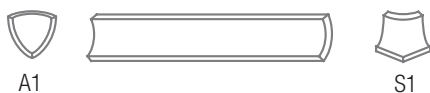

**Zoccolo ad appoggio smussato**  
Sit-on skirting - bevelled top  
**Plinthe à talon avec bord arrondi**  
**Aufsetzsockel mit abgerundeter Kante**  
cm 10x20 - 4"x7<sup>7</sup>/<sub>8</sub>"

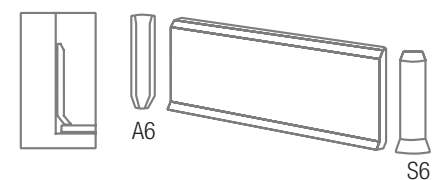

**Angolare Longitudinal angle**  
Angulaire Schenkelplatte  
cm 20x5x5 - 7<sup>7</sup>/<sub>8</sub>"x2"x2"

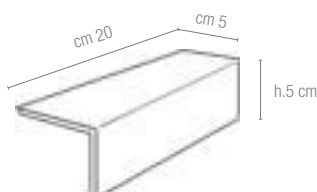



SUPERFICI SURFACES SURFACES OBERFLÄCHEN

**technic**

GRANITOGRES



14 mm

11,2/12 mm

8 mm

## PEZZI SPECIALI **MODULO M 12,5x25** MODULAR TRIMS ACCESSOIRES MODULAIRES MODULAR FORMSTÜCKE

### SISTEMA CANALETTA 1 CHANNEL SYSTEM 1 SYSTEME CANIVEAU 1 RINNESYSTEM 1

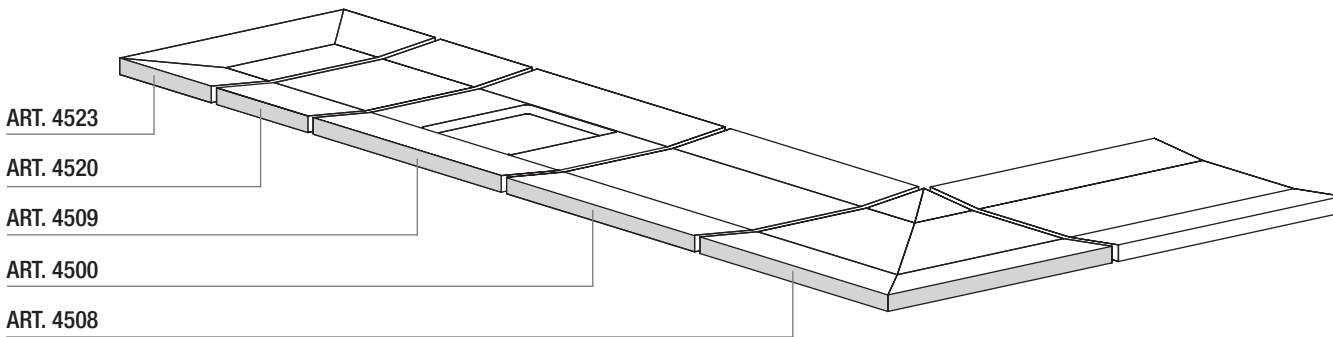

ART. 4523

ART. 4520

ART. 4509

ART. 4500

ART. 4508

ART. 4523

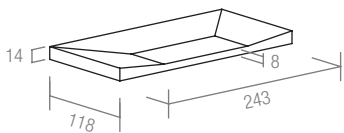

ART. 4520

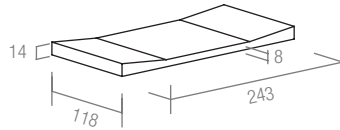

ART. 4509

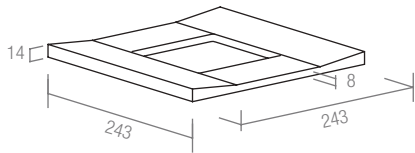

ART. 4500

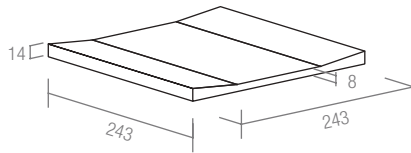

ART. 4508

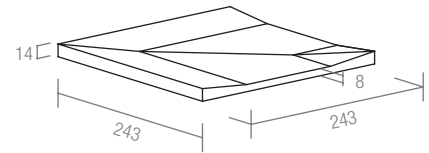

Produzione nei colori:  
Currently produced  
in the following  
colours:  
Production dans  
les couleurs :  
Lieferbar in den  
Farben:  
**Bianco Avorio,**  
**Bianco B**  
Superficie: Surface:  
Surface : Oberfläche:  
**grip**

### SISTEMA CANALETTA 2 CHANNEL SYSTEM 2 SYSTEME CANIVEAU 2 RINNESYSTEM 2

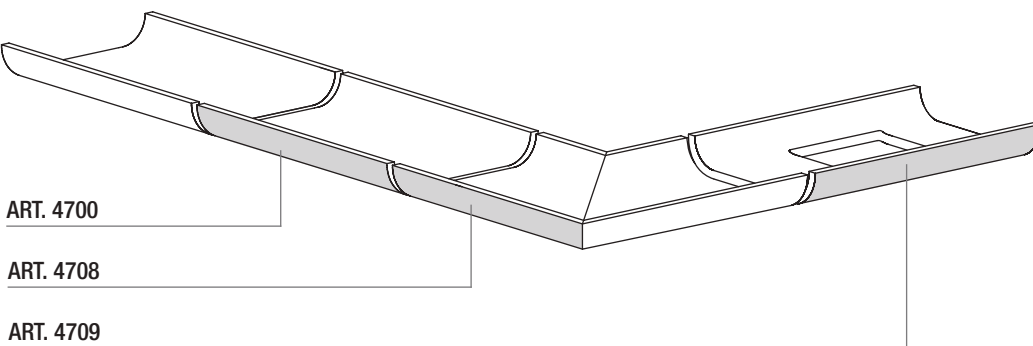

ART. 4700

ART. 4708

ART. 4709

ART. 4700

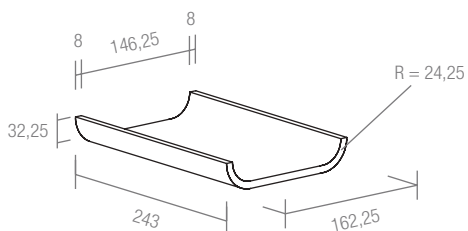

ART. 4708

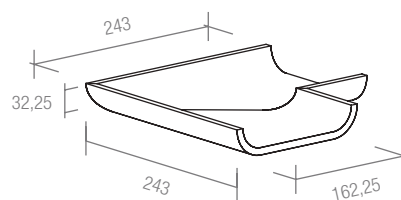

ART. 4709

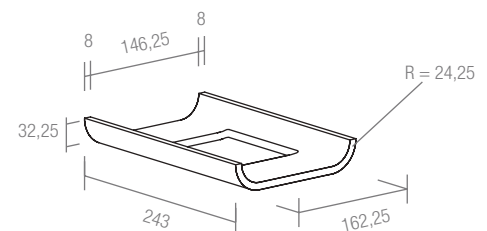

Produzione nei colori:  
Currently produced  
in the following  
colours:  
Production dans  
les couleurs :  
Lieferbar in den  
Farben:  
**Tundra 100**  
Superficie: Surface:  
Surface : Oberfläche:  
**satın**

# technic

## GRANITOGRES

### SISTEMA BECCO DI CIVETTA BULLNOSE SYSTEM SYSTEME BORD ARRONDI STEH SOCKELSYSTEM

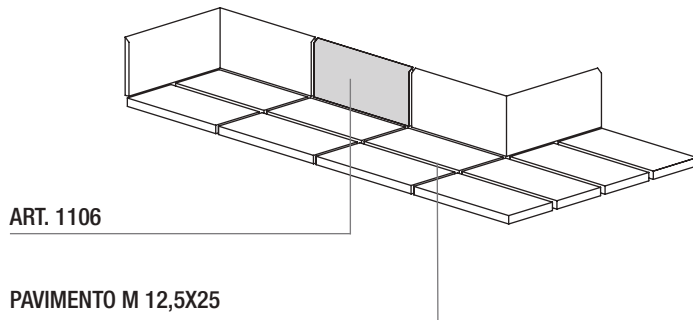

ART. 1106

PAVIMENTO M 12,5X25

Produzione nei colori:  
Currently produced in the following colours:  
Production dans les couleurs :  
Lieferbar in den Farben:  
**Bianco Avorio, Bianco B**  
Superficie: Surface: Surface : Oberfläche: **matt**  
**Tundra 100, Beach 101**  
Superficie: Surface: Surface : Oberfläche: **satin**

ART. 1106

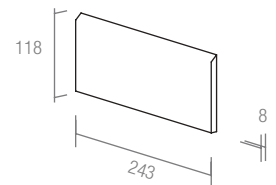

### SISTEMA ZOCCOLO A RACCORDO SMUSSATO COVE BASE SYSTEM WITH BEVELLED TOP SYSTEME PLINTHE A GORGE BISEAUTE HOHKEHL SOCKELSYSTEM MIT ABGERUNDETER KANTE

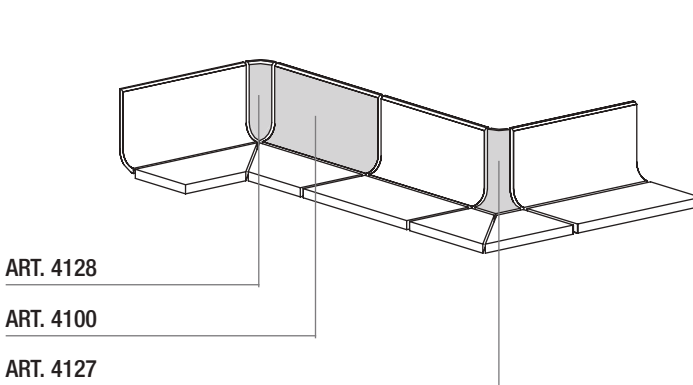

ART. 4128

ART. 4100

ART. 4127

ART. 4127

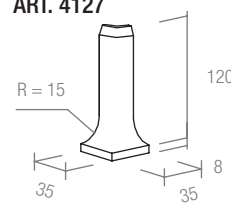

ART. 4128

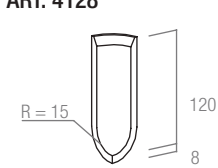

Produzione nei colori:  
Currently produced in the following colours:  
Production dans les couleurs :  
Lieferbar in den Farben:  
**Bianco Avorio, Bianco B**  
Superficie: Surface: Surface : Oberfläche: **matt**  
**Tundra 100, Beach 101**  
Superficie: Surface: Surface : Oberfläche: **satin**

ART. 4100

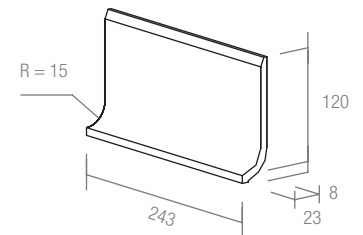

### SISTEMA SGUSCETTA COVE SYSTEM SYSTEME GORGE RINNENLEISTESYSTEM

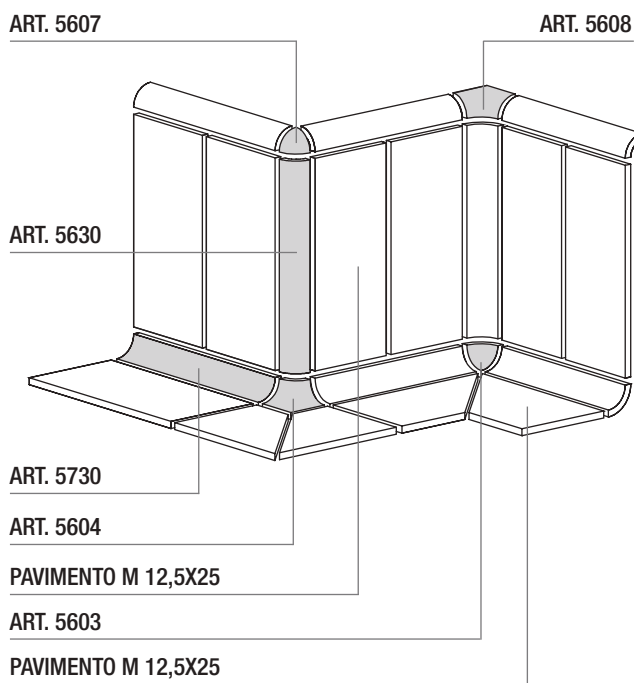

ART. 5607

ART. 5608

ART. 5630

ART. 5730

ART. 5604

PAVIMENTO M 12,5X25

ART. 5603

PAVIMENTO M 12,5X25

ART. 5630

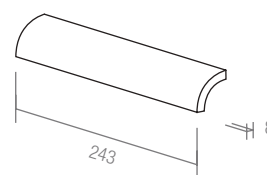

ART. 5730

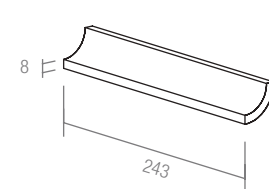

ART. 5607



ART. 5603

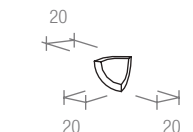

ART. 5604

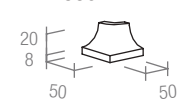

ART. 5608

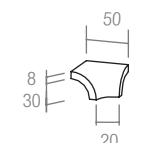

Produzione nei colori:  
Currently produced in the following colours:  
Production dans les couleurs :  
Lieferbar in den Farben:  
**Bianco Avorio, Bianco B**  
Superficie: Surface: Surface : Oberfläche: **matt**  
**Tundra 100**  
Superficie: Surface: Surface : Oberfläche: **satin, lucida**  
**Beach 101**  
Superficie: Surface: Surface : Oberfläche: **satin**



# tactile

GRANITOGRES



tactile, ontario segura cm 30x30 - 11<sup>3</sup>/<sub>4</sub>"x 11<sup>3</sup>/<sub>4</sub>"

## COLORI COLOURS COULEURS FARBEN

budapest

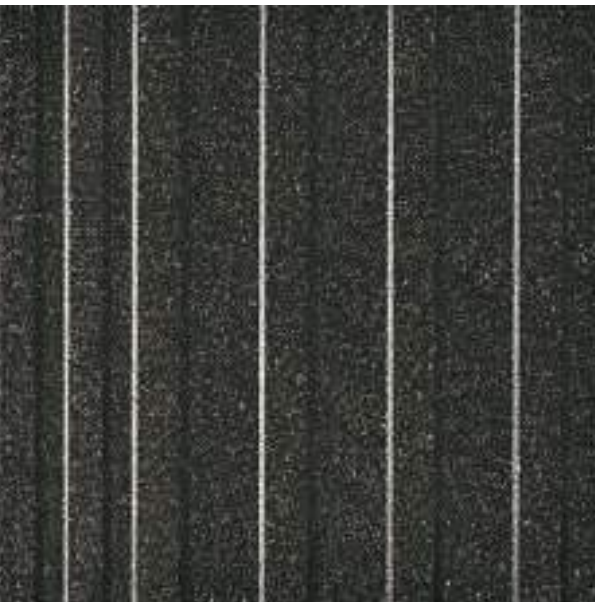

shanghai



bianco avorio



madrid

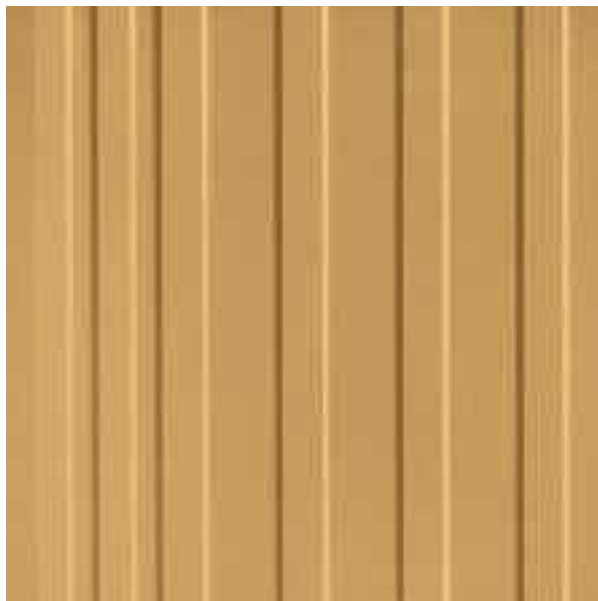

giallo ocra

Eventuali altri colori possono essere richiesti dal progettista per particolari esigenze architettoniche o progettuali.

Other colours may be requested by the designer for specific architectural or design needs.

D'autres couleurs peuvent être éventuellement demandées par le projeteur pour exigences architecturales ou projectuelles.

Evt. andere Farben können von Architekt, im Fall Von besondere Baubedürfnisse, nachgefragt werden.

PERCORSO GUIDA PER DISABILI VISIVI  
 GUIDED PATH FOR VISUALLY DISABLED PEOPLE  
 PARCOURS GUIDE POUR LES MALVOYANT ET AVEUGLES  
 SEHEBEHINDERTLEITWEG

**tactile**  
 GRANITOGRES

Codice di direzione rettilinea  
 Straight direction code  
 Code de direction rectiligne  
 Geradlinige Richtung

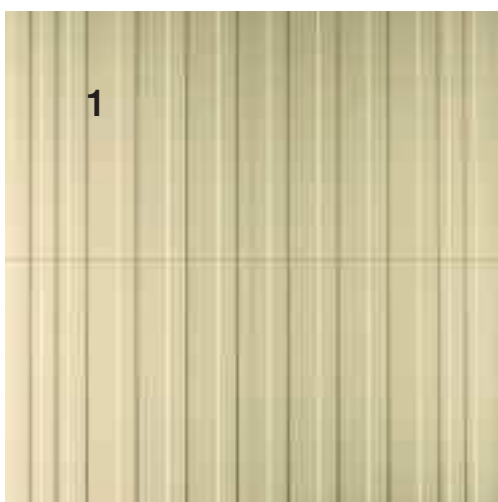

Codice di incrocio a T  
 T-junction code  
 Code de croisement en T  
 T-förmige Kreuzung



Codice di svolta obbligata ad L  
 Compulsory L-turn code  
 Code de tournant obligatoire en L  
 Obligatorisches L-förmiges Abbiegen

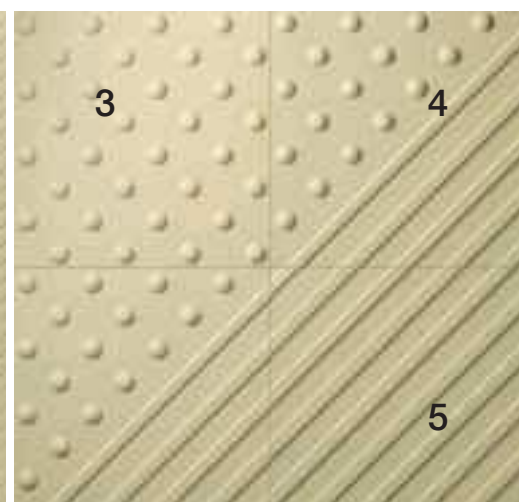

Codice di arresto-pericolo  
 Stop-danger code  
 Code d'arrêt-danger  
 Stehenbleiben-Gefahr

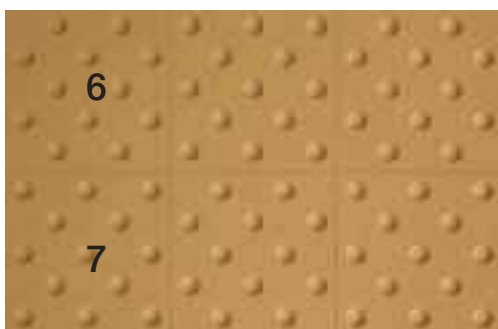

Codice di pericolo valicabile  
 Dangerous to pass code  
 Code de danger franchissable  
 Überwindbare Gefahr

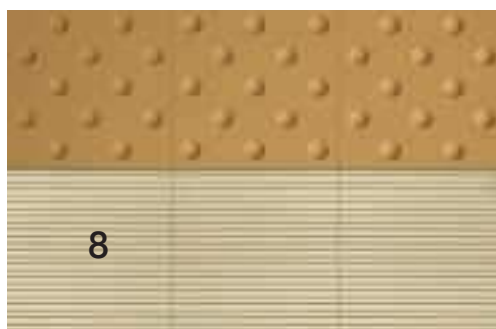

Codice di attenzione-servizio  
 Attention-service code  
 Code d'attention-service  
 Achtung-Service

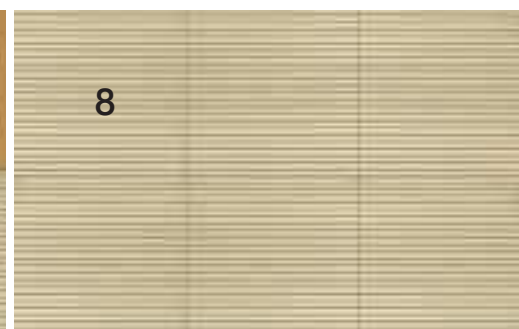

- 1. art. 30x30 rettilineo
- 2. art. 20x20 borchie
- 3. art. 30x30 tondi
- 4. art. 30x30 diagonale/tondi

- 5. art. 30x30 diagonale
- 6. art. 20x20 12 tondi
- 7. art. 20x20 13 tondi
- 8. art. 20x20 righe

e c o



**utility**

# eco**utility**

**caratteristiche tecniche**

technical features

**caractéristiques techniques**

technische Eigenschaften

434 **granitogres**

438 **pietre native**

440 **granitoker**

444 **gresplus**

446 **ecogres**

448 **stonalizzazione**

shade variations

**variations d'ombre**

farbtonvarianten

449 **complementi  
in acciaio e alluminio**

accessories in steel  
and aluminium

**compléments en acier  
et en aluminium**

zusatzelemente aus  
Stahl und Aluminium

450 **voci di capitolato**

specifications

**cahier des charges**

ausschreibungstexte

452 **posa e manutenzione**













453 **installation and maintenance**

454 **pose et entretien**

455 **verlegung und Pflege**



## CARATTERISTICHE TECNICHE TECHNICAL FEATURES CARACTÉRISTIQUES TECHNIQUES TECHNISCHE EIGENSCHAFTEN

<b>GRANITOGRES</b>		<b>NORMA STANDARDS NORME NORM</b>	<b>RISULTATO PROVA* TEST RESULTS* RESULTATS DES ESSAIS* ERGEBNISSE*</b>
 classificazione prodotto product classification classement Klassifizierung		UNI EN 14411-G ISO 13006	gruppo B1a UGL completamente greificato group B1a UGL fully vitrified group B1a UGL grès cérame fin Gruppe B1a UGL Feinsteinzeug
 caratteristiche dimensionali e d'aspetto dimensional and surface quality caractéristiques de la surface Oberflächenqualität		UNI EN ISO 10545-2	tolleranze minime nella 1ª scelta very low tolerance des tolérances minimales en 1er choix Entspricht Normen
 assorbimento di acqua water absorption absorption d'eau Wasseraufnahme		UNI EN ISO 10545-3	< 0,1%
 resistenza alla flessione flexural strength résistance à la flexion Biegezug-Festigkeit		UNI EN ISO 10545-4	> 45 N/mm <sup>2</sup>
 resistenza al gelo frost resistance résistance au gel Frostwiderstandsfähigkeit		qualsiasi norma all standards toute norme Alle normen	garantita guaranteed garantie Frostsicher
 resistenza attacco chimico (esclusione acido fluoridrico) resistance to acids and alkalis (with the exception of hydrofluoric acid) résistance à l'attaque chimique (exclusion de l'acide fluorhydrique) Säure und Laugen Beständigkeit (mit Ausnahme von Fluorwasserstoff)		UNI EN ISO 10545-13	UA
 resistenza usura e abrasione wear and abrasion resistance résistance à l'usure et abrasion Abriebhärte		UNI EN ISO 10545-6	≤ 150 mm <sup>3</sup>
 dilatazione termica lineare linear thermal expansion coefficient linéaire de dilatation thermique Lineare Wärmeausdehnung		UNI EN ISO 10545-8	6 x 10 <sup>-6</sup>
 resistenza alle macchie stain resistance résistance aux taches Fleckenfestigkeit		UNI EN ISO 10545-14	garantita guaranteed garantie Frostsicher
 resistenza alla scivolosità (Superficie Naturale) slip resistance (Matt surface) résistance au glissement (Surface naturelle) Trittsicherheit (Natur Oberflächen)		DIN 51130 D.M. N° 236 del 14.06.89 Metodo B.C.R. BS7976-2:2002 BSEN13036-4:2011	vedere singole serie see every series voir les séries une par une Siehe einzelne Serie valore $\mu > 0,40^{**}$ PTV > 36 <sup>**</sup>
 resistenza dei colori alla luce colour resistance to sunlight exposure résistance de la couleur à la lumière Unveränderlichkeit der Farben wenn Strahlung zugesetzt wird		DIN 51094	nessuna variazione no change of colours couleurs inchangées Keinerlei Farbänderung

\* valore indicativo approx value donnée approximative Ungefähre Werte

\*\* Prova su superficie asciutta Test on a dry surface Essai sur surface sèche Test auf trockener Oberfläche

◆ Si rimanda all'elenco prodotti UPEC ufficiale, consultabile sul sito: Please see the official UPEC product list: Veuillez consulter la liste officielle produits UPEC: Sihe die offizielle UPEC-Produktliste auf der Website: <http://webapp.cstb.fr/upec-ceramique/>

Al pari dei materiali naturali di riferimento, l'aspetto estetico, la differenza di tono e le venature possono essere diverse da piastrella a piastrella.

Per una corretta comprensione della variabilità del prodotto è consigliabile prendere visione delle immagini a tutto ambiente sul catalogo di collezione, sul nostro sito all'indirizzo [www.casalgrandepadana.it](http://www.casalgrandepadana.it) o chiedere maggiori informazioni ai nostri concessionari.

Just like the natural materials they are inspired by, the aesthetics, colouration and veining of the tiles can differ. To properly gauge the suitability of a product, we advise that you view the full-space photos that you can find in our collection catalogue and on our website at [www.casalgrandepadana.com](http://www.casalgrandepadana.com). Alternatively, please ask a reseller for more information.

Tout comme pour les matières naturelles de référence, la différence de tonalité, les veines ainsi que l'aspect esthétique peuvent varier d'une dalle à l'autre.

Pour bien comprendre la variabilité du produit, il est conseillé de consulter les images d'ambiance présentes sur le catalogue de la collection, sur notre site à l'adresse [www.casalgrandepadana.fr](http://www.casalgrandepadana.fr) ou de demander plus d'informations à nos concessionnaires.

Wie bei den als Vorbild dienenden Naturmaterialien können sich auch hier das ästhetische Erscheinungsbild, der Farbtonunterschied und die Maserung von Fliese zu Fliese unterscheiden. Um die Variabilität des Produkts besser zu verstehen, raten wir Ihnen, die Bilder mit ausgestatteten Räumen im Kollektionskatalog auf unserer Website [www.casalgrandepadana.de](http://www.casalgrandepadana.de) zu konsultieren. Weitere Informationen können Sie auch bei unseren Vertragshändlern erhalten.



**NORMA ASTM  
ASTM STANDARDS**

**RISULTATO PROVA TEST RESULTS  
RESULTATS DES ESSAIS ERGEBNISSE**









ASTM C-373 impervious $\leq 0,5\%$	$< 0,1\%$ <sup>***</sup>
ASTM C-648 breaking strength $\geq 250$ lbf	425 lbf <sup>***</sup> 625 lbf <sup>****</sup>
ASTM C-1026 no sample must show alterations to surface	resistant
ASTM C-650 no sample must show alterations to surface	unaffected
ASTM C-1243 $< 175$ mm <sup>3</sup>	$\leq 150$ mm <sup>3</sup>
ASTM A137.1-2012 DCOF $\geq 0.42$	see every series

\*\*\* Test made on Granito 1, Arizona Matt

\*\*\*\* Test made on Marte Series

## PESI, MISURE E CONTENUTO DEI COLLI WEIGHT, SIZE AND CONTENTS OF THE PACKING POIDS, DIMENSIONS, CONTENU DES COLIS VERPACKUNGSGRÖSSEN/GEWICHTE

### GRANITOGRES

	 mm	 x	 x	 x 	 x	 x	 x	
cm 12,5x12,5	4 <sup>7</sup> / <sub>8</sub> "x4 <sup>7</sup> / <sub>8</sub> "	8	64	1,00	17,0	72	72,00	1.224
cm 12,5x25	4 <sup>7</sup> / <sub>8</sub> "x9 <sup>7</sup> / <sub>8</sub> "	8	32	0,92	17,0	78	71,60	1.217
cm 15x15	5 <sup>7</sup> / <sub>8</sub> "x5 <sup>7</sup> / <sub>8</sub> "	8	44	0,99	17,0	64	63,36	1.077
cm 15x15	5 <sup>7</sup> / <sub>8</sub> "x5 <sup>7</sup> / <sub>8</sub> "	9,4	40	0,90	21,6	64	57,60	1.244
cm 15x30	5 <sup>7</sup> / <sub>8</sub> "x11 <sup>3</sup> / <sub>4</sub> "	8	22	0,99	18,0	64	63,36	1.140
cm 15x60	5 <sup>7</sup> / <sub>8</sub> "x23 <sup>5</sup> / <sub>8</sub> "	9	12	1,08	21,0	40	43,20	907
cm 15x60	5 <sup>7</sup> / <sub>8</sub> "x23 <sup>5</sup> / <sub>8</sub> "	9,4	12	1,08	21,6	40	43,20	933
cm 15x90	5 <sup>7</sup> / <sub>8</sub> "x35 <sup>3</sup> / <sub>8</sub> "	10	6	0,81	24,0	48	38,88	933
cm 20x20	7 <sup>7</sup> / <sub>8</sub> "x7 <sup>7</sup> / <sub>8</sub> "	8	30	1,20	18,0	68	81,60	1.469
cm 25x25	9 <sup>7</sup> / <sub>8</sub> "x9 <sup>7</sup> / <sub>8</sub> "	8	16	1,00	17,0	78	78,00	1.326
cm 30x30	11 <sup>3</sup> / <sub>4</sub> "x11 <sup>3</sup> / <sub>4</sub> "	7,6	14	1,26	17,5	48	60,48	1.058
cm 30x30	11 <sup>3</sup> / <sub>4</sub> "x11 <sup>3</sup> / <sub>4</sub> " <i>levigata polished</i>	8	14	1,26	17,0	48	60,48	1.028
cm 30x30	11 <sup>3</sup> / <sub>4</sub> "x11 <sup>3</sup> / <sub>4</sub> "	8	13	1,17	18,0	48	56,16	1.011
cm 30x30	11 <sup>3</sup> / <sub>4</sub> "x11 <sup>3</sup> / <sub>4</sub> " <i>levigata polished</i>	9,4	13	1,17	20,0	48	56,16	1.123
cm 30x30	11 <sup>3</sup> / <sub>4</sub> "x11 <sup>3</sup> / <sub>4</sub> "	9,4	12	1,08	21,6	48	51,84	1.120
cm 30x30	11 <sup>3</sup> / <sub>4</sub> "x11 <sup>3</sup> / <sub>4</sub> "	11,2	10	0,90	26,0	48	43,20	1.123
cm 30x60	11 <sup>3</sup> / <sub>4</sub> "x23 <sup>5</sup> / <sub>8</sub> "	9	6	1,08	21,0	48	51,84	1.089
cm 30x60	11 <sup>3</sup> / <sub>4</sub> "x23 <sup>5</sup> / <sub>8</sub> " <i>levigata polished</i>	9,4	6	1,08	20,0	48	51,84	1.037
cm 30x60	11 <sup>3</sup> / <sub>4</sub> "x23 <sup>5</sup> / <sub>8</sub> "	9,4	6	1,08	21,6	48	51,84	1.120
cm 30x60	11 <sup>3</sup> / <sub>4</sub> "x23 <sup>5</sup> / <sub>8</sub> " <i>levigata polished</i>	10	5	0,90	23,0	48	43,20	994
cm 30x60	11 <sup>3</sup> / <sub>4</sub> "x23 <sup>5</sup> / <sub>8</sub> "	10	5	0,90	24,0	48	43,20	1.037
cm 40x40	15 <sup>3</sup> / <sub>4</sub> "x15 <sup>3</sup> / <sub>4</sub> "	9	8	1,28	21,0	48	61,44	1.290
cm 40x40	15 <sup>3</sup> / <sub>4</sub> "x15 <sup>3</sup> / <sub>4</sub> " <i>levigata polished</i>	9,4	8	1,28	19,0	48	61,44	1.167
cm 40x40	15 <sup>3</sup> / <sub>4</sub> "x15 <sup>3</sup> / <sub>4</sub> "	9,4	8	1,28	21,6	48	61,44	1.327
cm 45x45	17 <sup>3</sup> / <sub>4</sub> "x17 <sup>3</sup> / <sub>4</sub> "	9	5	1,01	21,0	34	34,41	723
cm 45x90	17 <sup>3</sup> / <sub>4</sub> "x35 <sup>3</sup> / <sub>8</sub> "	10	3	1,22	24,0	30	36,45	875
cm 60x60	23 <sup>5</sup> / <sub>8</sub> "x23 <sup>5</sup> / <sub>8</sub> "	10	4	1,44	24,0	30	43,20	1.037
cm 60x60	23 <sup>5</sup> / <sub>8</sub> "x23 <sup>5</sup> / <sub>8</sub> "	9,4	4	1,44	21,6	30	43,20	933
cm 60x60	23 <sup>5</sup> / <sub>8</sub> "x23 <sup>5</sup> / <sub>8</sub> "	14	3	1,08	32,0	30	32,40	1.037
cm 60x120	23 <sup>5</sup> / <sub>8</sub> "x47 <sup>1</sup> / <sub>4</sub> "	10	2	1,44	24,0	36	51,84	1.244
cm 60x120	23 <sup>5</sup> / <sub>8</sub> "x47 <sup>1</sup> / <sub>4</sub> "	9,4	2	1,44	21,6	36	51,84	1.120
cm 90x90	35 <sup>3</sup> / <sub>8</sub> "x35 <sup>3</sup> / <sub>8</sub> "	10	2	1,62	24,0	24	38,88	933

# GRANITOGRES



## BATTISCOPIA B.C. BULLNOSE

### PLINTHE À BORD ARRONDI STEH SOCKEL

cm 9x30	3½"x11¾"	Agorà - Ardesia - Granito 1 Granito evo - Granito 2 - Granito 3 Unicolore	30
cm 9x30	3½"x11¾"	Marte - Titano - Granito 2 Granito 3 - Unicolore	28
cm 9x40	3½"x15¾"		22
cm 9x45	3½"x17¾"		18
cm 9x60	3½"x23⅝"		18
cm 9x90	3½"x35⅜"		9
cm 10x20	4"x7⅞"		30

## GRADINO STEP TREAD

### NEZ DE MARCHE STUFENPLATTE

cm 30x30	11¾"x11¾"		13
cm 30x30	11¾"x11¾"	levigata polished	14
cm 30x30	11¾"x11¾"	Marte	12
cm 30x30	11¾"x11¾"	Marte levigata polished	13
cm 30x60	11¾"x23⅝"	Marte	6
cm 30x120	11¾"x47¼"		3

## GRADONE ASSEMBLATO

cm 30x33	11¾"x13"		4
cm 60x33	23⅝"x13"		4

## ANGOLARE ASSEMBLATO

cm 30x33	11¾"x13"		4
cm 60x33	23⅝"x13"		2

## GRADONE

cm 30x30	11¾"x11¾"		4
----------	-----------	--	---

## GRADONE ANGOLARE

cm 30x30	11¾"x11¾"		2
----------	-----------	--	---

## GRADONE TORO

cm 60x33	23⅝"x13"		4
cm 60x33	23⅝"x13"	Con bordo antiscivolo Step treadstep with non-slip edging Marche avec nez antidérapant Stufenplatte mit rutschsicherer Kante	1
cm 120x33	47¼"x13"		4

## ANGOLARE TORO

cm 60x33	23⅝"x13"		4
cm 120x33	47¼"x13"	Con bordo antiscivolo Step treadstep with non-slip edging Marche avec nez antidérapant Stufenplatte mit rutschsicherer Kante	2
cm 60x33	23⅝"x13"		4

## ZOCCOLO SKIRTING PLINTHE HOHLKEHLSOCKEL

cm 10x20	4"x7⅞"		30
cm 10x30	4"x11¾"		30
cm 15x30	5⅞"x11¾"		12

## SGUSCETTA COVE GORGE RINNLEISTE

cm 4x20	1½"x7⅞"		30
---------	---------	--	----

## TOZZETTO INSERT CABOCHON EINLEGER

cm 9x9	3½"x3½"		35
cm 9x9	3½"x3½"	Marte - Pietre Rare - Titano	33

## LISTELLO LISTEL LISTEL ZEIERLEISTE

cm 9x30	3½"x11¾"		30
cm 9x30	3½"x11¾"	Marte	28
cm 9x40	3½"x16"		22
cm 9x60	3½"x23⅝"		18

## TERMINALE STEP TREAD REBORD BECHKENRANDPLATTE











cm 15x30x3,5	5⅞"x11¾"x1⅜"		6
--------------	--------------	--	---



## CARATTERISTICHE TECNICHE TECHNICAL FEATURES CARACTÉRISTIQUES TECHNIQUES TECHNISCHE EIGENSCHAFTEN

### PIETRE NATIVE



	NORMA STANDARDS NORME NORM	RISULTATO PROVA* TEST RESULTS* RESULTATS DES ESSAIS* ERGEBNISSE*
 classificazione prodotto product classification classement Klassifizierung	UNI EN 14411-G ISO 13006	gruppo B1a completamente greificato group B1a fully vitrified group B1a grès cérame fin Gruppe B1a Feinsteinzeug
 caratteristiche dimensionali e d'aspetto dimensional and surface quality caractéristiques de la surface Oberflächenqualität	UNI EN ISO 10545-2	tolleranze minime nella 1ª scelta very low tolerance des tolérances minimales en 1er choix Entspricht Normen
 assorbimento di acqua water absorption absorption d'eau Wasseraufnahme	UNI EN ISO 10545-3	< 0,1%
 resistenza alla flessione flexural strength résistance à la flexion Biegezug-Festigkeit	UNI EN ISO 10545-4	> 45 N/mm <sup>2</sup>
 resistenza al gelo frost resistance résistance au gel Frostwiderstandsfähigkeit	qualsiasi norma all standards toute norme Alle normen	garantita guaranteed garantie Frostsicher
 resistenza attacco chimico (esclusione acido fluoridrico) resistance to acids and alkalis (with the exception of hydrofluoric acid) résistance à l'attaque chimique (exclusion de l'acide fluorhydrique) Säure und Laugen Beständigkeit (mit Ausnahme von Fluorwasserstoff)	UNI EN ISO 10545-13	UA
 resistenza usura e abrasione wear and abrasion resistance résistance à l'usure et abrasion Abriebhärte	UNI EN ISO 10545-6	≤ 150 mm <sup>3</sup>
 dilatazione termica lineare linear thermal expansion coefficient linéaire de dilatation thermique Lineare Wärmeausdehnung	UNI EN ISO 10545-8	6 x 10 <sup>-6</sup>
 resistenza alle macchie stain resistance résistance aux taches Fleckenfestigkeit	UNI EN ISO 10545-14	garantita guaranteed garantie Frostsicher
 resistenza alla scivolosità (Superficie Naturale) slip resistance (Matt surface) résistance au glissement (Surface naturelle) Trittsicherheit (Natur Oberflächen)	DIN 51130 D.M. N° 236 del 14.06.89 Metodo B.C.R. BS7976-2:2002 BSEN13036-4:2011	vedere singole serie see every series voir les séries une par une Siehe einzelne Serie valore $\mu > 0,40^{**}$ PTV > 36 <sup>**</sup>
 resistenza dei colori alla luce colour resistance to sunlight exposure résistance de la couleur à la lumière Unveränderlichkeit der Farben wenn Strahlung zugesetzt wird	DIN 51094	nessuna variazione no change of colours couleurs inchangées Keinerlei Farbänderung

\* valore indicativo approx value donnée approximative Ungefährere Werte

\*\* Prova su superficie asciutta Test on a dry surface Essai sur surface sèche Test auf trockener Oberfläche

◆ Si rimanda all'elenco prodotti UPEC ufficiale, consultabile sul sito: Please see the official UPEC product list: Veuillez consulter la liste officielle produits UPEC: Sihe die offizielle UPEC-Produktliste auf der Website: <http://webapp.cstb.fr/upec-ceramique/>

Al pari dei materiali naturali di riferimento, l'aspetto estetico, la differenza di tono e le venature possono essere diverse da piastrella a piastrella.

Per una corretta comprensione della variabilità del prodotto è consigliabile prendere visione delle immagini a tutto ambiente sul catalogo di collezione, sul nostro sito all'indirizzo [www.casalgrandepadana.it](http://www.casalgrandepadana.it) o chiedere maggiori informazioni ai nostri concessionari.

Just like the natural materials they are inspired by, the aesthetics, colouration and veining of the tiles can differ. To properly gauge the suitability of a product, we advise that you view the full-space photos that you can find in our collection catalogue and on our website at [www.casalgrandepadana.com](http://www.casalgrandepadana.com). Alternatively, please ask a reseller for more information.

Tout comme pour les matières naturelles de référence, la différence de tonalité, les veines ainsi que l'aspect esthétique peuvent varier d'une dalle à l'autre.











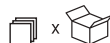
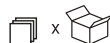
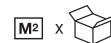
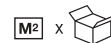
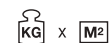
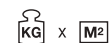

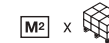
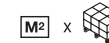





Pour bien comprendre la variabilité du produit, il est conseillé de consulter les images d'ambiance présentes sur le catalogue de la collection, sur notre site à l'adresse [www.casalgrandepadana.fr](http://www.casalgrandepadana.fr) ou de demander plus d'informations à nos concessionnaires.

Wie bei den als Vorbild dienenden Naturmaterialien können sich auch hier das ästhetische Erscheinungsbild, der Farbtonunterschied und die Maserung von Fliese zu Fliese unterscheiden. Um die Variabilität des Produkts besser zu verstehen, raten wir Ihnen, die Bilder mit ausgestatteten Räumen im Kollektionskatalog auf unserer Website [www.casalgrandepadana.de](http://www.casalgrandepadana.de) zu konsultieren. Weitere Informationen können Sie auch bei unseren Vertragshändlern erhalten.



## PESI, MISURE E CONTENUTO DEI COLLI WEIGHT, SIZE AND CONTENTS OF THE PACKING POIDS, DIMENSIONS, CONTENU DES COLIS VERPACKUNGSGRÖSSEN/GEWICHTE

### PIETRE NATIVE

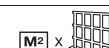
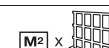
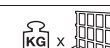
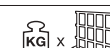
		 mm	 x 	 x 	 x 	 x 	 x 	 x 
cm 15x15	5 <sup>7</sup> / <sub>8</sub> "x5 <sup>7</sup> / <sub>8</sub> "	9	40	0,90	21,0	64	57,60	1.210
cm 15x60	5 <sup>7</sup> / <sub>8</sub> "x23 <sup>5</sup> / <sub>8</sub> "	9	12	1,08	21,0	40	43,20	907
cm 30x30	11 <sup>3</sup> / <sub>4</sub> "x11 <sup>3</sup> / <sub>4</sub> "	9	12	1,08	21,0	48	51,84	1.089
cm 30x60	11 <sup>3</sup> / <sub>4</sub> "x23 <sup>5</sup> / <sub>8</sub> "	9	6	1,08	21	48	51,84	1.089
cm 30x60	11 <sup>3</sup> / <sub>4</sub> "x23 <sup>5</sup> / <sub>8</sub> "	10	5	0,9	24	48	43,20	1.037
cm 37,5x75,5	14 <sup>1</sup> / <sub>2</sub> "x3"	9	4	1,13	21	54	61,02	1.281
cm 37,5x75,5	14 <sup>1</sup> / <sub>2</sub> "x3"	10	4	1,13	24	48	54,42	1.302
cm 45x45	17 <sup>3</sup> / <sub>4</sub> "x17 <sup>3</sup> / <sub>4</sub> "	9	5	1,01	21	34	34,41	723
cm 45x45	17 <sup>3</sup> / <sub>4</sub> "x17 <sup>3</sup> / <sub>4</sub> "	10	5	1,01	24	34	34,41	826
cm 45x90	17 <sup>3</sup> / <sub>4</sub> "x35 <sup>3</sup> / <sub>8</sub> "	20	2	0,81	46	26	21,06	969
cm 45x90	17 <sup>3</sup> / <sub>4</sub> "x35 <sup>3</sup> / <sub>8</sub> "	10	3	1,22	24	30	36,45	875
cm 60x60	23 <sup>5</sup> / <sub>8</sub> "x23 <sup>5</sup> / <sub>8</sub> "	4,9	8	2,88	11,3	30	86,40	976
cm 60x60	23 <sup>5</sup> / <sub>8</sub> "x23 <sup>5</sup> / <sub>8</sub> "	10	4	1,44	24	30	43,20	1.037
cm 60x60	23 <sup>5</sup> / <sub>8</sub> "x23 <sup>5</sup> / <sub>8</sub> "	14	3	1,08	32	30	32,40	1.037
cm 60x60	23 <sup>5</sup> / <sub>8</sub> "x23 <sup>5</sup> / <sub>8</sub> "	20	2	0,72	46	32	23,04	1.060
cm 60x120	23 <sup>5</sup> / <sub>8</sub> "x47 <sup>1</sup> / <sub>4</sub> "	4,9	4	2,88	11,3	24	69,12	781
cm 60x120	23 <sup>5</sup> / <sub>8</sub> "x47 <sup>1</sup> / <sub>4</sub> "	10	2	1,44	24	36	51,84	1.244
cm 60x120	23 <sup>5</sup> / <sub>8</sub> "x47 <sup>1</sup> / <sub>4</sub> "	20	1	0,72	46	36	25,92	1.192
cm 75,5x75,5	29 <sup>3</sup> / <sub>4</sub> "x29 <sup>3</sup> / <sub>4</sub> "	10	2	1,14	24	42	47,88	1.149
cm 75,5x151	29 <sup>3</sup> / <sub>4</sub> "x59 <sup>1</sup> / <sub>2</sub> "	10	2	2,28	24	22	50,16	1.204
cm 90x90	35 <sup>3</sup> / <sub>8</sub> "x35 <sup>3</sup> / <sub>8</sub> "	10	2	1,62	24	24	38,88	933
cm 90x90	35 <sup>3</sup> / <sub>8</sub> "x35 <sup>3</sup> / <sub>8</sub> "	20	2	0,81	46	24	19,44	894
cm 90x180	35 <sup>3</sup> / <sub>8</sub> "x70 <sup>7</sup> / <sub>8</sub> "	10	1	1,62	24	30	48,60	1.166
cm 120x120	47 <sup>1</sup> / <sub>4</sub> "x47 <sup>1</sup> / <sub>4</sub> "	6,5	2	2,88	15	24	69,12	1.037
cm 120x120	47 <sup>1</sup> / <sub>4</sub> "x47 <sup>1</sup> / <sub>4</sub> "	10	1	1,44	24	30	43,20	1.037
				 x 	 x 	 x 	 x 	 x 
cm 120x240	47 <sup>1</sup> / <sub>4</sub> "x94 <sup>1</sup> / <sub>2</sub> "	6,5	1	2,88	15	20	57,6	864
cm 120x260	47 <sup>1</sup> / <sub>4</sub> "x102 <sup>3</sup> / <sub>8</sub> "	6,5	1	3,12	15	20	62,4	936
cm 120x278	47 <sup>1</sup> / <sub>4</sub> "x109 <sup>1</sup> / <sub>2</sub> "	6,5	1	3,34	15	20	66,72	1.001
cm 160x320	63"x126"	12	1	5,12	27	9	46,08	1.244
						 x 	 x 	 x 
cm 160x320	63"x126"	12	1	5,12	27	20	102,4	2.765

#### BATTISCOPA B.C. BULLNOSE

#### PLINTHE À BORD ARRONDI STEHSOCKEL

cm 9x30	3 <sup>1</sup> / <sub>2</sub> "x11 <sup>3</sup> / <sub>4</sub> "	28
cm 9x45	3 <sup>1</sup> / <sub>2</sub> "x18"	18
cm 7x60	2 <sup>3</sup> / <sub>4</sub> "x23 <sup>5</sup> / <sub>8</sub> "	18
cm 9x60	3 <sup>1</sup> / <sub>2</sub> "x23 <sup>5</sup> / <sub>8</sub> "	18
cm 7x75,5	2 <sup>3</sup> / <sub>4</sub> "x29 <sup>3</sup> / <sub>4</sub> "	8
cm 7x90	2 <sup>3</sup> / <sub>4</sub> "x35 <sup>3</sup> / <sub>8</sub> "	9
cm 9x90	3 <sup>1</sup> / <sub>2</sub> "x35 <sup>3</sup> / <sub>8</sub> "	9

#### GRADINO STEP TREAD NEZ DE MARCHE STUFENPLATTE

cm 30x30	11 <sup>3</sup> / <sub>4</sub> "x11 <sup>3</sup> / <sub>4</sub> "	12
cm 30x60	11 <sup>3</sup> / <sub>4</sub> "x23 <sup>5</sup> / <sub>8</sub> "	6
cm 45x45	17 <sup>3</sup> / <sub>4</sub> "x17 <sup>3</sup> / <sub>4</sub> "	5
cm 30x120	11 <sup>3</sup> / <sub>4</sub> "x47 <sup>1</sup> / <sub>4</sub> "	3

#### GRADONE ASSEMBLATO

cm 30x33	11 <sup>3</sup> / <sub>4</sub> "x13"	4
cm 60x33	23 <sup>5</sup> / <sub>8</sub> "x13"	4
cm 120x33	47 <sup>1</sup> / <sub>4</sub> "x13"	2

#### ANGOLARE ASSEMBLATO

cm 30x33	11 <sup>3</sup> / <sub>4</sub> "x13"	2
cm 60x33	23 <sup>5</sup> / <sub>8</sub> "x13"	3
cm 120x33	47 <sup>1</sup> / <sub>4</sub> "x13"	1

#### TERMINALE STEP TREAD REBORD BECHKENRANDPLATTE

cm 15x30x3,5	5 <sup>7</sup> / <sub>8</sub> "x11 <sup>3</sup> / <sub>4</sub> "x1 <sup>3</sup> / <sub>8</sub> "	8
--------------	--	---



## CARATTERISTICHE TECNICHE TECHNICAL FEATURES CARACTÉRISTIQUES TECHNIQUES TECHNISCHE EIGENSCHAFTEN











### GRANITOKER



PT0078

#### NORMA STANDARDS NORME NORM

#### RISULTATO PROVA\* TEST RESULTS\* RESULTATS DES ESSAIS\* ERGEBNISSE\*

	classificazione prodotto product classification classement Klassifizierung	UNI EN 14411-G ISO 13006	gruppo B1a completamente greificato group B1a fully vitrified group B1a grès cérame fin Gruppe B1a Feinsteinzeug
	caratteristiche dimensionali e d'aspetto dimensional and surface quality caractéristiques de la surface Oberflächenqualität	UNI EN ISO 10545-2	tolleranze minime nella 1ª scelta very low tolerance des tolérances minimales en 1er choix Entspricht Normen
	assorbimento di acqua water absorption absorption d'eau Wasseraufnahme	UNI EN ISO 10545-3	< 0,1%
	resistenza alla flessione flexural strength résistance à la flexion Biegezug-Festigkeit	UNI EN ISO 10545-4	> 45 N/mm <sup>2</sup>
	resistenza al gelo frost resistance résistance au gel Frostwiderstandsfähigkeit	qualsiasi norma all standards toute norme Alle normen	garantita guaranteed garantie Frostsicher
	resistenza attacco chimico (esclusione acido fluoridrico) resistance to acids and alkalis (with the exception of hydrofluoric acid) résistance à l'attaque chimique (exclusion de l'acide fluorhydrique) Säure und Laugen Beständigkeit (mit Ausnahme von Fluorwasserstoff)	UNI EN ISO 10545-13	GA
	resistenza usura e abrasione wear and abrasion resistance résistance à l'usure et abrasion Abriebhärte	UNI EN ISO 10545-6	≤ 150 mm <sup>3</sup>
	dilatazione termica lineare linear thermal expansion coefficient linéaire de dilatation thermique Lineare Wärmeausdehnung	UNI EN ISO 10545-8	6 x 10 <sup>-6</sup>
	resistenza alle macchie stain resistance résistance aux taches Fleckenfestigkeit	UNI EN ISO 10545-14	garantita guaranteed garantie Frostsicher
	resistenza alla scivolosità (Superficie Naturale) slip resistance (Matt surface) résistance au glissement (Surface naturelle) Trittsicherheit (Natur Oberflächen)	DIN 51130 D.M. N° 236 del 14.06.89 Metodo B.C.R. BS7976-2:2002 BSEN13036-4:2011	vedere singole serie see every series voir les séries une par une Siehe einzelne Serie valore $\mu > 0,40^{**}$ PTV > 36 <sup>**</sup>
	resistenza dei colori alla luce colour resistance to sunlight exposure résistance de la couleur à la lumière Unveränderlichkeit der Farben wenn Strahlung zugesetzt wird	DIN 51094	nessuna variazione no change of colours couleurs inchangées Keinerlei Farbänderung

\* valore indicativo approx value donnée approximative Ungefähre Werte

\*\* Prova su superficie asciutta Test on a dry surface Essai sur surface sèche Test auf trockener Oberfläche

◆ Si rimanda all'elenco prodotti UPEC ufficiale, consultabile sul sito: Please see the official UPEC product list: Veuillez consulter la liste officielle produits UPEC: Siehe die offizielle UPEC-Produktliste auf der Website: <http://webapp.cstb.fr/upec-ceramique/>

Al pari dei materiali naturali di riferimento, l'aspetto estetico, la differenza di tono e le venature possono essere diverse da piastrella a piastrella.

Per una corretta comprensione della variabilità del prodotto è consigliabile prendere visione delle immagini a tutto ambiente sul catalogo di collezione, sul nostro sito all'indirizzo [www.casalgrandepadana.it](http://www.casalgrandepadana.it) o chiedere maggiori informazioni ai nostri concessionari.

Just like the natural materials they are inspired by, the aesthetics, colouration and veining of the tiles can differ. To properly gauge the suitability of a product, we advise that you view the full-space photos that you can find in our collection catalogue and on our website at [www.casalgrandepadana.com](http://www.casalgrandepadana.com). Alternatively, please ask a reseller for more information.











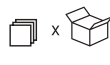

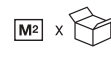
Tout comme pour les matières naturelles de référence, la différence de tonalité, les veines ainsi que l'aspect esthétique peuvent varier d'une dalle à l'autre.

Pour bien comprendre la variabilité du produit, il est conseillé de consulter les images d'ambiance présentes sur le catalogue de la collection, sur notre site à l'adresse [www.casalgrandepadana.fr](http://www.casalgrandepadana.fr) ou de demander plus d'informations à nos concessionnaires.

Wie bei den als Vorbild dienenden Naturmaterialien können sich auch hier das ästhetische Erscheinungsbild, der Farbtonunterschied und die Maserung von Fliese zu Fliese unterscheiden. Um die Variabilität des Produkts besser zu verstehen, raten wir Ihnen, die Bilder mit ausgestatteten Räumen im Kollektionskatalog auf unserer Website [www.casalgrandepadana.de](http://www.casalgrandepadana.de) zu konsultieren. Weitere Informationen können Sie auch bei unseren Vertragshändlern erhalten.











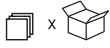

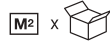
## PESI, MISURE E CONTENUTO DEI COLLI WEIGHT, SIZE AND CONTENTS OF THE PACKING POIDS, DIMENSIONS, CONTENU DES COLIS VERPACKUNGSGRÖSSEN/GEWICHTE



















### GRANITOKER

		 mm	 x 	 x 	 x 	 x 	 x 	 x 
cm 10x60	4"x23 <sup>5</sup> / <sub>8</sub> "	9	18	1,08	21,0	48	51,84	1.089
cm 11x90	4 <sup>3</sup> / <sub>8</sub> "x35 <sup>3</sup> / <sub>8</sub> "	10	9	0,89	24,0	50	44,55	1.069
cm 15x91	5 <sup>7</sup> / <sub>8</sub> "x35 <sup>3</sup> / <sub>4</sub> " <i>non rettificato unrectified</i>	8,5	7	0,96	19,5	48	45,84	894
cm 15x90	5 <sup>7</sup> / <sub>8</sub> "x35 <sup>3</sup> / <sub>8</sub> "	9	6	0,81	21,0	48	38,88	933
cm 15x90	5 <sup>7</sup> / <sub>8</sub> "x35 <sup>3</sup> / <sub>8</sub> "	10	6	0,81	24,0	48	38,88	933
cm 15x120	5 <sup>7</sup> / <sub>8</sub> "x47 <sup>1</sup> / <sub>4</sub> "	10	5	0,90	24,0	48	43,20	1.037
cm 15x120	5 <sup>7</sup> / <sub>8</sub> "x47 <sup>1</sup> / <sub>4</sub> "	9	5	0,90	21,0	47	43,20	907
cm 20x20	7 <sup>7</sup> / <sub>8</sub> "x7 <sup>7</sup> / <sub>8</sub> "	9	28	1,12	21,0	68	76,16	1.599
cm 20x120	7 <sup>7</sup> / <sub>8</sub> "x47 <sup>1</sup> / <sub>4</sub> "	10	4	0,96	24,0	48	46,08	1.106
cm 20x120	7 <sup>7</sup> / <sub>8</sub> "x47 <sup>1</sup> / <sub>4</sub> "	9	4	0,96	21,0	42	40,32	847
cm 22,5x90	8 <sup>7</sup> / <sub>8</sub> "x35 <sup>3</sup> / <sub>8</sub> "	10	5	1,01	24,0	54	54,65	1.312
cm 22,5x180	8 <sup>7</sup> / <sub>8</sub> "x70 <sup>7</sup> / <sub>8</sub> "	10	3	1,22	24,0	40	48,80	1.171
cm 25x151	9 <sup>7</sup> / <sub>8</sub> "x59 <sup>1</sup> / <sub>2</sub> "	10	3	1,13	24,0	45	50,85	1.220
cm 30x60	11 <sup>3</sup> / <sub>4</sub> "x23 <sup>5</sup> / <sub>8</sub> " <i>non rettificato unrectified</i>	9	6	1,08	21,5	48	51,84	1.115
cm 30x60	11 <sup>3</sup> / <sub>4</sub> "x23 <sup>5</sup> / <sub>8</sub> "	10	6	1,08	24,0	48	43,20	1.037
cm 30x60	11 <sup>3</sup> / <sub>4</sub> "x23 <sup>5</sup> / <sub>8</sub> "	9	6	1,08	21,0	48	51,84	1.089
cm 30x120	11 <sup>3</sup> / <sub>4</sub> "x47 <sup>1</sup> / <sub>4</sub> "	10	3	1,08	24,0	45	48,60	1.166
cm 30x120	11 <sup>3</sup> / <sub>4</sub> "x47 <sup>1</sup> / <sub>4</sub> "	9	3	1,08	21,0	36	38,88	816
cm 30x180	11 <sup>3</sup> / <sub>4</sub> "x70 <sup>7</sup> / <sub>8</sub> "	10	2	1,08	24,0	45	48,60	1.166
cm 37,5x75,5	14 <sup>1</sup> / <sub>2</sub> "x29 <sup>3</sup> / <sub>4</sub> "	9	4	1,13	21,0	54	61,02	1.281
cm 37,5x75,5	14 <sup>1</sup> / <sub>2</sub> "x29 <sup>3</sup> / <sub>4</sub> "	10	4	1,13	24,0	48	54,24	1.302
cm 40x120	15 <sup>3</sup> / <sub>4</sub> "x47 <sup>1</sup> / <sub>4</sub> "	20	2	0,96	46,0	32	30,72	1.413
cm 45x90	17 <sup>3</sup> / <sub>4</sub> "x35 <sup>3</sup> / <sub>8</sub> "	9	3	1,22	21,0	30	36,60	769
cm 45x90	17 <sup>3</sup> / <sub>4</sub> "x35 <sup>3</sup> / <sub>8</sub> "	10	3	1,22	24,0	30	36,60	878
cm 60x60	23 <sup>5</sup> / <sub>8</sub> "x23 <sup>5</sup> / <sub>8</sub> "	9	4	1,44	21,0	30	43,20	907
cm 60x60	23 <sup>5</sup> / <sub>8</sub> "x23 <sup>5</sup> / <sub>8</sub> "	10	4	1,44	24,0	30	43,20	1.037
cm 60x60	23 <sup>5</sup> / <sub>8</sub> "x23 <sup>5</sup> / <sub>8</sub> "	20	2	0,72	46,0	32	23,04	1.060
cm 60x120	23 <sup>5</sup> / <sub>8</sub> "x47 <sup>1</sup> / <sub>4</sub> "	9	2	1,44	21,0	36	51,84	1.089
cm 60x120	23 <sup>5</sup> / <sub>8</sub> "x47 <sup>1</sup> / <sub>4</sub> "	10	2	1,44	24,0	36	51,84	1.244
cm 75,5x75,5	29 <sup>3</sup> / <sub>4</sub> "x29 <sup>3</sup> / <sub>4</sub> "	10	2	1,14	24,0	42	47,88	1.149
cm 75,5x151	29 <sup>3</sup> / <sub>4</sub> "x29 <sup>1</sup> / <sub>2</sub> "	10	2	2,28	24,0	22	50,16	1.204
cm 90x90	35 <sup>3</sup> / <sub>8</sub> "x35 <sup>3</sup> / <sub>8</sub> "	10	2	1,62	24,0	24	38,88	933
cm 90x90	35 <sup>3</sup> / <sub>8</sub> "x35 <sup>3</sup> / <sub>8</sub> "	20	1	0,81	48,0	24	19,44	894
cm 90x180	35 <sup>3</sup> / <sub>8</sub> "x70 <sup>7</sup> / <sub>8</sub> "	10	1	1,62	24,0	30	48,60	1.166

## PESI, MISURE E CONTENUTO DEI COLLI WEIGHT, SIZE AND CONTENTS OF THE PACKING POIDS, DIMENSIONS, CONTENU DES COLIS VERPACKUNGSGRÖSSEN/GEWICHTE

### GRANITOKER

		 mm	 x 	 x 	 x 	 x 	 x 	 x 
cm 20x120	7 <sup>7</sup> / <sub>8</sub> "x47 <sup>1</sup> / <sub>4</sub> "	6,5	6	1,44	15	45	64,80	972
cm 20x240	7 <sup>7</sup> / <sub>8</sub> "x94 <sup>1</sup> / <sub>4</sub> "	6,5	1	0,72	15	100	48,00	720
cm 30x90	11 <sup>3</sup> / <sub>4</sub> "x35 <sup>3</sup> / <sub>8</sub> "	6	6	1,62	14	30	48,60	680
cm 30x120	11 <sup>3</sup> / <sub>4</sub> "x47 <sup>1</sup> / <sub>4</sub> "	6,5	5	1,80	15	36	64,80	972
cm 30x240	11 <sup>3</sup> / <sub>4</sub> "x94 <sup>1</sup> / <sub>2</sub> "	6,5	1	0,72	15	80	57,60	864
cm 45x90	17 <sup>3</sup> / <sub>4</sub> "x35 <sup>3</sup> / <sub>8</sub> "	6	5	2,03	14	30	60,75	851
cm 60x120	23 <sup>5</sup> / <sub>8</sub> "x47 <sup>1</sup> / <sub>4</sub> "	6,5	3	2,16	15	24	51,84	778
cm 90x90	35 <sup>3</sup> / <sub>8</sub> "x35 <sup>3</sup> / <sub>8</sub> "	6	3	2,43	14	26	63,18	885
120x120 cm	47 <sup>1</sup> / <sub>4</sub> "x47 <sup>1</sup> / <sub>4</sub> "	6,5	2	2,88	15	24	69,12	1.037
120x120 cm	47 <sup>1</sup> / <sub>4</sub> "x47 <sup>1</sup> / <sub>4</sub> "	10	1	1,44	24	30	43,20	1.037

		 mm		 x 	 x 	 x 	 x 	 x 
cm 90x270	35 <sup>3</sup> / <sub>8</sub> "x106 <sup>1</sup> / <sub>4</sub> "	6	1	2,43	14	22	53,46	748
cm 120x240	47 <sup>1</sup> / <sub>4</sub> "x94 <sup>1</sup> / <sub>2</sub> "	6,5	1	2,88	15	20	57,60	864
cm 120x260	47 <sup>1</sup> / <sub>4</sub> "x102 <sup>3</sup> / <sub>8</sub> "	6,5	1	3,12	15	20	62,40	936
cm 120x278	47 <sup>1</sup> / <sub>4</sub> "x109 <sup>1</sup> / <sub>2</sub> "	6,5	1	3,34	15	20	66,72	1.001
cm 160x320	63"x126"	6,5	1	5,12	15	16	81,92	1.229
cm 160x320	63"x126"	12	1	5,12	27	9	46,08	1.244
						 x 	 x 	 x 
cm 160x320	63"x126"	12	1	5,12	27	20	102,40	2.765

# GRANITOKER



## BATTISCOPIA B.C. BULLNOSE

### PLINTHE À BORD ARRONDI STEH SOCKEL

cm 7x60	2 <sup>3</sup> / <sub>4</sub> "x23 <sup>5</sup> / <sub>8</sub> "	18
cm 7x75,5	2 <sup>3</sup> / <sub>4</sub> "x29 <sup>3</sup> / <sub>4</sub> "	8
cm 7x90	2 <sup>3</sup> / <sub>4</sub> "x35 <sup>3</sup> / <sub>8</sub> "	9
cm 7x120	2 <sup>3</sup> / <sub>4</sub> "x47 <sup>1</sup> / <sub>4</sub> "	8
cm 9x60	3 <sup>1</sup> / <sub>4</sub> "x23 <sup>5</sup> / <sub>8</sub> "	18
cm 9x90	3 <sup>1</sup> / <sub>4</sub> "x35 <sup>3</sup> / <sub>8</sub> "	9
cm 9x180	3 <sup>1</sup> / <sub>2</sub> "x70 <sup>7</sup> / <sub>8</sub> "	4

## GRADINO STEP TREAD

### NEZ DE MARCHE STUFENPLATTE

cm 30x60	11 <sup>3</sup> / <sub>4</sub> "x23 <sup>5</sup> / <sub>8</sub> "	6
cm 30x90	11 <sup>3</sup> / <sub>4</sub> "x35 <sup>3</sup> / <sub>8</sub> "	4
cm 30x120	11 <sup>3</sup> / <sub>4</sub> "x47 <sup>1</sup> / <sub>4</sub> "	3
cm 37,5x75,5	14 <sup>3</sup> / <sub>4</sub> "x29 <sup>3</sup> / <sub>4</sub> "	4

## ESAGONO

cm 30x51,9	11 <sup>3</sup> / <sub>4</sub> "x20 <sup>3</sup> / <sub>8</sub> "	4
------------	---	---

## CHEVRON A

cm 31x29,5	12 <sup>1</sup> / <sub>4</sub> "x11 <sup>5</sup> / <sub>8</sub> "	6
------------	---	---

## CHEVRON B

cm 14,6x50	5 <sup>3</sup> / <sub>4</sub> "x19 <sup>3</sup> / <sub>4</sub> "	12
------------	--	----

## GRADONE ASSEMBLATO

cm 60x33	23 <sup>5</sup> / <sub>8</sub> "x13"	4
cm 75,5x33	29 <sup>3</sup> / <sub>4</sub> "x13"	4
cm 90x33	35 <sup>3</sup> / <sub>8</sub> "x13"	2
cm 120x33	47 <sup>1</sup> / <sub>4</sub> "x13"	2
cm 180x33	70 <sup>7</sup> / <sub>8</sub> "x13"	1

## ANGOLARE ASSEMBLATO

cm 60x33	23 <sup>5</sup> / <sub>8</sub> "x13"	2
cm 75,5x33	29 <sup>3</sup> / <sub>4</sub> "x13"	3
cm 90x33	35 <sup>3</sup> / <sub>8</sub> "x13"	1
cm 120x33	47 <sup>1</sup> / <sub>4</sub> "x13"	1
cm 180x33	70 <sup>7</sup> / <sub>8</sub> "x13"	1

## TOZZETTO INSERT CABOCHON EINLEGER











cm 9,8x9,8	37 <sup>8</sup> / <sub>8</sub> "x37 <sup>8</sup> / <sub>8</sub> "	33
------------	---	----



## CARATTERISTICHE TECNICHE TECHNICAL FEATURES CARACTÉRISTIQUES TECHNIQUES TECHNISCHE EIGENSCHAFTEN

### GRESPLUS



	NORMA STANDARDS NORME NORM	RISULTATO PROVA* TEST RESULTS* RESULTATS DES ESSAIS* ERGEBNISSE*
 classificazione prodotto product classification classement Klassifizierung	UNI EN 14411-G ISO 13006	gruppo B1a completamente greificato group B1a fully vitrified group B1a grès cérame fin Gruppe B1a Feinsteinzeug
 caratteristiche dimensionali e d'aspetto dimensional and surface quality caractéristiques de la surface Oberflächenqualität	UNI EN ISO 10545-2	tolleranze minime nella 1 <sup>a</sup> scelta very low tolerance des tolérances minimales en 1er choix Entspricht Normen
 assorbimento di acqua water absorption absorption d'eau Wasseraufnahme	UNI EN ISO 10545-3	< 0,1%
 resistenza alla flessione flexural strength résistance à la flexion Biegezug-Festigkeit	UNI EN ISO 10545-4	> 45 N/mm <sup>2</sup>
 resistenza al gelo frost resistance résistance au gel Frostwiderstandsfähigkeit	qualsiasi norma all standards toute norme Alle normen	garantita guaranteed garantie Frostsicher
 resistenza attacco chimico (esclusione acido fluoridrico) resistance to acids and alkalis (with the exception of hydrofluoric acid) résistance à l'attaque chimique (exclusion de l'acide fluorhydrique) Säure und Laugen Beständigkeit (mit Ausnahme von Fluorwasserstoff)	UNI EN ISO 10545-13	GA
 resistenza usura e abrasione wear and abrasion resistance résistance à l'usure et abrasion Abriebhärte	UNI EN ISO 10545-7	≤ 150 mm <sup>3</sup>
 dilatazione termica lineare linear thermal expansion coefficient linéaire de dilatation thermique Lineare Wärmeausdehnung	UNI EN ISO 10545-8	6 x 10 <sup>-6</sup>
 resistenza alle macchie stain resistance résistance aux taches Fleckenfestigkeit	UNI EN ISO 10545-14	garantita guaranteed garantie Frostsicher
 resistenza alla scivolosità (Superficie Naturale) slip resistance (Matt surface) résistance au glissement (Surface naturelle) Trittsicherheit (Natur Oberflächen)	DIN 51130 D.M. N° 236 del 14.06.89 Metodo B.C.R. BS7976-2:2002 BSEN13036-4:2011	vedere singole serie see every series voir les séries une par une Siehe einzelne Serie valore $\mu > 0,40^{**}$ PTV > 36 <sup>**</sup>
 resistenza dei colori alla luce colour resistance to sunlight exposure résistance de la couleur à la lumière Unveränderlichkeit der Farben wenn Strahlung zugesetzt wird	DIN 51094	nessuna variazione no change of colours couleurs inchangées Keinerlei Farbänderung

\* valore indicativo approx value donnée approximative Ungefähre Werte

\*\* Prova su superficie asciutta Test on a dry surface Essai sur surface sèche Test auf trockener Oberfläche

◆ Si rimanda all'elenco prodotti UPEC ufficiale, consultabile sul sito: Please see the official UPEC product list: Veuillez consulter la liste officielle produits UPEC: Sihe die offizielle UPEC-Produktliste auf der Website: <http://webapp.cstb.fr/upec-ceramique/>

Al pari dei materiali naturali di riferimento, l'aspetto estetico, la differenza di tono e le venature possono essere diverse da piastrella a piastrella.

Per una corretta comprensione della variabilità del prodotto è consigliabile prendere visione delle immagini a tutto ambiente sul catalogo di collezione, sul nostro sito all'indirizzo [www.casalgrandepadana.it](http://www.casalgrandepadana.it) o chiedere maggiori informazioni ai nostri concessionari.

Just like the natural materials they are inspired by, the aesthetics, colouration and veining of the tiles can differ. To properly gauge the suitability of a product, we advise that you view the full-space photos that you can find in our collection catalogue and on our website at [www.casalgrandepadana.com](http://www.casalgrandepadana.com). Alternatively, please ask a reseller for more information.









Tout comme pour les matières naturelles de référence, la différence de tonalité, les veines ainsi que l'aspect esthétique peuvent varier d'une dalle à l'autre.

Pour bien comprendre la variabilité du produit, il est conseillé de consulter les images d'ambiance présentes sur le catalogue de la collection, sur notre site à l'adresse [www.casalgrandepadana.fr](http://www.casalgrandepadana.fr) ou de demander plus d'informations à nos concessionnaires.

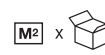
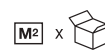
Wie bei den als Vorbild dienenden Naturmaterialien können sich auch hier das ästhetische Erscheinungsbild, der Farbtonunterschied und die Maserung von Fliese zu Fliese unterscheiden. Um die Variabilität des Produkts besser zu verstehen, raten wir Ihnen, die Bilder mit ausgestatteten Räumen im Kollektionskatalog auf unserer Website [www.casalgrandepadana.de](http://www.casalgrandepadana.de) zu konsultieren. Weitere Informationen können Sie auch bei unseren Vertragshändlern erhalten.

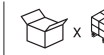
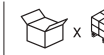
## PESI, MISURE E CONTENUTO DEI COLLI WEIGHT, SIZE AND CONTENTS OF THE PACKING POIDS, DIMENSIONS, CONTENU DES COLIS VERPACKUNGSGRÖSSEN/GEWICHTE

### GRESPLUS

	 mm	 x 	 x 	 x 	 x 	 x 	 x 	
cm 12,5x12,5	4 <sup>7</sup> / <sub>8</sub> "x4 <sup>7</sup> / <sub>8</sub> "	8	64	1,00	17,0	72	72,00	1.224
cm 12,5x25	4 <sup>7</sup> / <sub>8</sub> "x9 <sup>7</sup> / <sub>8</sub> "	8	32	0,92	17,0	78	71,60	1.217
cm 20x20	7 <sup>7</sup> / <sub>8</sub> "x7 <sup>7</sup> / <sub>8</sub> "	8	30	1,20	16,50	68	81,60	1.346
cm 25x25	9 <sup>7</sup> / <sub>8</sub> "x9 <sup>7</sup> / <sub>8</sub> "	8	16	1,00	17,0	78	78,00	1.326
cm 20x40	7 <sup>7</sup> / <sub>8</sub> "x15 <sup>3</sup> / <sub>4</sub> "	8	18	1,44	16,50	56	80,64	1.331
cm 30x60	11 <sup>3</sup> / <sub>4</sub> "x23 <sup>5</sup> / <sub>8</sub> "	8	7	1,26	18,0	48	60,48	1.089
cm 30x60	11 <sup>3</sup> / <sub>4</sub> "x23 <sup>5</sup> / <sub>8</sub> "	9	6	1,08	21,0	48	51,84	1.089
cm 37,5x75,5	14 <sup>1</sup> / <sub>2</sub> "x29 <sup>3</sup> / <sub>4</sub> "	10	4	1,13	24,0	48	54,24	1.302
cm 45x45	17 <sup>3</sup> / <sub>4</sub> "x17 <sup>3</sup> / <sub>4</sub> " <i>non rettificato unrectified</i>	8	6	1,22	18,5	34	41,31	764
cm 60x60	23 <sup>5</sup> / <sub>8</sub> "x23 <sup>5</sup> / <sub>8</sub> "	9	4	1,44	21,0	30	43,20	907
cm 60x60	23 <sup>5</sup> / <sub>8</sub> "x23 <sup>5</sup> / <sub>8</sub> "	20	2	0,72	46,0	32	23,04	1.060
cm 75,5x75,5	29 <sup>3</sup> / <sub>4</sub> "x29 <sup>3</sup> / <sub>4</sub> "	10	2	1,14	24,0	42	47,88	1.149
cm 60x120	23 <sup>5</sup> / <sub>8</sub> "x47 <sup>1</sup> / <sub>4</sub> "	9	2	1,44	21,0	36	51,84	1.089

#### BATTISCOPIA B.C. BULLNOSE PLINTE À BORD ARRONDI STEHSOCKEL

cm 7x60	2 <sup>3</sup> / <sub>4</sub> "x23 <sup>5</sup> / <sub>8</sub> "	18
cm 7x75,5	2 <sup>3</sup> / <sub>4</sub> "x29 <sup>3</sup> / <sub>4</sub> "	8
cm 8x40	3 <sup>1</sup> / <sub>8</sub> "x15 <sup>3</sup> / <sub>4</sub> "	22
cm 9x45	3 <sup>1</sup> / <sub>2</sub> "x17 <sup>3</sup> / <sub>4</sub> "	18
cm 9x60	3 <sup>1</sup> / <sub>2</sub> "x23 <sup>5</sup> / <sub>8</sub> "	18

#### GRADINO STEP TREAD NEZ DE MARCHE STUFENPLATTE

cm 30x60	11 <sup>3</sup> / <sub>4</sub> "x23 <sup>5</sup> / <sub>8</sub> "	6
cm 37,5x75,5	14 <sup>1</sup> / <sub>2</sub> "x29 <sup>3</sup> / <sub>4</sub> "	4

#### GRADONE ASSEMBLATO

cm 60x33	23 <sup>5</sup> / <sub>8</sub> "x13"	4
cm 75,5x33	29 <sup>3</sup> / <sub>4</sub> "x13"	2

#### ANGOLARE ASSEMBLATO

cm 60x33	23 <sup>5</sup> / <sub>8</sub> "x13"	2
cm 75,5x33	29 <sup>3</sup> / <sub>4</sub> "x13"	1

#### TERMINALE PEZZO UNICO PRESSATO

cm 15x30x3,5	5 <sup>7</sup> / <sub>8</sub> "x11 <sup>3</sup> / <sub>4</sub> "x1 <sup>3</sup> / <sub>8</sub> "	6
--------------	--	---

## CLASSIFICAZIONE DELLE PIASTRELLE DA PAVIMENTO IN BASE ALL'AMBIENTE DI DESTINAZIONE CLASSIFICATION OF THE FLOOR TILES ACCORDING TO THE FINAL DESTINATION CLASSIFICATION DES CARREAUX SELON L'ENTROIT DESTINE KLASSIFIZIERUNG DER BODENFLIESE NACH IHREM VERWENDUNGSZWECK

#### G1 Gruppo 1: Traffico leggero (bagni, camere da letto)

Group 1: Light wear (bathrooms, bedrooms)

Groupe 1: Trafic léger (salles de bains, chambres à coucher)

Gruppe 1: Leichte Beanspruchung (Bade und Schlafzimmer)

#### G2 Gruppo 2: Traffico-medio (appartamenti privati ad esclusione cucine)

Group 2: Medium wear (private apartments, kitchens excluded)

Groupe 2: Trafic moyen (appartements privés sauf cuisines)

Gruppe 2: Beanspruchung (Privatwohnungen außer Küchen)

#### G3 Gruppo 3: Traffico medio-forte (appartamenti, case private)

Group 3: Medium hard wear (flats and private houses)

Groupe 3: Trafic mi-fort (appartements et maisons)

Gruppe 3: Mittlere Beanspruchung (Wohnungen und Privathäuser)

#### G4 Gruppo 4: Traffico forte (ristoranti, uffici, edifici pubblici)

Group 4: Hard wear (restaurants, offices, public buildings)

Groupe 4: Trafic fort (restaurants, bureaux, édifices publics)









Gruppe 4: Starke Beanspruchung (Restaurant, Büros, öffentliche Gebäude)



## CARATTERISTICHE TECNICHE TECHNICAL FEATURES CARACTÉRISTIQUES TECHNIQUES TECHNISCHE EIGENSCHAFTEN

### ECOGRES



	NORMA STANDARDS NORME NORM	RISULTATO PROVA* TEST RESULTS* RESULTATS DES ESSAIS* ERGEBNISSE*
 classificazione prodotto product classification classement Klassifizierung	UNI EN 14411-H ISO 13006	gruppo B1b GL completamente greificato group B1b GL fully vitrified group B1b GL grès cérame fin Gruppe B1b GL Feinsteinzeug
 caratteristiche dimensionali e d'aspetto dimensional and surface quality caractéristiques de la surface Oberflächenqualität	UNI EN ISO 10545-2	tolleranze minime nella 1ª scelta very low tolerance des tolérances minimales en 1er choix Entspricht Normen
 resistenza alla flessione flexural strength résistance à la flexion Biegezug-Festigkeit	UNI EN ISO 10545-4	35 ÷ 40 N/mm <sup>2</sup>
 resistenza al gelo frost resistance résistance au gel Frostwiderstandsfähigkeit	qualsiasi norma all standards toute norme Alle normen	garantita guaranteed garantie Frostsicher
 resistenza attacco chimico (esclusione acido fluoridrico) resistance to acids and alkalis (with the exception of hydrofluoric acid) résistance à l'attaque chimique (exclusion de l'acide fluorhydrique) Säure und Laugen Beständigkeit (mit Ausnahme von Fluorwasserstoff)	UNI EN ISO 10545-13	GA
 resistenza usura e abrasione wear and abrasion resistance résistance à l'usure et abrasion Abriebhärte	UNI EN ISO 10545-7	vedere singole serie see every series voir les séries une par une Siehe einzelne Serie
 dilatazione termica lineare linear thermal expansion coefficient linéaire de dilatation thermique Lineare Wärmeausdehnung	UNI EN ISO 10545-8	6 x 10 <sup>-6</sup>
 resistenza alle macchie stain resistance résistance aux taches Fleckenfestigkeit	UNI EN ISO 10545-14	garantita guaranteed garantie Frostsicher
 resistenza alla scivolosità (Superficie Naturale) slip resistance (Matt surface) résistance au glissement (Surface naturelle) Trittsicherheit (Natur Oberflächen)	DIN 51130 D.M. N° 236 del 14.06.89 Metodo B.C.R. BS7976-2:2002 BSEN13036-4:2011	vedere singole serie see every series voir les séries une par une Siehe einzelne Serie valore $\mu > 0,40^{**}$ PTV > 36 <sup>**</sup>

\* valore indicativo approx value donnée approximative Ungefähre Werte

\*\* Prova su superficie asciutta Test on a dry surface Essai sur surface sèche Test auf trockener Oberfläche

◆ Si rimanda all'elenco prodotti UPEC ufficiale, consultabile sul sito: Please see the official UPEC product list: Veuillez consulter la liste officielle produits UPEC: Sihe die offizielle UPEC-Produktliste auf der Website: <http://webapp.cstb.fr/upec-ceramique/>

Al pari dei materiali naturali di riferimento, l'aspetto estetico, la differenza di tono e le venature possono essere diverse da piastrella a piastrella.

Per una corretta comprensione della variabilità del prodotto è consigliabile prendere visione delle immagini a tutto ambiente sul catalogo di collezione, sul nostro sito all'indirizzo [www.casalgrandepadana.it](http://www.casalgrandepadana.it) o chiedere maggiori informazioni ai nostri concessionari.

Just like the natural materials they are inspired by, the aesthetics, colouration and veining of the tiles can differ. To properly gauge the suitability of a product, we advise that you view the full-space photos that you can find in our collection catalogue and on our website at [www.casalgrandepadana.com](http://www.casalgrandepadana.com). Alternatively, please ask a reseller for more information.

Tout comme pour les matières naturelles de référence, la différence de tonalité, les veines ainsi que l'aspect esthétique peuvent varier d'une dalle à l'autre.











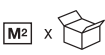

Pour bien comprendre la variabilité du produit, il est conseillé de consulter les images d'ambiance présentes sur le catalogue de la collection, sur notre site à l'adresse [www.casalgrandepadana.fr](http://www.casalgrandepadana.fr) ou de demander plus d'informations à nos concessionnaires.

Wie bei den als Vorbild dienenden Naturmaterialien können sich auch hier das ästhetische Erscheinungsbild, der Farbtonunterschied und die Maserung von Fliese zu Fliese unterscheiden. Um die Variabilität des Produkts besser zu verstehen, raten wir Ihnen, die Bilder mit ausgestatteten Räumen im Kollektionskatalog auf unserer Website [www.casalgrandepadana.de](http://www.casalgrandepadana.de) zu konsultieren. Weitere Informationen können Sie auch bei unseren Vertragshändlern erhalten.





## PESI, MISURE E CONTENUTO DEI COLLI WEIGHT, SIZE AND CONTENTS OF THE PACKING POIDS, DIMENSIONS, CONTENU DES COLIS VERPACKUNGSGRÖSSEN/GEWICHTE

### ECOGRES

		 mm	 x 	 x 	 x 	 x 	 x 	 x 
cm 20x20	7 <sup>7</sup> / <sub>8</sub> "x7 <sup>7</sup> / <sub>8</sub> "	7,3	30	1,20	15,3	72	86,40	1.322
cm 30x60	11 <sup>3</sup> / <sub>4</sub> "x23 <sup>5</sup> / <sub>8</sub> "	8	7	1,26	18,0	48	60,48	1.089
cm 33x33	13"x13"	8	13	1,42	18,0	42	59,64	1.074
cm 41,5x41,5	16 <sup>3</sup> / <sub>8</sub> "x16 <sup>3</sup> / <sub>8</sub> "	8	9	1,55	18,0	48	74,40	1.339

#### BATTISCOPIA B.C. BULLNOSE PLINTHE À BORD ARRONDI STEH SOCKEL

		 x 
cm 8x33	3 <sup>1</sup> / <sub>4</sub> "x13"	30
cm 8x41,5	3 <sup>1</sup> / <sub>4</sub> "x16 <sup>3</sup> / <sub>8</sub> "	25
cm 9x60	3 <sup>1</sup> / <sub>2</sub> "x23 <sup>5</sup> / <sub>8</sub> "	18

#### GRADINO STEP TREAD NEZ DE MARCHE STUFENPLATTE

		 x 
cm 30x60	11 <sup>3</sup> / <sub>4</sub> "x23 <sup>5</sup> / <sub>8</sub> "	6
cm 33x33	13"x13"	13

## CLASSIFICAZIONE DELLE PIASTRELLE DA PAVIMENTO IN BASE ALL'AMBIENTE DI DESTINAZIONE CLASSIFICATION OF THE FLOOR TILES ACCORDING TO THE FINAL DESTINATION CLASSIFICATION DES CARREAUX SELON L'ENTROIT DESTINE KLASSIFIZIERUNG DER BODENFLIESE NACH IHREM VERWENDUNGSZWECK

#### G1 Gruppo 1: Traffico leggero (bagni, camere da letto)

Group 1: Light wear (bathrooms, bedrooms)

Groupe 1: Trafic léger (salles de bains, chambres à coucher)

Gruppe 1: Leichte Beanspruchung (Bade und Schlafzimmer)

#### G2 Gruppo 2: Traffico-medio (appartamenti privati ad esclusione cucine)

Group 2: Medium wear (private apartments, kitchens excluded)

Groupe 2: Trafic moyen (appartements privés sauf cuisines)

Gruppe 2: Beanspruchung (Privatwohnungen außer Küchen)

#### G3 Gruppo 3: Traffico medio-forte (appartamenti, case private)

Group 3: Medium hard wear (flats and private houses)

Groupe 3: Trafic mi-fort (appartements et maisons)

Gruppe 3: Mittlere Beanspruchung (Wohnungen und Privathäuser)

#### G4 Gruppo 4: Traffico forte (ristoranti, uffici, edifici pubblici)

Group 4: Hard wear (restaurants, offices, public buildings)

Groupe 4: Trafic fort (restaurants, bureaux, édifices publics)

Gruppe 4: Starke Beanspruchung (Restaurant, Büros, öffentliche Gebäude)

Nel caso le piastrelle Ecogres siano destinate a rivestimento di pareti chiedere espressamente la fornitura dei jolly eventualmente necessari per il rivestimento degli spigoli.

In case Ecogres-Tiles have to be used as wall coverings, customers can expressly request the supply of mitred tiles for outcorners.

Si les carreaux Ecogres sont destinés à un revêtement mural, les clients peuvent demander expressément la fourniture de carreaux biseautés (jolly)

Für Wandelläge, können die Kunden eine ausdrückliche Lieferung von Jollys (fliesen mit Fase) für kanten eventuell verlangen.

# VARIAZIONI CROMATICHE CHROMATIC VARIATIONS VARIATIONS CHROMATIQUES FARBTONABWEICHUNGEN

Indica il livello di variazione cromatica che sussiste all'interno della stessa collezione fra una piastrella e l'altra.

The scale denotes the level of colour variation that exists between specific tiles in the same collection.

C'est le degré de variation chromatique qui existe entre un carreau et un autre de la même collection.

Das zeigt die Einstufung der chromatischen Variation, die innerhalb den verschiedenen Fliesen der selben Kollektion entsteht.

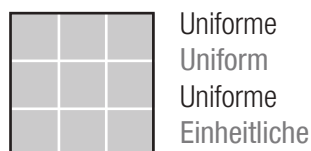

Uniforme  
Uniform  
Uniforme  
Einheitliche

## V1

L'aspetto delle piastrelle è uniforme. Differenze minime fra i prodotti appartenenti al medesimo lotto produttivo.

The appearance of the tiles is uniform. There are minimal differences in products belonging to the same production batch.

L'aspect des carreaux est uniforme. Les différences entre les produits appartenant à un même lot de production sont minimes.

Der optische Aspekt der Fliesen ist einheitlich. Die Unterschiede zwischen Produkten derselben Produktionscharge sind minimal.



Leggera  
Minimal  
Légère  
Leichte

## V2

L'aspetto delle piastrelle presenta leggere ma visibili differenze, che si tratti di segni grafici o sfumature/venature tipiche del materiale naturale di riferimento.

There are subtle yet visible differences in the appearance of the tile, whether these are clear markings or the typical shading/veining of the natural material in question.

L'aspect des carreaux présente des différences légères mais visibles, qu'il s'agisse de marques graphiques ou de nuances/veinures typiques du matériau naturel de référence.

Der optische Aspekt der Fliesen weist leichte aber sichtbare Unterschiede auf, wobei es sich um graphische Zeichnungen oder Schattierungen/Maserungen handelt, die für das natürliche Referenzmaterial typisch sind.



Media  
Medium  
Modérée  
Mittlere

## V3

L'aspetto delle piastrelle presenta variazioni di colore e/o struttura decisi. Questa variabilità cromatica è appositamente studiata in fase di progettazione della collezione per rendere il prodotto il più vicino possibile al materiale naturale di riferimento.

There are clear variations in the colour and/or structure of the tiles. This dynamic colour variation is meticulously planned during the collection design phase in order to make the product as similar as possible to the natural material in question.

L'aspect des carreaux présente des variations de couleur et/ou de structure marquées. Le caractère variable de la couleur est spécialement étudié lors de la conception de la collection pour rendre le produit le plus proche possible du matériau naturel de référence.

Der optische Aspekt der Fliesen weist deutliche Farb- und/oder Strukturunterschiede auf. Diese chromatische Variabilität wurde in der Designphase der Kollektion speziell entwickelt, um das Produkt seinem natürlichen Referenzmaterial so ähnlich wie möglich zu machen.



Accentuata  
Accentuated  
Importante  
Starke

## V4

L'aspetto delle piastrelle presenta variazioni importanti di colore e/o di struttura, rendendole, in alcuni casi, completamente diverse tra loro.

There are significant variations in the colour and/or structure of the tiles. In some cases, one tile can appear completely different to the next.

L'aspect des carreaux présente d'importantes variations de couleur et/ou de structure, ce qui les rend, dans certains cas, complètement différentes entre elles.

Der optische Aspekt der Fliesen weist bedeutende Farb- und/oder Strukturunterschiede auf, durch die sie sich in einigen Fällen vollständig voneinander abheben.

COMPLEMENTI IN ACCIAIO E ALLUMINIO  
ACCESSORIES IN STEEL AND ALUMINIUM  
COMPLÉMENTS EN ACIER ET EN ALUMINIUM  
TECHNISCHE EIGENSCHAFTEN

terminale alluminio



cm 1x30 -  $\frac{3}{8}$ "x1 $\frac{3}{4}$ "

matita alluminio



cm 1,2x30 -  $\frac{1}{2}$ "x1 $\frac{3}{4}$ "

tozzetto alluminio



cm 1,5x1,5 -  $\frac{5}{8}$ "x $\frac{5}{8}$ "

angolo terminale alluminio



cm 1x1 -  $\frac{3}{8}$ "x $\frac{3}{8}$ "

matita acciaio



cm 0,3x60 -  $\frac{1}{4}$ "x2 $\frac{3}{8}$ "

bacchetta alluminio



cm 0,3x60 -  $\frac{1}{4}$ "x2 $\frac{3}{8}$ "

# VOCI DI CAPITOLATO SPECIFICATIONS CAHIER DES CHARGES AUSSCHREIBUNGSTEXTE

## GRANITOGRES

Piastrelle in gres porcellanato antiusura e antimacchia, ingelive, in prima scelta, pressate, *non smaltate e con effetti cromatici ottenuti solo con colorazione in massa*, pienamente vetrificate come da norme UNI EN ISO 14411-G - Gruppo B1a UGL - con assorbimento d'acqua <0,1%, ottenute da miscele selezionate di argille, quarzi e feldspati cotte a temperatura di 1250°C tipo **Granitogres** di **Casalgrande Padana**, con superficie..., formato..., spessore..., colore..., serie..., scelte dalla direzione lavori, per i seguenti locali:

...

Supply of wear-resistant, stain-proof, frost proof, first grade, pressed, *unglazed porcelain stoneware tiles with chromatic effects obtained by full body colouring only*, fully vitrified in accordance with standards UNI EN ISO 14411-G - Group B1a UGL - with <0.1% water absorption. Obtained by selected mixtures of clay, quartz and feldspars fired at 1250°C, type **Granitogres** by **Casalgrande Padana**, with surface textures..., formats..., thickness..., colour..., series..., chosen by the works management for the following places: ...

Fourniture de carreaux de grès cérame résistant à l'usure, aux tâches et au gel, en premier choix, pressés, *non émaillés et à effets chromatiques obtenus seulement par coloration dans la masse*, pleinement vitrifiés conformément aux normes UNI EN ISO 14411-G - Groupe B1a UGL - absorption d'eau <0,1%, obtenus à partir de mélanges sélectionnés d'argiles, quartz et feldspaths cuits à des températures de 1250°C type **Granitogres** de **Casalgrande Padana**, à surface..., format..., épaisseur..., couleur..., série..., choisis par la direction des travaux pour les locaux suivants : ...

Lieferung vor Feinsteinzeugplatten, verschleißfest und fleckenfest, frostsicher, in erster Wahl, gepresst, *unglasiert mit chromatischen Effekten, die sich nur durch die Einfärbung der gesamten Masse erhalten lassen*, voll durchgesintert nach den Normen UNI EN ISO 14411-G - Gruppe B1a UGL - mit Wasseraufnahme <0,1%, erhalten aus ausgesuchten Mischungen von Tonerden, Quarzen und Feldspaten, bei einer Temperatur von 1250°C gebrannt, Typ **Granitogres** von **Casalgrande Padana**, mit Oberflächen..., Format..., Stärke..., Farbe..., Serie..., von der Bauleitung für die folgenden Räume gewählt: ...

## PIETRE NATIVE

Piastrelle in gres porcellanato antiusura e antimacchia, ingelive, in prima scelta, pressate, colorate in massa, pienamente vetrificate come da norme UNI EN ISO 14411-G - Gruppo B1a - con assorbimento d'acqua <0,1%, ottenute da miscele selezionate di argille, quarzi e feldspati cotte a temperatura di 1250°C tipo **Pietre Native** di **Casalgrande Padana**, con superficie..., formato..., spessore..., colore..., serie..., scelte dalla direzione lavori, per i seguenti locali: ...

Supply of wear-resistant, stain proof, frost proof, first grade, pressed, full body coloured porcelain stoneware tiles, fully vitrified in accordance with standards UNI EN ISO 14411-G - Group B1a - with <0.1% water absorption. Obtained by selected mixtures of clay, quartz and feldspars fired at 1250°C, type **Pietre Native** by **Casalgrande Padana**, with surface textures..., formats..., thickness..., colour..., series..., chosen by the works management for the following places: ...

Fourniture de carreaux de grès cérame résistant à l'usure, aux tâches et au gel, en premier choix, pressés, colorés dans la masse, pleinement vitrifiés conformément aux normes UNI EN ISO 14411-G - Groupe B1a - absorption d'eau <0,1%, obtenus à partir de mélanges sélectionnés d'argiles, quartz et feldspaths cuits à des températures de 1250°C type **Pietre Native** de **Casalgrande Padana**, à surface..., format..., épaisseur..., couleur..., série..., choisis par la direction des travaux pour les locaux suivants : ...

Lieferung vor Feinsteinzeugplatten, verschleißfest und fleckenfest, frostsicher, in erster Wahl, gepresst, in der Masse durchgefärbt, voll durchgesintert nach den Normen UNI EN ISO 14411-G - Gruppe B1a - mit Wasseraufnahme <0,1%, erhalten aus ausgesuchten Mischungen von Tonerden, Quarzen und Feldspaten, bei einer Temperatur von 1250°C gebrannt, Typ **Pietre Native** von **Casalgrande Padana**, mit Oberflächen..., Format..., Stärke..., Farbe..., Serie..., von der Bauleitung für die folgenden Räume gewählt: ...

## GRANITOKER

Piastrelle in gres porcellanato, antimacchia e ingelive, in prima scelta colorate in massa, pienamente vetrificate, come da norme UNI EN ISO 14411-G - Gruppo B1a - con assorbimento d'acqua < 0,1%, ottenute da miscele selezionate di argille, quarzi e feldspati cotte a temperatura di 1250°C, tipo **Granitoker** di **Casalgrande Padana** con superficie..., formato..., spessore..., colore..., serie..., scelte dalla direzione lavori, per i seguenti locali: ...

Supply of stain proof, frost proof, first grade, body coloured porcelain stoneware tiles, fully vitrified, in accordance with standards UNI EN ISO 14411-G - Group B1a - with < 0.1% water absorption. Obtained by selected mixtures of clay, quartz and feldspars fired at 1250°C, type **Granitoker** by **Casalgrande Padana**, with surface textures..., formats..., thickness..., colour..., series..., chosen by the works management for the following places: ...

Fourniture de carreaux de grès cérame résistant aux tâches et au gel, en premier choix, colorés dans la masse, pleinement vitrifiés conformément aux normes UNI EN ISO 14411-G - Groupe B1a - absorption d'eau < 0,1%, obtenus à partir de mélanges sélectionnés d'argiles, quartz et feldspaths cuits à des températures de 1250°C type **Granitoker** de **Casalgrande Padana**, à surface..., format..., épaisseur..., couleur..., série..., choisis par la direction des travaux pour les locaux suivants : ...

Lieferung vor Feinsteinzeugplatten, fleckenfest und frostsicher, in erster Wahl, in der Masse durchgefärbt, voll durchgesintert, nach den Normen UNI EN ISO 14411-G - Gruppe B1a - mit Wasseraufnahme < 0,1%, erhalten aus ausgesuchten Mischungen von Tonerden, Quarzen und Feldspaten, bei einer Temperatur von 1250°C gebrannt, Typ **Granitoker** von **Casalgrande Padana** mit Oberflächen..., Format..., Stärke..., Farbe..., Serie..., von der Bauleitung für die folgenden Räume gewählt: ...

## GRESPLUS

Piastrelle in gres porcellanato, antimacchia e ingelive, in prima scelta smaltate, pienamente vetrificate, come da norme UNI EN 14411 ISO 13006 - Gruppo BI a - con assorbimento d'acqua 0,1%, ottenute da miscele selezionate di argille, quarzi e feldspati cotte a temperatura di 1250°C, tipo **Gresplus** di **Casalgrande Padana** con superficie ..., formato ..., spessore ..., colore ..., serie ..., scelte dalla direzione lavori, per i seguenti locali: ...

Supply of stain proof, frost proof, first grade, glazed, fully vitrified porcelain stoneware tiles, in accordance with standards UNI EN 14411-G ISO 13006 - Group BIa - with 0.1% water absorption. Obtained by selected mixtures of clay, quartz and feldspars fired at 1250°C, type **Gresplus** by **Casalgrande Padana**, with surface textures ..., formats ..., thickness ..., colour ..., series ..., chosen by the works management for the following places: ...

Fourniture de carreaux de grès cérame résistant aux tâches et au gel, en premier choix, émaillés, pleinement vitrifiés conformément aux normes UNI EN 14411-G ISO 13006 - Groupe BI a - absorption d'eau 0,1%, obtenus à partir de mélanges sélectionnés d'argiles, quartz et feldspaths cuits à des températures de 1250°C type **Gresplus** de **Casalgrande Padana**, à surface ..., format ..., épaisseur ..., couleur ..., série ..., choisis par la direction des travaux pour les locaux suivants : ...

Lieferung vor Feinsteinzeugplatten, fleckenfest und frostsicher, in erster Wahl, glasiert, voll durchgesintert, nach den Normen UNI EN 14411-G ISO 13006 - Gruppe BIa - mit Wasseraufnahme 0,1%, erhalten aus ausgesuchten Mischungen von Tonerden, Quarzen und Feldspaten, bei einer Temperatur von 1250°C gebrannt, Typ **Gresplus** von **Casalgrande Padana** mit Oberflächen ..., Format ..., Stärke ..., Farbe ..., Serie ..., von der Bauleitung für die folgenden Räume gewählt: ...

## ECOGRES

Piastrelle in monocottura in pasta bianca, in prima scelta, pressate, smaltate, tipo **Ecogres** di **Casalgrande Padana**, come da norme UNI EN 14411 ISO 13006 - Gruppo BIb GL con superficie ..., formato ..., spessore ..., colore ..., serie ..., scelte dalla direzione lavori, per i seguenti locali: ...

**Casalgrande Padana's Ecogres** first-choice single-fired, white body, pressed enamelled tiles comply with EN 14411 and ISO 13006 - Group BIb GL. Surface: ...; format: ...; thickness ...; colour: ...; series: ..., chosen by Construction Supervision for the following rooms: ...

Carreaux en monocuisson à pâte blanche, de premier choix, pressés, émaillés, type **Ecogres** de **Casalgrande Padana**, conformément aux normes UNI EN 14411 ISO 13006 - Groupe BIb GL avec surface ..., format ..., épaisseur ..., couleur ..., série ..., choisis par le maître d'ouvrage, pour les locaux suivants : ...

Einbrandfliese weißscherbig, erste Wahl, gepresst, lackiert, Typ **Ecogres** von **Casalgrande Padana**, konform mit DIN EN 14411 / ISO 13006 - Gruppe BIb GL Oberfläche: ...; Format: ...; Stärke: ...; Farbe: ...; Serie: ...; ausgewählt von der Bauleitung für folgende Räume: ...

## POSA E MANUTENZIONE

### POSA IN OPERA

La riuscita di un pavimento è dovuta non solo alla qualità delle piastrelle, ma a tutto un insieme di elementi (sottofondo, strato legante, giunti di dilatazione, ecc.) che costituiscono un vero e proprio sistema. Ecco perché le operazioni di posa sono da considerarsi importanti tanto quanto la scelta delle piastrelle. È comunque compito del progettista stabilire, in funzione della struttura e della destinazione d'uso del piano di calpestio, il corretto modo di applicazione delle piastrelle e il tipo di piastrella da utilizzare. Le piastrelle **Casalgrande Padana** non si differenziano, per quanto riguarda le operazioni di posa, da una qualsiasi altra ceramica e si può quindi seguire sia il sistema tradizionale con malta cementizia, che quello con collanti o adesivi.

È consigliabile ricorrere ad un sistema di posa con adesivo, da prescrivere in funzione dell'ambiente di destinazione, della tipologia e delle caratteristiche del supporto di posa, del formato considerato e dei carichi statici/dinamici agenti sulla piastrellatura ceramica. È inoltre necessario verificare, prima di procedere alla posa, che il supporto possieda idonee caratteristiche per l'incollaggio della ceramica, quali: stabilità e regolarità dimensionale, rigidità, assenza di fessurazioni, pulizia e integrità superficiale, assenza di umidità in eccesso e/o di agenti contaminanti. Prima di iniziare le operazioni di posa di una qualsiasi superficie si raccomanda di accertarsi che la partita di grès sia adeguata e sufficiente per quantità, tono e calibro, a quella necessaria. Si dovranno poi seguire tutte le norme e le precauzioni che sono alla base di una corretta esecuzione del lavoro (preparazione del sottofondo, composizione della malta o dei collanti, tempi di maturazione, posizionamento dei giunti di dilatazione, battitura, ecc.).

Se per ambienti di grandi dimensioni è assolutamente necessario posizionare i giunti con regolarità, per piccoli ambienti è sufficiente lasciare un leggero stacco fra piastrellato e muri perimetrali. Sarà poi il battiscopa a coprire lo stacco dando un aspetto di finitura. Evitare il transito sul pavimento per almeno 2/3 giorni dopo la posa.

In caso di necessità di transito si dovrà predisporre un tavolato appoggiato sul pavimento.

Successivamente alla posa si raccomanda di proteggere adeguatamente il pavimento sino al termine del cantiere in modo tale da evitare danni causati da sostanze abrasive o da altri agenti dannosi.

Le piastrelle **Casalgrande Padana** pur essendo materiale molto resistente, possono essere sagomate o perforate per l'installazione di impianti tecnico sanitari, utilizzando una attrezzatura adeguata.

Un pavimento o rivestimento murale **Casalgrande Padana** Padana sia nella versione naturale che lappata, lucida, o levigata, è sinonimo di bellezza, durata e resistenza nel tempo.

La sua manutenzione non richiede particolari cure se non l'attenersi alle seguenti norme di pulizia.

### PRIMA PULIZIA

Ha lo scopo di eliminare ogni traccia di cemento o stucco conseguente alla chiusura dei giunti. Si esegue normalmente una sola volta prima dell'utilizzo del pavimento/rivestimento e deve essere obbligatoriamente eseguita dopo la posa in opera e prima dell'uso del pavimento/rivestimento.

Procedere nel modo seguente:

1. Spazzare il pavimento/rivestimento raccogliendo lo sporco grossolano.
2. Inumidire con acqua la superficie affinché le fughe vengano impregnate e pertanto protette dall'azione corrosiva del detergente a componente acido (decalcificante).
3. Stendere il detergente (vedi nota **A**) nella concentrazione (rapporto di miscelazione con l'acqua) indicata dal produttore, applicandolo con una spazzola manuale o motorizzata.  
Per la serie Metallica utilizzare detergenti molto diluiti (diluizione 1-5, 1 parte di acido e 5 parti di acqua) e assicurarsi in particolare un abbondante risciacquo seguito da asciugatura completa del pavimento. Evitare che il detergente acido venga a contatto con componenti di acciaio, alluminio e marmo naturale adiacenti al pavimento/rivestimento.
- 4) Durante il tempo d'azione, che deve essere stabilito in relazione allo stato del pavimento, strofinare lo sporco più ostinato (e raschiare eventuali residui di malta, stucco, etc...).
- 5) Sciacquare il pavimento/rivestimento con acqua e raccogliere subito l'acqua sporca (manualmente o con un apparecchio lavasciuga).

(Per la serie Metallica utilizzare detergenti molto diluiti - diluizione 1 a 5, 1 parte di acido e 5 parti di acqua - e procedere con un abbondante risciacquo per eliminare ogni residuo di acido sulla superficie).

Se la prima pulizia viene eseguita dopo che il pavimento/rivestimento è già stato usato, sarà bene, prima dell'applicazione del detergente a base acida, togliere con appositi detersivi alcalini (sgrassanti) eventuali presenze di sostanze grasse o simili (vedi Pulizia ordinaria).

L'operazione di prima pulizia, se ritenuto necessario, può essere ripetuta.

### Superficie levigata, lucida e lappata

Com'è noto tutte le superfici lucide subiscono con l'uso un processo di opacizzazione. Nel caso dei prodotti Casalgrande Padana, grazie alle peculiari caratteristiche tecniche, questo processo è più lento rispetto a qualsiasi altro materiale naturale (marmo, granito, pietre...). Per conservare tuttavia il più a lungo possibile la lucentezza originale del pavimento è bene proteggere l'ingresso del locale pavimentato, specie se questo è in diretta comunicazione con ambienti esterni, con uno zerbino che possa trattenere il più possibile polveri o altre sostanze abrasive fuori dal pavimento.

Una leggera diminuzione della lucentezza, a seguito del primo lavaggio acido del pavimento, deve essere considerata normale, perché dovuta alla eliminazione dei residui degli abrasivi utilizzati nella lavorazione della superficie.

**A.** Alcuni detergenti consigliati per eliminare i residui di stucco:

#### **Fughe realizzate con stucco cementizio detergenti a componente acida (decalcificanti)**

Deterprimo plus (Casalgrande Padana), Deterdek (Fila), Keranet (Mapei), Deltaplus (Kerakoll), Solvacid (Geal) o simili (seguire istruzioni del produttore del detergente).

#### **Fughe realizzate con stucco epossidico detergenti a componente alcalina**

Fuga-Soap Eco (Kerakoll), Kerapoxy Cleaner (Mapei), Tile Cleaner (Faber), CR10 (Fila), Lithofin Resin-Ex (Lithofin), Eposolv (Geal) o simili (seguire istruzioni del produttore del detergente).

### PULIZIA ORDINARIA

Per la pulizia di tutti i giorni è sufficiente lavare il pavimento/rivestimento con acqua e aggiunta di normali prodotti detergenti adatti a pulire superfici ceramiche (per i rivestimenti utilizzare detergenti in gel).

Assicurarsi che i detergenti non contengano sostanze cerose; la superficie dei prodotti installation operations, **Casalgrande Padana**, essendo praticamente inassorbente, non richiede l'applicazione di cere e/o prodotti siliconici di protezione che, al contrario, non debbono mai essere usati (possono creare un film superficiale che andrebbe a modificare le caratteristiche naturali del grès porcellanato).

In presenza di macchie persistenti e difficili da togliere con la pulizia ordinaria, intervenire con impiego di detergenti più concentrati lasciando agire gli stessi per un adeguato intervallo di tempo e, successivamente, strofinare con adeguata intensità, fino a ricondurre le piastrelle all'aspetto originario. Al riguardo è opportuno segnalare che il grès è resistente a qualsiasi sostanza chimica, **eccezion fatta per l'acido fluoridrico che attacca tutti i prodotti ceramici e che, quindi, non deve mai essere utilizzato.**

Per la pulizia di pavimenti in aree pubbliche si consiglia di intervenire dopo la chiusura dei locali, affinché il pavimento alla riapertura sia asciutto; in alternativa isolare il pavimento pulito fino alla sua completa asciugatura.

Per i locali di maggiore estensione è opportuno disporre di macchine lavasciuga, per assicurare una perfetta pulizia e igienicità.

**Il pavimento deve essere considerato pulito quando riacquista il suo aspetto originario!**

### Superfici in rilievo (antislip)

Queste superfici, impiegate normalmente in ambienti industriali o di lavoro, richiedono particolari accorgimenti per la loro manutenzione.

Per i locali di maggiore estensione è opportuno disporre di macchine lavasciuga, per assicurare una perfetta pulizia e igienicità.

Altro metodo usato in questo tipo di pavimenti è quello mediante idropulitrice.

# INSTALLATION AND MAINTENANCE

## INSTALLATION

The successful installation of floors depends not only on the quality of tiles but on a combination of factors (bedding, binding layer, expansion joints, etc.) that constitute a real system.

That is why installation operations are to be considered as important as the choice of tiles. However, based on the structure and purpose of the flooring surface, the designer is still responsible for defining the correct procedure to lay the tiles and selecting the ones to be employed. When it comes to installation operations, **Casalgrande Padana** do not differ from any other type of ceramic: either the traditional procedure envisaging cement mortar or the procedure envisaging glues and adhesives may be resorted to. We recommend using an installation system with an adhesive according to the intended use of the room, type and characteristics of the substrate, and size in consideration of the static/dynamic loads on the ceramic tiles.

You must first ensure that the substrate has suitable characteristics for glueing ceramics, such as stability and dimensional regularity, rigidity, absence of cracks, clean and intact surface, and absence of excess moist and/or contaminants.

Before starting the installation operations of any surface, we recommend you make sure that the stoneware batch is adequate and sufficient in terms of quantity, tone and calibration.

Moreover, all necessary norms and precautions need to be implemented for the correct completion of the work (bedding preparation, composition of mortar or adhesives, maturing period, positioning expansion joints, ramming, etc.).

If in case of large environments joints must be positioned at regular intervals, in small environments a small gap between the tiles and perimeter walls is sufficient: the skirting board will cover the gap and provide the finishing effect.

Avoid walking on the floor for at least 2/3 days after installation. If walking on the floor is necessary, lay wooden planks on the surface.

After laying, it is recommended to adequately protect the floor until finished in order to avoid damage caused by abrasive substances or other harmful agents.

Even though **Casalgrande Padana** tiles are very resilient material, they can be shaped or perforated to install technical and sanitary systems, using appropriate equipment.

## FIRST CLEAN

A **Casalgrande Padana** flooring or wall covering, whether natural, lapped, lucida or polished, is synonym with beauty, strength and a long life. These surfaces are low maintenance and only need be cleaned as described below.

The purpose of first-time cleaning is to remove any trace of cement or plaster used to close the joints.

The flooring/wall covering is normally cleaned once before use. This must be done after installation and before use.

Proceed as follows:

1. Sweep the floor/covering to remove the coarser dirt.
2. water so as to soak the joints, thereby protecting them from the corrosive action of the acid detergent (descaling product).
3. Apply the detergent (see note A) in the concentration (water mixing ratio) indicated by the manufacturer using a manual or motorised brush. With regards to the Metallica series, use very diluted detergents (1-5 dilution i.e., 1 part acid to 5 parts water), rinse thoroughly, and leave the floor to dry completely.  
Avoid any contact between the acid detergent and the steel, aluminium, and natural marble components near the flooring/wall covering.
4. Leave it as long as needed depending on the condition of the floor, then rub any stubborn dirt away (such as mortar, plaster, etc. ...).
5. Rinse the flooring/covering with water and mop up the dirty water immediately (manually or with a washer/drier).

(With regards to the Metallica series, use highly diluted detergents – 1-5 dilution i.e., 1 part acid to 5 parts water – and rinse thoroughly to remove any acid residue from the surface).

If the flooring/wall covering is cleaned for the first time after being used, it is important to use appropriate alkaline detergents (degreasing agents) before applying the acid detergent to remove any greasy or similar substance (see Routine Cleaning).

If necessary, you can repeat the first-time cleaning operations described above.

## Polished, lucida and lapped surfaces

All polished surfaces tend to become more opaque with use.

Because of its outstanding technical properties, with **Casalgrande Padana** products this process is slower than for any other natural material (marble, granite, stone, etc.). However, to protect the floor's shine for as long as possible, it's important to protect the entrance to the floored room, especially if it has an adjoining outdoor area, with a doormat that can keep as much dust or abrasive substances as possible off the floor.

A slight loss of shine after the first acid wash must be considered normal, as it is due to the removal of the abrasive residues used for processing the surface.

- A. Here are a few detergents recommended for removing plaster residues:

### Cement plaster joints – acid detergents (descaling products)

Deterprimo Plus (**Casalgrande Padana**), Deterdek (Fila), Keranet (Mapei), Deltaplus (Kerakoll), Solvacid (Geal) or similar detergents (follow the manufacturer's instructions).

### Epoxy plaster joints – alkaline detergents

Fuga-Soap Eco (Kerakoll), Kerapoxy Cleaner (Mapei), Tile Cleaner (Faber), CR10 (Fila), Lithofin Resin-Ex (Lithofin), Eposolv (Geal) or similar detergents (follow the manufacturer's instructions).

## ROUTINE CLEANING

For everyday cleaning, all you have to do is wash the flooring/wall covering with water and normal neutral detergents suitable for ceramic surfaces (for wall coverings use a neutral gel detergent gel).

Make sure that the detergents do not contain waxy substances.

The surface of installation operations, **Casalgrande Padana** products are practically non-absorbent; therefore, the use of wax and/or silicone cleaners is not required. These should never be used, as they create a superficial film that changes the natural characteristics of porcelain stoneware. Should there be any stubborn stain that cannot be removed by routine cleaning, use a more concentrated detergent and leave it on for long enough, then rub harder until the tiles are back to their original condition. Note that porcelain stoneware is resistant to any chemical, **except hydrofluoric acid, which eats into any ceramic, so it must never be used.**

Floors of public areas should be cleaned when the place is closed, so the floor will be dry when it reopens; otherwise, fence off the cleaned floor until perfectly dry.

For larger places, use a washer/drier to ensure perfect cleanliness and hygiene.

**The flooring is to be considered clean when it returns to its original appearance!**

## Anti-slip flooring

These surfaces are normally used in industrial or work environments and require a few extra measures for their maintenance.

For larger places, use a washer/drier to ensure perfect cleanliness and hygiene.

These floors can also be cleaned using a pressure washer.

## POSE ET ENTRETIEN

### POSE

Un bon sol dépend non seulement de la qualité des carreaux, mais aussi de toute une série d'éléments qui constituent un seul tout (couche de fond, couche d'un agent liant, joints de dilatation, etc.). C'est pourquoi les opérations de pose sont tout aussi importantes que le choix du carrelage. Il appartient à l'architecte d'établir le type de carrelage à utiliser en fonction du lieu et de l'utilisation du sol ainsi que la meilleure méthode de pose des carreaux. En ce qui concerne les opérations de pose, les séries **Casalgrande Padana** ne sont pas différentes des autres carreaux céramiques et il est donc possible de suivre la méthode traditionnelle en utilisant du mortier de ciment ou d'utiliser des colles ou autres produits adhésifs. Il est conseillé de recourir à un système de pose avec de l'adhésif, à adopter en fonction de l'environnement de destination, de la typologie et des caractéristiques du support de pose, du format envisagé et des charges statiques/dynamiques appliquées sur le carrelage en céramique. Avant de procéder à la pose, il est également nécessaire de s'assurer que le support possède les caractéristiques appropriées pour le collage de la céramique. Ces caractéristiques sont les suivantes : stabilité et régularité dimensionnelle, rigidité, absence de fissures, nettoyage et intégrité de la surface, absence d'excès d'humidité et/ou d'agents de contamination. Avant de commencer les opérations de pose, il est recommandé de vérifier que les lots de carreaux en grès correspondent bien à la quantité, à la couleur et au calibre nécessaires.

Il faut ensuite respecter toutes les normes et les précautions qui sont à la base de la bonne exécution des travaux (préparation de la couche de fond, composition du mortier ou des colles, positionnement des joints de dilatation, nivellement à l'aide du maillet, temps de séchage, etc.). Pour les grandes surfaces, il est absolument nécessaire de positionner les joints avec la plus grande régularité, tandis que pour les petites surfaces, il suffira de laisser un léger écart entre le carrelage et les murs périmétraux. Ce seront ensuite les plinthes qui couvriront l'écart pour donner l'aspect de finition. Après la pose, éviter de marcher sur le sol pendant au moins 2 ou 3 jours. Si le passage s'avère nécessaire, il faudra poser des planches sur le sol.

Après la pose, il est recommandé de protéger le sol de manière adéquate jusqu'à la fin des travaux afin d'éviter tout dommage pouvant être causé par des substances abrasives ou par d'autres agents nocifs.

Même si les carreaux des séries **Casalgrande Padana** sont extrêmement résistants, ils peuvent être façonnés et perforés pour installer les équipements technico-sanitaires en utilisant les outils appropriés.

Les revêtements de sol et de mur de installation operations, **Casalgrande Padana**, qu'ils soient en version naturelle, poncée, brillante ou polie, sont synonymes de beauté, de solidité et de durabilité.

Ils n'exigent aucune opération d'entretien particulière, il suffit de suivre les conseils d'entretien suivants :

### PREMIER NETTOYAGE

Son but est d'éliminer toute trace de ciment ou de mortier-colle après le jointolement. Cette opération est généralement effectuée une seule fois avant d'utiliser le revêtement sol/mur, et il faut obligatoirement l'effectuer après la pose et avant toute utilisation du revêtement sol/mur. Procéder de la manière suivante :

1. Balayer/épousseter le revêtement sol/mur en éliminant toutes traces d'impuretés.
2. Humidifier la surface avec de l'eau de manière à bien imprégner les joints afin qu'ils soient ainsi bien protégés de l'action corrosive du nettoyant acide (décalcifiant).
3. Respecter la concentration (quantité à diluer dans l'eau) indiquée par le fabricant pour l'utilisation du produit nettoyant, et appliquer le produit (voir note **A**) à l'aide d'une brosse manuelle ou motorisée. Pour la série Metallica, utiliser des nettoyants acides après les avoir bien dilués dans l'eau (rapport 1-5, 1 part d'acide et 5 parts d'eau), puis veiller à bien rincer et à essuyer complètement le sol. Veillez à ce que le nettoyant acide n'entre pas en contact d'éléments en acier et en aluminium, ou d'éléments en marbre naturel placés à proximité du revêtement sol/mur.
4. Pendant le temps d'action du produit, à établir en fonction de l'état du sol, frotter les taches les plus persistantes (et racler d'éventuels résidus de mortier, de mortier-colle, etc.).
5. Rincer le revêtement sol/mur avec de l'eau, puis éliminer immédia-

ment l'eau sale (à la main ou avec un appareil de nettoyage à aspiration d'eau).

**(Pour la série Metallica, utiliser des nettoyants acides après les avoir bien dilués dans l'eau (rapport 1-5, 1 part d'acide et 5 parts d'eau), puis veiller à bien rincer pour éliminer tout résidu d'acide sur la surface).**

Si le premier nettoyage est effectué après avoir utilisé le revêtement sol/mur, avant d'appliquer le nettoyant acide, il est conseillé d'éliminer toute éventuelle trace de substance grasse ou similaire en utilisant les nettoyants alcalins (dégraissants) prévus à cet effet (voir Nettoyage ordinaire). S'il y a lieu, répéter cette première opération de nettoyage.

### Surfaces polies, brillantes et poncées

Il est notoire que les surfaces brillantes ont tendance à se ternir au fil du temps. Dans le cas des produits Casalgrande Padana, leurs caractéristiques techniques particulières permettent de ralentir ce processus par rapport à tout autre matériau naturel (marbre, granit, pierres, etc.). Pour conserver plus longtemps l'éclat original du sol, il est conseillé de protéger l'entrée de la pièce avec un tapis ou avec un paillason en cas de pièces donnant sur l'extérieur, en empêchant ainsi que la poussière et/ou d'autres substances abrasives ne puissent se déposer sur le sol. Après le premier lavage avec le produit acide, une légère diminution de la brillance doit être considérée normale, étant due à l'élimination des résidus abrasifs utilisés lors du traitement de surface effectué en usine.

**A.** Voici certains nettoyants conseillés pour éliminer les résidus de mortier-colle :

#### **Joint réalisés en mortier-ciment nettoyants acides (décalcifiants)**

Deterprimo plus (Casalgrande Padana), Deterdek (Fila), Keranet (Mapei), Deltaplus (Kerakoll), Solvacid (Geal) ou produits similaires (suivre les instructions du fabricant du produit nettoyant).

#### **Joint réalisés en mortier-époxy – nettoyants alcalins**

Fuga-Soap Eco (Kerakoll), Kerapoxy Cleaner (Mapei), Tile Cleaner (Faber), CR10 (Fila), Lithofin Resin-Ex (Lithofin), Eposolv (Geal) ou produits similaires (suivre les instructions du fabricant du produit nettoyant).

### NETTOYAGE ORDINAIRE

Pour le nettoyage quotidien, il suffit de laver le revêtement sol/mur avec de l'eau en y diluant des produits nettoyants adaptés aux surfaces en céramique (pour les murs, utiliser des produits nettoyants sous forme de gel). S'assurer que les produits nettoyants ne contiennent pas de substances à base de cire ; la surface des produits installation operations, **Casalgrande Padana** étant pratiquement non absorbante, il n'y a aucun besoin de passer ni cire ni autre produit similaire de protection à base de silicone ; bien au contraire, ces produits ne doivent jamais être utilisés (ils pourraient créer un film superficiel susceptible de modifier les caractéristiques naturelles du grès cérame).

Néanmoins, en cas de taches persistantes et difficiles à éliminer par un nettoyage ordinaire, utiliser un produit nettoyant plus puissant en le laissant agir pendant un temps adéquat, puis frotter énergiquement jusqu'à ce que le carrelage retrouve son aspect d'origine. Il est intéressant de signaler que le grès résiste aux substances chimiques, **à l'exception de l'acide fluorhydrique qui attaque tous les produits céramiques et qui ne doit donc jamais être utilisé.**

Pour le nettoyage de lieux publics, il est conseillé d'effectuer l'entretien après la fermeture des locaux, afin que le sol soit bien sec avant la réouverture. En alternative, isoler le sol nettoyé jusqu'à ce qu'il soit complètement sec.

Pour le nettoyage des sols sur de grandes surfaces, il convient d'utiliser des autolaveuses, pour garantir une hygiène et un nettoyage parfaits.

**Le sol doit être considéré comme propre lorsqu'il retrouve son aspect d'origine !**

### Surfaces en relief (antidérapant)

Pour l'entretien de ces surfaces, employées habituellement dans des environnements industriels ou professionnels, il convient de prendre des précautions particulières.

Pour les grandes surfaces, il convient d'utiliser des autolaveuses pour garantir un nettoyage optimal et une hygiène parfaite.

Une autre méthode consiste à utiliser des machines de nettoyage à l'eau sous pression.



# VERLEGUNG UND PFLEGE

## VERLEGUNG

Das gute Gelingen eines Bodenbelags hängt nicht nur von der Qualität der Fliesen ab, sondern von einer ganzen Reihe an Elementen (Untergrund, Bindschicht, Dehnungsfugen, usw.), die ein Gesamtsystem bilden. Deshalb sind die Verlegungsarbeiten genauso wichtig, wie die Wahl der Fliesen. Der Planer hat die Aufgabe, je nach Struktur und Bestimmungszweck der Bodenfläche die korrekte Fliesen-Verlegungsmethode und die Art der einzusetzenden Fliesen zu bestimmen. **Casalgrande Padana** unterscheiden sich in Bezug auf die Verlegungsarbeiten nicht von anderen Keramikprodukten, so dass die Verlegung sowohl auf traditionelle Art mit Zementmörtel als auch mit Leimen oder Klebstoffen erfolgen kann. Es wird empfohlen, ein Verlegesystem mit Klebstoff zu verwenden, das der vorgesehenen Umgebung, der Art und den Eigenschaften des Untergrunds, am gewünschten Format und der auf die Fliesen einwirkende statischen bzw. dynamische Kraft vorgeschrieben wird. Vor der Verlegung ist eine Prüfung erforderlich, der Untergrund die entsprechenden Eigenschaften für eine Verklebung von Keramikfliesen besitzt. Entscheidend hierfür sind ein gleichbleibendes, regelmäßiges Flächenmaß, Steifigkeit, keine Risse, saubere Oberfläche frei von Fehlstellen, keine verbleibende Feuchtigkeit und/oder Schadstoffverunreinigungen.

Vor Beginn der Verlegung auf jeglichen Oberflächen ist unbedingt sicher zu stellen, dass das Steinzeug geeignet ist und in der notwendigen Menge und im gewünschten Farbton und Werkmaß zur Verfügung steht. Es müssen zudem alle Vorschriften und Vorkehrungen beachtet werden, die einer korrekten Ausführung der Arbeiten zu Grunde liegen (Vorbereitung des Untergrundes, Zubereitung des Mörtels oder der Kleber, Abbindezeiten, Position der Dehnungsfugen, Anklopfen, usw.). In großflächigen Bereichen sind unbedingt regelmäßig Dehnungsfugen einzuplanen, während es in kleinen Bereichen genügt, ein wenig Abstand zwischen Fliesenfläche und Randmauern zu lassen. Mit der Sockelleiste wird dieser Abstand dann abgedeckt, um den Boden fertig zu stellen. Nach dem Verlegen darf der Boden mindestens 2-3 Tage nicht begangen werden. Falls ein Begehen notwendig sein sollte, müssen zuvor Planken auf den Boden gelegt werden. Nach der Verlegung sollte der Bodenbelag bis zum Abschluss der Bauarbeiten angemessen geschützt werden, um Beschädigungen durch abrasive Substanzen oder andere schädliche Agentien zu vermeiden. Obwohl es sich bei den Platten von **Casalgrande Padana** um hochresistente Materialien handelt, lassen sie sich für die Installation von technisch-sanitären Anlagen unter Verwendung geeigneter Geräte zuschneiden oder bohren.

Ein Fußboden oder eine Wandverkleidung von **Casalgrande Padana** ist sowohl in der natürlichen wie auch anpolierten, polierten oder geschliffenen Ausführung Ausdruck von Schönheit, Widerstandsfähigkeit und Langlebigkeit. Die Instandhaltung solcher Beläge verlangt keine besonderen Pflegemaßnahmen, sondern lediglich die Beachtung der folgenden Reinigungsverfahren.

## ERSTREINIGUNG

Sie dient dazu, nach der Verlegung jegliche Spur von Zement oder Fugenmörtel zu entfernen.

Normalerweise wird sie nur einmal vor der Verwendung des Fußbodens bzw. der Wandverkleidung durchgeführt und sollte nach der Verlegung und vor der Nutzung vorgenommen werden. Gehen Sie dazu folgendermaßen vor:

1. Den Fußboden/die Verkleidung fegen und den groben Schmutz entfernen.
2. Die Oberfläche mit Wasser befeuchten, um die Fugen zu imprägnieren und somit vor der ätzenden Wirkung des säurehaltigen Reinigungsmittels (Kalklöser) zu schützen.
3. Das Reinigungsprodukt (*siehe Anmerkung A*) in der vom Hersteller vorgegebenen Konzentration (Mischverhältnis mit Wasser) mit einer Handbürste oder einer motorbetriebenen Bürste auftragen.  
Für die Metallica-Serie unbedingt stark verdünnte Reinigungsmittel (Mischverhältnis 1:5, 1 Teil Säure und 5 Teile Wasser) verwenden; dabei muss ganz besonders auf ein ausreichendes Nachspülen und eine vollständige Trocknung des Bodens geachtet werden. Den Kontakt des säurehaltigen Reinigungsmittels mit etwaigen Komponenten aus Stahl, Aluminium und Naturmarmor, die am Fußboden/an der Wandverkleidung angrenzen, vermeiden.
4. Während der Wirkzeit, die je nach Zustand des Fußbodens festzulegen ist, den hartnäckigsten Schmutz abreiben (und etwaige Mörtel- und Kittrückstände usw. abkratzen).

5. Den Fußboden/die Wandverkleidung mit Wasser abspülen und das Schmutzwasser sofort aufnehmen (von Hand oder mit einer Bodenreinigungsmaschine).

(Für die Metallica-Serie unbedingt stark verdünnte Reinigungsmittel – Mischverhältnis 1:5, 1 Teil Säure und 5 Teile Wasser – verwenden und dabei ganz besonders auf ein ausreichendes Nachspülen achten, um alle Spuren von Säure auf der Oberfläche zu beseitigen).

Wenn die Erstreinigung erst nach der Benutzung des Fußbodens/der Wandverkleidung erfolgt, müssen vor der Anwendung des säurehaltigen Reinigungsmittels etwaige Fette oder ähnliche Stoffe mit geeigneten Alkalireinigern (Fettlösern) entfernt werden (siehe Normale Reinigung). Falls erforderlich, kann die Erstreinigung wiederholt werden.

## Geschliffene, polierte und anpolierte Oberflächen

Bekanntlich werden alle glänzenden Oberflächen im Laufe der Zeit matt. Dank ihrer besonderen technischen Eigenschaften erfolgt dieser Vorgang bei den Produkten von Casalgrande Padana im Vergleich zu allen anderen natürlichen Materialien (Marmor, Granit, Naturstein, ...) langsamer. Um den ursprünglichen Glanz des Fußbodens jedoch so lange wie möglich zu bewahren, ist es ratsam, den Eingangsbereich, vor allem wenn dieser direkt nach außen führt, mit einer Fußmatte zu schützen, um Staub oder andere Schleifmittel so gut wie möglich vor dem Boden abzufangen. Ein leichter Glanzverlust infolge der ersten säurehaltigen Wäsche des Fußbodens ist als normal zu betrachten, da er auf die Entfernung der Rückstände der für die Oberflächenbearbeitung verwendeten Schleifmittel zurückzuführen ist.

- A. Einige empfohlene Reinigungsmittel zur Entfernung von Mörtelresten:

### Verfugung mit Zementfugenmörtel säurehaltige Reinigungsmittel (Kalklöser)

Deterprimo plus (Casalgrande Padana), Deterdek (Fila), Keranet (Mapei), Deltaplus (Kerakoll), Solvacid (Geal) oder ähnliche Mittel (die Angaben des Reinigungsmittelherstellers beachten).

### Verfugung mit Epoxidfugenmörtel alkalische Reinigungsmittel

Fuga-Soap Eco (Kerakoll), Kerapoxy Cleaner (Mapei), Tile Cleaner (Faber), CR10 (Fila), Lithofin Resin-Ex (Lithofin), Eposolv (Geal) oder ähnliche Mittel (die Angaben des Reinigungsmittelherstellers beachten).

## NORMALE REINIGUNG

Für die Alltagsreinigung genügt es, den Fußboden/die Wandverkleidung mit Wasser und normalen Reinigungsmitteln für Keramikflächen zu reinigen (für Wandverkleidungen Gels verwenden). Da die Oberflächen der Produkte von installation operations, **Casalgrande Padana** praktisch nicht aufnahmefähig sind, müssen für ihren Schutz keine Wachse und/oder silikonhaltige Produkte aufgetragen werden. Ganz im Gegenteil sollten diese niemals verwendet werden (sie können einen Oberflächenfilm bilden, der die natürlichen Eigenschaften des Feinsteinzeugs verändert). Bei beständigen und schwer entfernbaren Flecken, die sich nicht mit einer normalen Reinigung beseitigen lassen, können konzentriertere Reinigungsmittel verwendet werden; diese sollte man für eine angemessene Zeit einwirken lassen und dann angemessen kräftig abreiben, bis die Platten wieder ihr ursprüngliches Aussehen zurückerhalten. Wir weisen darauf hin, dass Steinzeug gegen alle chemischen Mittel beständig ist, mit Ausnahme von Fluorwasserstoffsäure, **die alle Keramikprodukte angreift und daher nicht verwendet werden darf**. In öffentlichen Bereichen sollte die Reinigung nach der Schließzeit vorgenommen werden, damit der Boden bei der Wiedereröffnung trocken ist; anderenfalls sollte der gereinigte Bereich bis zur kompletten Trocknung abgesperrt werden. Für große Räumlichkeiten ist der Einsatz von Reinigungsmaschinen empfehlenswert, um eine perfekte Reinigung und Hygiene sicherzustellen.

**Der Bodenbelag gilt als sauber, wenn er wieder sein ursprüngliches Aussehen hat!**

## Reliefoberflächen (rutschfest)

Diese Oberflächen, die in der Regel im Bereich der Industrie oder an Arbeitsplätzen verwendet werden, erfordern für ihre Pflege besondere Maßnahmen.

Für große Räumlichkeiten ist der Einsatz von Reinigungsmaschinen empfehlenswert, um eine perfekte Reinigung und Hygiene sicherzustellen. Eine andere Methode, die für diese Art von Bodenbelag verwendet werden kann, ist die Reinigung mit einem Hochdruckreiniger.



CASALGRANDE  
PADANA  
Pave your way

**Casalgrande Padana**

si riserva il diritto di apportare al presente catalogo variazioni e/o correzioni sulla base dell'evoluzione tecnologica e della ricerca della ottimizzazione del prodotto.

I colori e l'estetica dei prodotti sono quanto più possibile vicini a quelli reali, nei limiti dei processi di stampa.

**Casalgrande Padana**

reserves the right to make changes and/or corrections to this catalogue based on the technological developments and product optimisation.

The colour and appearance of the products as shown are as close as possible to the real thing, inside the limitations of the printing process.

**Casalgrande Padana**

se réserve le droit d'apporter des modifications et/ou des corrections au présent catalogue, en fonction de l'évolution technologique et de la recherche en matière d'optimisation du produit. Les couleurs et l'apparence des produits sont aussi fidèles à la réalité que possible, dans les limites des processus d'impression.

**Casalgrande Padana**

behält sich das Recht vor, auf Grundlage der technischen Entwicklung und der Erforschung der Produktoptimierung Änderungen und/ oder Korrekturen an diesem Katalog vorzunehmen. Die Farben und das Aussehen der Produkte entsprechen den tatsächlichen Produkten, soweit dies im Rahmen der Druckprozesse möglich ist.



CASALGRANDE  
PADANA  
Pave your way

via Statale 467, n. 73 - 42013 Casalgrande (Re) Italy  
tel + 39 0522 9901 - fax + 39 0522 996121  
info@casalgrandepadana.it - www.casalgrandepadana.com

